 This work is protected by
US copyright laws and is for
instructors' use only.

Instructor's Manual with PowerPoints
to accompany

PROCESS CONTROL INSTRUMENTATION TECHNOLOGY

Eighth Edition

Curtis D. Johnson



Upper Saddle River, New Jersey
Columbus, Ohio

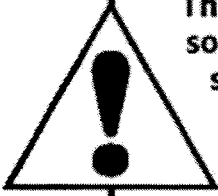

This work is protected by United States copyright laws and is provided solely for the use of instructors in teaching their courses and assessing student learning. Dissemination or sale of any part of this work (including on the World Wide Web) will destroy the integrity of the work and is not permitted. The work and materials from it should never be made available to students except by instructors using the accompanying text in their classes. All recipients of this work are expected to abide by these restrictions and to honor the intended pedagogical purposes and the needs of other instructors who rely on these materials.

Copyright © 2006 by Pearson Education, Inc., Upper Saddle River, New Jersey 07458.

Pearson Prentice Hall. All rights reserved. Printed in the United States of America. This publication is protected by Copyright and permission should be obtained from the publisher prior to any prohibited reproduction, storage in a retrieval system, or transmission in any form or by any means, electronic, mechanical, photocopying, recording, or likewise. For information regarding permission(s), write to: Rights and Permissions Department.

Pearson Prentice Hall™ is a trademark of Pearson Education, Inc.

Pearson® is a registered trademark of Pearson plc

Prentice Hall® is a registered trademark of Pearson Education, Inc.

Instructors of classes using Johnson, *Process Control Instrumentation Technology, Eighth Edition*, may reproduce material from the instructor's manual with PowerPoints for classroom use.

10 9 8 7 6 5 4 3 2 1



ISBN 0-13-119458-5

CHAPTER 1

1.1

The basic strategy of the room air-conditioner can be described as follows:

1. Measure the temperature in a room by means of a "thermostat", which is nothing more than a sensor of temperature. Thus temperature is the controlled variable.

2. The measured temperature is compared to a setpoint in the thermostat. Often this is simply a bimetal strip which closes a contact when the temperature exceeds some limit.

3. If the temperature is too low then the compressor and distribution fan of the air-conditioner are turned on. This causes room air to be circulated through the unit and thereby cooled and exhausted back into the room. Therefore you can see that the manipulated variable is the temperature of the recirculated air.

The system is self-regulating because even without operation of the air-conditioner, the room will adopt some temperature in equilibrium with the outside air, open windows/doors, cooking, etc., etc.

1.2

Driving a car is a servomechanism because the objective is to control the motion of the vehicle rather than to regulate a specific value. Therefore the objective is to cause the vehicle to follow a prescribed path. Of course keeping the speed constant during a trip could be considered process control since the speed is being regulated.

1.3

The refrigerator is a classical example of a process control system. The controlled variable is the temperature of the air in the refrigerator and the controlling variable is the pumping of air across the cooled coils of the evaporator coils. The setpoint is determined by the "coldness" setting of a knob in the unit. The following statements describes the refrigerator.

(a) measurement: A sensor in the refrigerator to measure ambient internal temperature. This may be a gas bulb type where pressure determines the temperature or an electronic type.

(b) setpoint: Determined by a knob setting.

(c) error detector/controller: This will typically be a relay to turn on the compressor/fan driven by gas pressure or an electrical signal. Deadband is provided to prevent excessive cycling.

(d) process: This is of course the refrigerator and all its contents.

(e) final control element: The compressor may be thought of as the final control element although one may argue the evaporator coils and circulation fan do the actual action on the process.

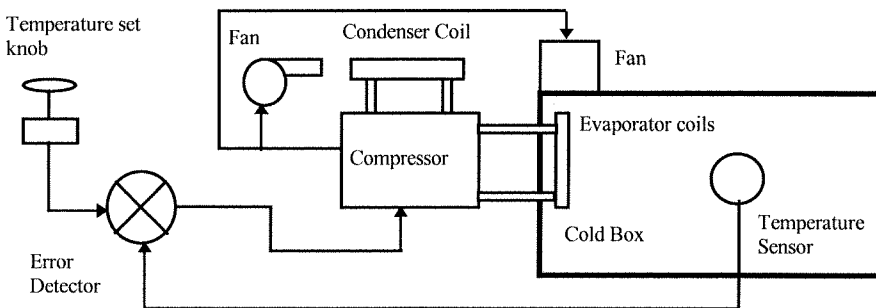

1.4

(a) maximum error = peak error - setpoint = $197\text{ }^{\circ}\text{C} - 175\text{ }^{\circ}\text{C} = 22\text{ }^{\circ}\text{C}$

(b) settling time = time of first excursion beyond $175 \pm 5\text{ }^{\circ}\text{C}$ to the time that range is re-acquired.

$$= 9.8\text{ s} - 1.4\text{ s}$$

$$= 8.4\text{ s}$$

(c) residual error = error remaining after the transient has finished.

$$\approx 1\text{ }^{\circ}\text{C}$$

1.5

The area of the two curves can be approximated by the areas of rectangles as:

The absolute magnitudes of the rectangular areas are summed to give:

(a) Area = 6 units

(b) Area = 9 units

Therefore response (a) has the minimum area.

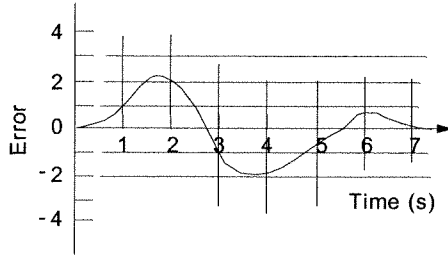

(a)

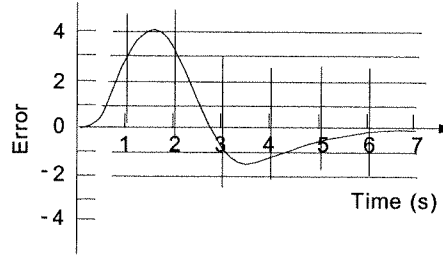

(b)

1.6

Since each peak must be a quarter of the previous the next peak must be given by:

$$a_3 = (1/4)a_2$$

$$a_3 = (1/4)(4.4\%) = 1.1\%$$

1.7

Consider the following analysis:

$$\text{The 1st peak error} = 197.5 - 175 = 22.5.$$

$$\text{One quarter of this is } 5.6 \text{ but the actual peak is } 7.$$

The third peak should be about 1.75 but is 2. The conclusion is that the tuning does not match quarter-amplitude exactly since each peak is higher than that predicted by the criteria.

1.8

Since it is linear we can calculate the current for each m^3/hr of flow rate, as: $(50 \text{ mA})/(300 \text{ m}^3/\text{hr}) = 1/6 \text{ mA per m}^3/\text{hr}$ so, for $225 \text{ m}^3/\text{hr}$, the current will be

$$I = (225 \text{ m}^3/\text{hr})(1/6 \text{ mA}/(\text{m}^3/\text{hr})) \quad I = 37.5 \text{ mA}$$

1.9

$$14_{10} = 1110_2$$

1.10

We can make a table of changes for the 16 states of the 4-bit ADC

Binary	Level	Binary	Level
0000	0	1001	1.35
0001	0.15	1010	1.50
0010	0.30	1011	1.65
0011	0.45	1100	1.80
0100	0.60	1101	1.95
0101	0.75	1110	2.10
0110	0.90	1111	2.25
0111	1.05		
1000	1.20		

So we see that a level of 1.7 m would result in an output of 1011_2 , since the level is greater than 1.65 but not yet 1.8 for the next bit change. If the bits were 1000_2 then the MOST that can be said is that the level is between 1.20 m and 1.35 m. Thus there is an uncertainty of 0.15 m.

1.11

Well, first of all there are $0.15 \text{ V}/^\circ\text{C}$ produced by the measurement, so the output of the measurement is $0.15T \text{ V}$. Second, the differential amplifier will subtract 3 V (the setpoint) and then amplify the result by 10 (ten). Thus the input to the diodes and the relays is:

$$V_D = 10(0.15T - 3)$$

or, solving for T , since that is what we want to find,

$$T = (3 + V_D/10)/0.15$$

If we assume ideal diodes with no forward voltage drop, then the temperatures can be found from the above equation by setting V_D equal to $+1.5 \text{ V}$, $+1.1 \text{ V}$, -1.1 V , and -1.5 V and solving for T in each case.

- +1.5 V: cooler on, $T = (3 + 1.5/10)/.15 = 21 \text{ }^\circ\text{C}$
- +1.1 V: cooler off, $T = (3 + 1.1/10)/.15 = 20.7 \text{ }^\circ\text{C}$
- 1.1 V: heater off, $T = (3 - 1.1/10)/.15 = 19.3 \text{ }^\circ\text{C}$
- 1.5 V: heater on, $T = (3 - 1.5/10)/.15 = 19 \text{ }^\circ\text{C}$

1.12 For Supervisory Control:

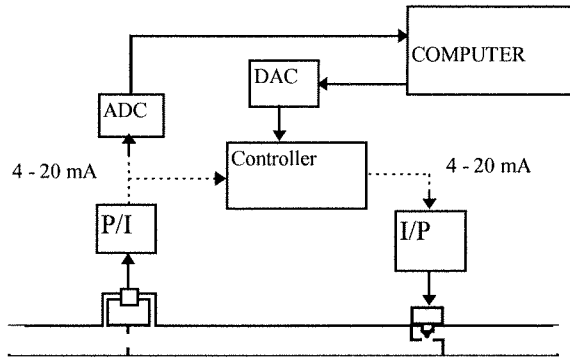

For Computer Control:

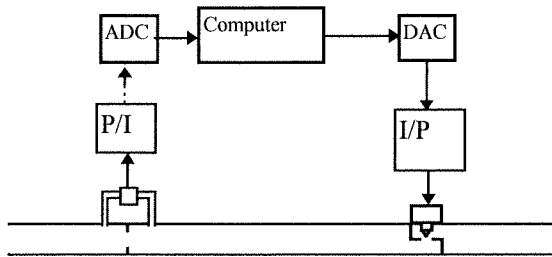

1.13

First of all we need a manual valve on the cold water, a temperature sensor on the mixed hot and cold water and a temperature readout. Then on the hot water side we need a control system to regulate the hot water valve. The system block diagram for analog and digital control is shown in the following diagrams: (a) analog

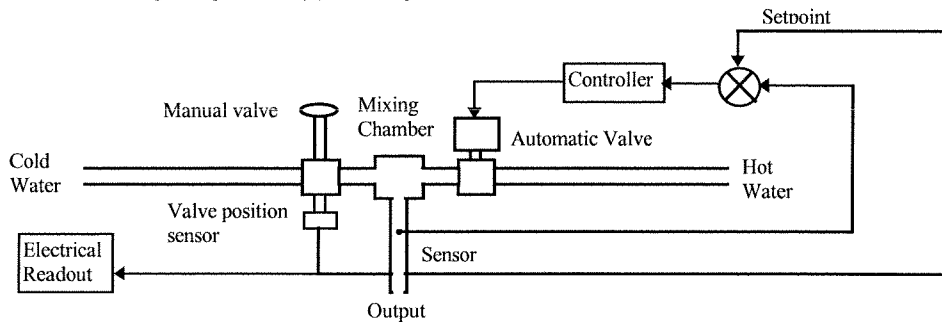

Computer Control:

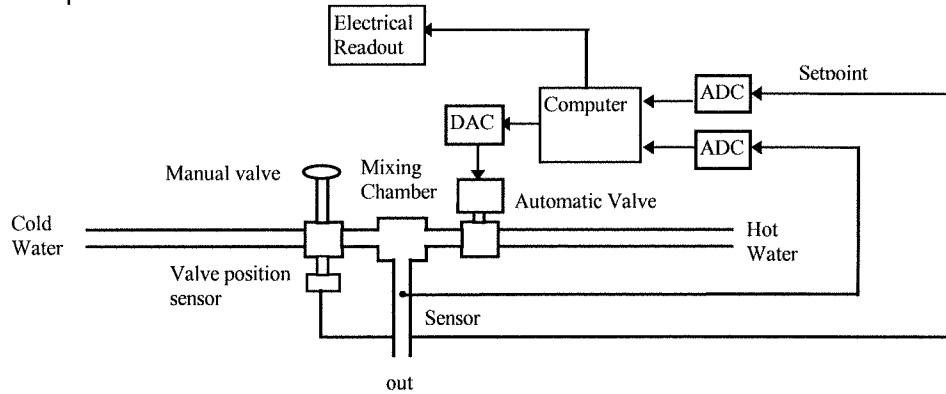

1.14

(For example) I weigh about 170 lb, so this is

$$(170 \text{ lb})(0.454 \text{ kg/lb}) = 77.2 \text{ kg}$$

I am 5 feet 11 inches tall so let's first convert to inches and then multiply by the SI conversion factor

$$(5 \times 12 + 11)(0.0254 \text{ in/m}) = 1.8 \text{ m}$$

1.15

$$\begin{aligned} \rho_{at} &= (14.7 \text{ psi}) / (1.45 \times 10^{-4} \text{ psi/Pa}) \\ &= 101,379 \text{ Pa} \end{aligned}$$

1.16

1 mile = 5280 ft and 1 ft = 0.3048 m

(a) for the acceleration we find,

$$a = 2x/t^2 = (2)(.25 \text{ mile})(5280 \text{ ft/mile}) / (7.2^2) \quad a = 50.93 \text{ ft/s}^2$$

(b) in m/s^2 we have $a = (50.93 \text{ ft/s}^2)(0.3048 \text{ m/ft}) = 15.5 \text{ m/s}^2$

(c) we have velocity, $v = 2ax$ so,

$$v = (2)(15.5 \text{ m/s}^2)(.25 \text{ mile})(5280 \text{ ft/mile})(.3048 \text{ m/ft}) \quad v = 111.7 \text{ m/s}$$

(d) The weight must be converted to mass in kg,

$$m = (2000 \text{ lb})(0.454 \text{ kg/lb}) = 908 \text{ kg}$$

now,

$$\begin{aligned} W &= (908 \text{ kg})(111.7 \text{ m/s})^2 / 2 \\ W &= 5.67 \times 10^6 \text{ kg}\cdot\text{m}^2/\text{s}^2 = 5.67 \times 10^6 \text{ J} \end{aligned}$$

1.17

We can form a linear equation relating level and pressure,

$$p = mL + p_0$$

The slope, m, and intercept can be found from the two conditions,

$$3 \text{ psi} = (5.5 \text{ m})m + p_0$$

$$15 \text{ psi} = (8.6 \text{ m})m + p_0$$

subtracting the 1st from the second gives,

$$m = (15 - 3) / (8.6 - 5.5) \text{ psi/m} = 3.87 \text{ psi/m}$$

Then the intercept can be found as $p_0 = 3 \text{ psi} - (5.5 \text{ m})(3.87 \text{ psi/m}) = -18.29$

Thus the relation is,

$$p = 3.87L - 18.29$$

Now, a level of 7.2 m gives, $p = 3.8(7.2) - 18.29 = 9.57 \text{ psi}$

and a pressure of 4.7 means, $4.7 = 3.87L - 18.29$. Solving for L gives $L = 5.94 \text{ m}$.

1.18

For a current of 12 mA we have a flow given by,

$$Q = 45[12 \text{ mA} - 2 \text{ mA}]^{1/2} = 142.3 \text{ gal/min}$$

If the flow is 162 gal/min we can form an equation,

$$162 = 45[I - 2 \text{ mA}]^{1/2}$$

solving for I we find,

$$I = (162/45)^2 + 2 = 14.96 \text{ mA}$$

1.19

$\pm 0.5\%$ FS for 0 to 1500 Ω means $(\pm 0.005)(1500) = \pm 7.5 \Omega$. Thus a measurement of 397 Ω actually means $397 \pm 7.5 \Omega$ or from 389.5 Ω to 404.5 Ω .

1.20

Well, 0.5 mV/ $^{\circ}\text{C}$ with a $\pm 1\%$ accuracy means the transfer function could be $0.5 \pm 0.005 \text{ mV}/^{\circ}\text{C}$ or 0.495 to 0.505 mV/ $^{\circ}\text{C}$. If the temperature were 60 $^{\circ}\text{C}$ the output would be in the range, $(0.495 \text{ mV}/^{\circ}\text{C})(60^{\circ}\text{C}) = 29.7 \text{ mV}$ to $(0.505 \text{ mV}/^{\circ}\text{C})(60^{\circ}\text{C}) = 30.3 \text{ mV}$ or $30 \pm 0.3 \text{ mV}$. Which is, of course, $\pm 1\%$.

1.21

We can express the three uncertainties in the fractional form as:

$$0.5 \pm 1\% \text{ mV}/^{\circ}\text{C} = 0.5(1 \pm 0.005/0.5) \text{ mV}/^{\circ}\text{C} \quad 15 \pm 0.25 \text{ gain} = 15(1 \pm .25/15) \text{ gain}$$

$$V \pm 1\% \text{ FS volts} = V(1 \pm 0.03/2) \text{ volts}$$

The worst case uncertainty would come from simply summing the three above:

$$\begin{aligned} \text{Worst Case} &= \pm (0.005/0.5 + 0.25/15 + 0.03/2) \\ &= \pm 4.2\% \end{aligned}$$

The rms computation is probably a more realistic value. It is found as:

$$\text{RMS} = [(0.005/0.5)^2 + (0.25/15)^2 + (0.03/2)^2]^{1/2} = \pm 2.5\%$$

1.22

Using the nominal values means that the transfer function from temperature to voltage is given by:

$$V = (0.5 \text{ mV}/^{\circ}\text{C})(15)T = 0.0075T$$

Now, the maximum measurable voltage is two, so the temperature is found from:

$$\begin{aligned} T_{\text{max}} &= V_{\text{max}}/0.0075 = 2.0/0.0075 \\ &= 266.7^{\circ}\text{C} \end{aligned}$$

1.23

This is a linear transducer so it is represented by the equation of a straight line with a zero intercept, so $V = KT$ with $K = 44.5 \text{ mV}/^{\circ}\text{C}$,

$$V = 0.0445T$$

If $V = 8.86$ volts then, $T = V/K = 8.86/0.0445 = 199.1011236^{\circ}\text{C}$

but we have only three significant figures, so the temperature is reported as,

$$T = 199^{\circ}\text{C}$$

1.24

This is a linear transformation, so we expect the equation of a straight line to relate the two variables,

$$P = KL + P_0$$

We have been given two facts about the variables so we can set up two equations in two unknowns, K and P_0 ,

$$3 \text{ psi} = K(4.50 \text{ ft}) + P_0$$

$$15 \text{ psi} = K(10.6 \text{ ft}) + P_0$$

subtracting the first equation from the second gives, $12 \text{ psi} = K(6.10 \text{ ft})$, so to three significant figures, $K = 1.97 \text{ psi/ft}$

Now, this is used in the first equation to find,

$$P_0 = 3 \text{ psi} - (1.97 \text{ psi/ft})(4.50 \text{ ft})$$

$$P_0 = -5.87 \text{ psi}$$

Thus the equation is,

$$P = 1.97L - 5.87$$

A level of 9.2 ft gives,

$$P = (1.97)(9.2) - 5.87$$

$$P = 12.3 \text{ psi}$$

1.25

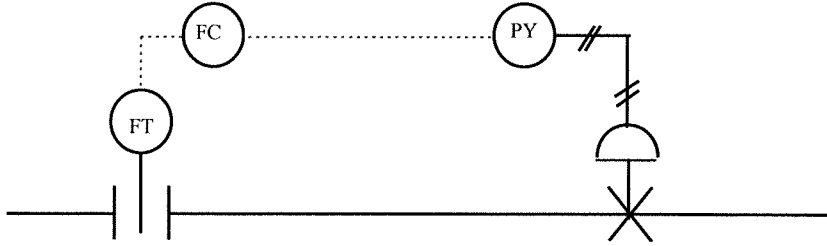

1.26

We do not have to use the transfer function at all since the relation between voltage and temperature is linear. Using the equation for first-order time response,

$$T = T_i + (T_f - T_i)(1 - e^{-t/\tau})$$

$$T = 22^\circ\text{C} + (50^\circ\text{C} - 22^\circ\text{C})(1 - e^{-t/3.3\text{ s}}) \quad T = 22 + 28(1 - e^{-t/3.3})^\circ\text{C}$$

$$t = 0.5 \text{ s}; T = 22 + 28(1 - e^{-0.5/3.3}) = 22 + 28(1 - 0.8594) \quad T = 25.9^\circ\text{C}$$

$$t = 2.0 \text{ s}; T = 22 + 28(1 - e^{-2/3.3}) = 34.7^\circ\text{C}$$

$$t = 3.3 \text{ s}; T = 22 + 28(1 - e^{-3.3/3.3}) = 39.7^\circ\text{C}$$

$$t = 9.0 \text{ s}; T = 22 + 28(1 - e^{-9/3.3}) = 48.2^\circ\text{C}$$

1.27

Using the first-order time response equation, we know everything except the time constant,

$$52 = 44 + (70 - 44)(1 - e^{-4.5/\tau})$$

$$8 = 26(1 - e^{-4.5/\tau})$$

$$e^{-4.5/\tau} = 1 - 8/26 = 0.6923$$

taking natural logarithms of both sides,

$$-4.5/\tau = \ln(0.6923) = -0.3677$$

$$\tau = 12.2 \text{ s}$$

1.28

This is a first-order time response problem for light intensity. We have the relation,

$$I = I_i + (I_f - I_i)(1 - e^{-t/\tau})$$

When the indicated value is 80% it means that 80% of the total change will have occurred, i.e.,

$$(I - I_i) = 0.8(I_f - I_i)$$

Thus the equation becomes,

$$0.8 = 1 - e^{-t/0.035 \text{ s}}, \text{ or}$$

$$0.2 = e^{-t/0.035}$$

Taking natural logarithms of both sides gives,

$$-1.609 = -t/0.035, \text{ so that,}$$

$$t = 56 \text{ ms}$$

1.29

Ok, the question is how does the voltage vary with time and then when does it reach 4.00 volts?

Well, the first order time constant equation, for the voltage, will tell us.

First we need the initial and final values of voltage, which come from the static transfer function,

$$V_i = (20 \text{ mV/kPa})(100 \text{ kPa}) = 2.0 \text{ volts}$$

$$V_f = (20 \text{ mV/kPa})(400 \text{ kPa}) = 8.0 \text{ volts}$$

Now, the time at which the voltage reaches 4.0 volts is given by,

$$4.0 = 2.0 + (8.0 - 2.0)(1 - e^{-t/4.9})$$

$$2.0 = 6.0(1 - e^{-t/4.9})$$

$$e^{-t/4.9} = 0.6666, \text{ taking the natural log of both sides gives,}$$

$$-t/4.9 = \log_e(0.6666) = -0.4054$$

so

$$t = 1.99 \text{ s}$$

1.30

The sensor response is linear but the signal conditioning converts this nonlinearly to a voltage. Thus there are three steps in converting a sudden change in pressure to a voltage. First the transfer function conversion of pressure to resistance, second the first order time response of the sensor and third the conversion of resistance to voltage. The pressure itself has only two values, initially 40 psi and finally (and instantaneously after $t = 0$) 150 psi. The initial and final resistance's are:

$$R_i = 0.15(40) + 2.5 \text{ k}\Omega = 8.5 \text{ k}\Omega$$

$$R_f = 0.15(150) + 2.5 \text{ k}\Omega = 25 \text{ k}\Omega$$

(a) at $t = 0.5$ seconds we find the resistance as,

$$R(0.5) = 8.5 + (25 - 8.5)[1 - e^{-0.5/0.35}] \text{ k}\Omega = 21 \text{ k}\Omega$$

so the output voltage is,

$$V(0.5) = (10)(21 \text{ k}\Omega)/(21 \text{ k}\Omega + 10 \text{ k}\Omega) = 6.77 \text{ V}$$

The indicated pressure is found from the sensor transfer function,

$$21 \text{ k}\Omega = 0.15p(\text{indicated}) + 2.5 \text{ k}\Omega$$

$$p(\text{indicated}) = 123 \text{ psi (but of course the pressure is actually 150 psi)}$$

(b) We must work back from the voltage. First we find the resistance,

$$R(t) = (10 \text{ k}\Omega)(5.0 \text{ V})/(10 \text{ V} - 5.0 \text{ V}) = 10 \text{ k}\Omega$$

Now we use the first order time response equation to find the time at which this resistance occurs,

$$10 \text{ k}\Omega = 8.5 + 16.5[1 - e^{-t/0.35}] \text{ k}\Omega$$

solving,

$$e^{-t/0.35} = 0.91$$

$$-t/0.35 = \ln(0.91) = -0.095$$

$$t = 0.033 \text{ s}$$

Note that we could not find the initial and final voltages and apply the first order time response equation directly to the voltage because of the nonlinear relation between resistance and voltage.

1.31

The initial and final sensor voltages are,

$$V_i = 0.06(25 - 20) = 0.3 \text{ V and } V_f = 0.06(100 - 20) = 4.8 \text{ V}$$

The first order time response equation is given by,

$$V(t) = 0.3 + (4.8 - 0.3)[1 - e^{-t/\tau}] = 0.3 + 4.5[1 - e^{-t/\tau}]$$

Solving for the time constant gives,

$$\tau = -t/[\ln(4.8 - V(t)) - \ln(4.5)]$$

Now the values of t can be computed for each given time and voltage,

t	$V(t)$	τ
0	0.3	0 (not a valid data point)
0.1	1.8	0.247
0.2	2.8	0.247
0.3	3.4	0.257
0.4	3.9	0.249
0.5	4.2	0.248

So the average for the time constant is $t_{\text{ave}} = 0.25 \text{ s}$

1.32

Hey, from Ohm's Law, $I = 4.7 \text{ V}/1.5 \text{ k}\Omega = 3.13333333 \text{ mA}$ as a "designed" or calculated value.

Now, if we measure 4.7 V and 1500 Ω then we report the current as, $I = 3.1 \text{ mA}$, because the 4.7 V has only two significant figures.

1.33

There are 17 values, if x_i represents the values of flow rate then the mean is found from,

$$\langle x \rangle = \sum x_i / N = 174.8/17$$

$$\langle x \rangle = 10.3 \text{ gal/min} \quad \text{The standard deviation is found from,}$$

$$\sigma = \sqrt{\sum (x_i - \langle x \rangle)^2 / (N-1)}$$

$$\sigma = 26.79/16$$

$$\sigma = 1.29 \text{ gal/min}$$

1.34

Initially the pressure is exactly 20 kPa and finally the pressure is exactly 100 kPa. The problem is that the static transfer function is uncertain by 5%, so the output voltage of the sensor will be uncertain by 5% also.

(a) Nominally the initial voltage will be $V_i = (45 \text{ mV/kPa})(20 \text{ kPa}) = 0.9 \text{ volts}$ and for the final voltage, $V_f = (45 \text{ mV/kPa})(100 \text{ kPa}) = 4.5 \text{ volts}$.

Because of the uncertainty in the transfer function the actual output voltages expected will be,

$$V_i = 0.9 \pm 5\% = 0.9 \pm 0.045 \text{ or } 0.855 \text{ to } 0.945 \text{ volts}$$

and

$$V_f = 4.5 \pm 5\% = 4.5 \pm 0.225 \text{ or } 4.275 \text{ to } 4.725 \text{ volts}$$

(b) After 2 seconds the voltage output will depend upon the first order time response, the uncertainties in initial and final voltages and the uncertainties in the time constant. The voltage uncertainties are all 5% while the time constant is $4 \pm 10\% = 4 \pm .4 \text{ seconds}$. Noting that it is only the static transfer function which is uncertain and not the pressure, we can write,

$$V(t) = V_i + (V_f - V_i)(1 - e^{-t/\tau})$$

$$V(t) = (45 \pm 5\% \text{ mV/kPa})[p_i + (p_f - p_i)(1 - e^{-t/\tau})]$$

$$V(2) = (45 \pm 5\%)[20 + (100 - 20)(1 - e^{2/(4 \pm .4)})]$$

Taking the time constant to be 4.4 s gives,

$$V_+(2) = (45 \pm 5\%)[20 + 80(1 - e^{-0.454})]$$

$$= (45 \pm 5\%)49.2 = 2.214 \pm 5\% = 2.214 \pm 0.111 \text{ volts}$$

so we expect the output to be 2.103 to 2.325 volts.

Taking the time constant to be 3.6 s gives,

$$V_-(2) = (45 \pm 5\%)[20 + 80(1 - e^{-0.555})]$$

$$= (45 \pm 5\%)54.1 = 2.435 \pm 5\% = 2.435 \pm 0.122 \text{ volts}$$

so we expect the output to be 2.313 to 2.557 volts. FINALLY the answer is that the output voltage for this measurement will be expected to lie in the range, 2.103 to 2.557 volts, which is 2.330 ± 0.227 or $2.330 \pm 9.7\%$.

SUPPLEMENTARY PROBLEMS

S1.1

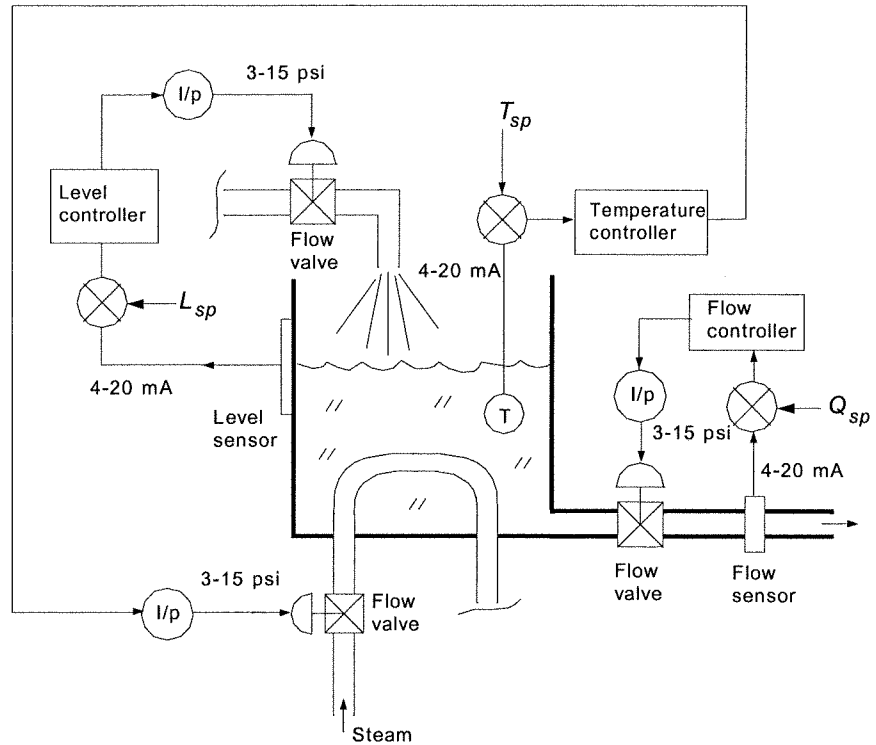

S1.2

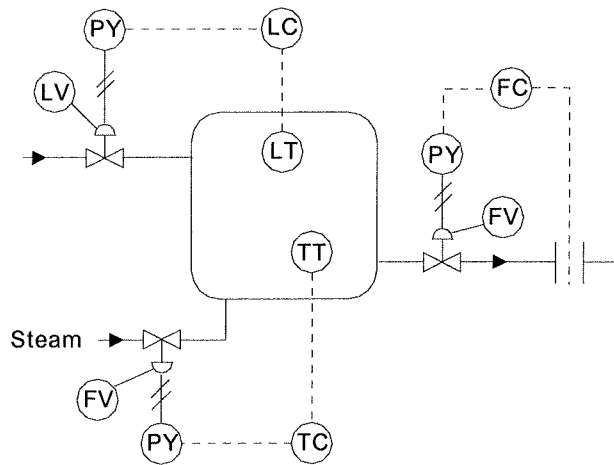

S1.3

Temperature is self-regulating because if the steam valve sticks at some setting the temperature will rise until equilibrium between heat flow out matches steam in, which will be some value less than the steam temperature. Flow out is self-regulating in the sense that for a stuck valve setting the flow simply maintains a fixed value. Level is not self-regulating because if the in-flow valve is stuck at some value which does not exactly match the out-flow the tank must empty or overflow.

S1.4

If the output flow valve was stuck closed then the level control system would simply shut off the input flow valve as the level rose and the level error became large. Therefore the tank would not overflow because of the level control system.

S1.5

Assume the tank is empty. Then sensor output is low and the relay is open so the output valve is closed. The level, h , will rise until the voltage to the amplifier reaches 6.0 volts. Then the relay closes which opens the valve and the level begins to drop (since outflow exceeds inflow). When the level drops to a point where the relay voltage becomes 4.8 V or less, the relay will open and the valve will close. This cycle then just repeats.

(a) To open the valve at 1.5 meters means the relay voltage must reach 6.0 V at that level,

$$6.0 = K(0.8h + 0.4) = K(0.8 \cdot 1.5 + 0.4) = 1.6K$$

$$\text{So, } K = 6/1.6 = 3.75$$

(b) The valve closes when the relay voltage drops to 4.8 V,

$$4.8 = 3.75(0.8h + 0.4)$$

$$h = (4.8/3.75 - 0.4)/0.8 = 1.1 \text{ meters}$$

(c) When the valve is closed the net input flow rate is,

$$Q_{in} = Q_1 + Q_2 = (5 + 2) \text{ m}^3/\text{min} = 7 \text{ m}^3/\text{min}$$

The volume of liquid in the tank is that of a cylinder of radius $r = 2$ m and height, h . The volume is given by the equation, $V = \pi r^2 h = 4\pi h$. The relationship between input flow rate, volume and time is given by,

$$V(t) = Q_{in}t.$$

Now we can calculate how long it takes from the height to rise from 1.1 to 1.5 meters,

$$t_{rise} = \Delta V(t)/Q_{in} = 4\pi(1.5 - 1.1) \text{ m}^3 / (7 \text{ m}^3/\text{min}) = 0.72 \text{ min}$$

When the valve opens there is an outflow of $9 \text{ m}^3/\text{min}$ and the inflow remains at $7 \text{ m}^3/\text{min}$, so the net is an outflow of $2 \text{ m}^3/\text{min}$. Therefore the time for level to drop from 1.5 m to 1.1 meters is given by,

$$t_{drop} = \Delta V(t)/Q_{out} = 4\pi(1.5 - 1.1) \text{ m}^3 / (2 \text{ m}^3/\text{min}) = 2.51 \text{ min}$$

So, the total period is 3.23 min.

S1.6

Since the pressure varies from 0 to 100 psi and the voltage is given by $0.5\sqrt{p}$ the voltage must vary from 0 to 5 volts. This voltage variation must produce a current that varies from 4 to 20 mA.

(a) The relationship between voltage and current will be given by, $I = mV + I_0$. From the given information we form:

$$4 \text{ mA} = m(0) + I_0$$

$$20 \text{ mA} = m(5) + I_0$$

From the first equation we find $I_0 = 4$ mA. The second equation gives, $m = (20 - 4) \text{ mA} / 5 \text{ V} = 3.2 \text{ mA/V}$

The transfer function equation is,

$$I = 3.2V + 4 \text{ mA}$$

(b) When the current is 20 mA the pressure is 100 psi. When the current is 19 mA the sensor output voltage is given by $V = (19 - 4)/3.2 = 4.6875 \text{ V}$. Therefore the pressure is found as

$$p = (V/0.5)^2 = (4.6875/0.5)^2 = 87.89 \text{ psi.}$$

So the pressure change is given by $\Delta p = 100 - 87.89 = 12.11 \text{ psi}$

(c) When the current is 4 mA the pressure must be 0 psi. The voltage at 5 mA is given by,

$$V = (5 - 4)/3.2 = 0.3125 \text{ V so the pressure is } p = (0.3125/0.5)^2 = 0.39 \text{ psi and therefore the}$$

pressure change is $\Delta p = 0.39 \text{ psi}$. The reason this is not the same as the previous case is because the output voltage of the sensor varies nonlinearly with the pressure. At low pressure the voltage (and also current) change very slowly with pressure while at high pressure the voltage (and current) change very fast with pressure.

(d) The following graph shows the nonlinear variation of the current versus pressure.

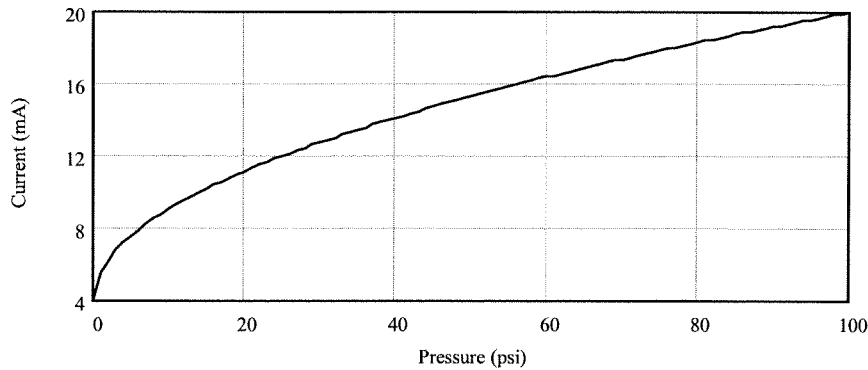

S1.7

(a) Since this is a first order time response sensor and the input is essentially an instantaneous change, the time response equation of Equation (1.7) will be very accurate. Therefore one need only measure the response at $t = 1$ second and calculate the "final value" using that equation. This must be done with voltage however and then pressure determined from the transfer function of the sensor.

(b) Given $V_p = 1.45$ volts at $t = 1$ second we first note that $V_i = 0.05(500)/2 = 1.12$ V. Then we have

$$V(t) = V_i + (V_f - V_i)[1 - e^{-t/\tau}]$$

$$1.45 = 1.12 + (V_f - 1.12)[1 - e^{-1/2}]$$

$$V_f = 1.12 + \frac{1.45 - 1.12}{1 - e^{-0.5}} = 1.959 \text{ V}$$

now use the transfer function to find the pressure, $p_{max} = (V_p/0.05)^2 - 500 = (1.959/0.05)^2 - 500 = 1035$ psi.

(c) For $p_{max} = 2500$ we first find the final voltage, $V_f = 0.05(2500+500).5 = 2.739$ V. Now we simply use Equation (1.7),

$$V(1) = 1.12 + (2.739 - 1.12)[1 - e^{-0.5}] = 1.76 \text{ V}$$

(d) First we find the final voltage from the measurement at one second,

$$V_f = 1.12 + \frac{V(1) - 1.12}{1 - e^{-0.5}}$$

and then the pressure from the transfer function of the sensor,

$$p_{max} = \left(\frac{V_f}{0.05} \right)^2 - 500$$

S1.8

(a) The elements of the system in Figure 1.35 have the following description:

- YIC 110 is a PLC which operates an open/closed valve in the B line. The valve is actuated by an electrical signal.
- FT 103 is an orifice plate flow sensor and transmitter with a pneumatic output that feeds a square root block having an electrical output.
- FC 104 is a flow controller which has a setpoint provided by FT 103, an electrical output signal to flow valve PY 104 and takes its input signal from flow sensor FT 104.
- PY 104 is an I/P converter which converts the electrical signal from the controller into a pneumatic signal for the flow valve.
- FT 104 is an orifice plate flow sensor with a pneumatic output connected to a square root detector which has an electrical signal output.
- PT 101 is a pressure sensor/transmitter with an electrical output.
- PC 101 is a controller for pressure which takes its setpoint input as a digital signal from a computer PC 101 and outputs an electrical signal to a control valve motor, M 101.
- M 101 is an electrical motor which actuates the valve for product C.
- PC 101 is a computer which provides the setpoint of the pressure control system.
- YIC 112 is a PLC which controls a vent valve

- TS 102 is a temperature sensor feeding an electrical signal to PLC YIC 102

(b) There are two control loops. Loop 101 is a pressure control valve. Pressure is measured by PT 101 and provided as input to controller PC 101. This unit then provides feedback by controlling the opening of the C valve via a motor, M 101. Loops 103 and 104 constitute cascaded control loops. The output of loop 103 is the setpoint of loop 104. Loop 104 controls flow of reactant A into the reaction chamber. The flow rate of B provides the setpoint of the A flow control loop. This system assures that both loops provide the same flow rate.

(c) PLC YIC 110 provides an overall system shut down by opening or closing the flow rate of reactant B into the reaction chamber. PLC YIC 112 opens a vent valve for the reaction chamber. PLC YIC 102 is an input of a temperature limit in the reaction chamber.

CHAPTER 2

2.1

We need to solve for the voltage dropped across the load, which is labeled V_y , in Figure 2.2. This can be found from Ohm's Law if the current is known by subtracting the voltage dropped across R_x from the source, V_x ,

$$V_y = V_x - IR_x$$

Let the current through the loop formed by V_x , R_x and R_L in Figure 2.2 be described by I and assume a clockwise direction. This current is found from Ohm's Law as the voltage divided by the total resistance,

$$I = \frac{V_x}{R_x + R_y}$$

Substituting in the equation for V_y given above, provides the required result,

$$V_y = V_x \left(1 - \frac{R_x}{R_x + R_y} \right)$$

2.2

We can find the circuit output voltage amplitude by using the impedance. Thus the output is simply a divider loaded voltage:

$$V_{out} = \frac{V_S Z_L}{Z_L + Z_S} \quad \text{where } V_S = 5\angle 0^\circ, Z_L = -j/\omega C = j/(2\pi fC)$$

so, $Z_L = [2\pi(200 \text{ Hz})(0.22 \mu\text{F})]^{-1} = -3617j \Omega$ and $Z_S = 2000 + 600j$. Thus the output voltage is,

$$V_{out} = \frac{(5\angle 0^\circ)(0 - 3617j)}{(2000 + 600j - 3617j)} = 4.2 - 2.8j$$

so the amplitude is $|V_{out}| = 5.04 \text{ V}$

2.3

The divider output voltage is found from;

$$V_D = \frac{V_S R_2}{R_1 + R_2} = \frac{(10)(500)}{R_1 + 500}$$

(a) For $R_1 = 520 \Omega$, $V_D = 4.90 \text{ V}$ and for $R_1 = 2500 \Omega$, $V_D = 1.67 \text{ V}$.

(b) Sensor dissipation is given by $P_S = V_S^2/R_S$, where $V_S = 10 - V_D$ therefore, for $R_1 = 520 \Omega$, $P_S = 50.0 \text{ mW}$ and for $R_1 = 2500 \Omega$, $P_S = 27.8 \text{ mW}$

2.4

The solution to Example 2.2 can be expressed using Equation (2.2) as,

$$V_D = \frac{5R_2}{10000 + R_2}$$

A plot of this function for R_2 varying between $4 \text{ k}\Omega$ and $12 \text{ k}\Omega$ shows the result:

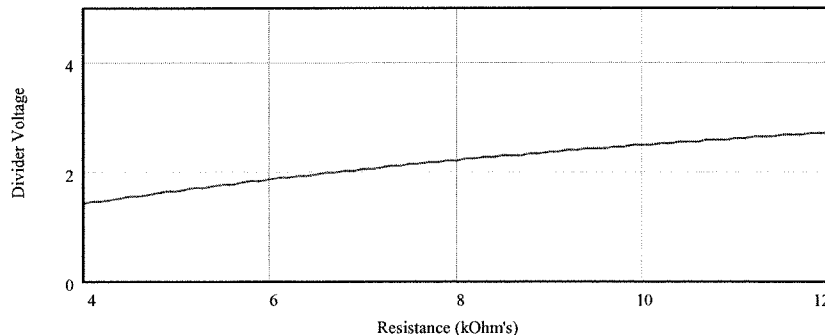

Clearly this is nonlinear and the voltage increases with increasing resistance.

For Problem 2.3 a plot of the divider voltage give above is,

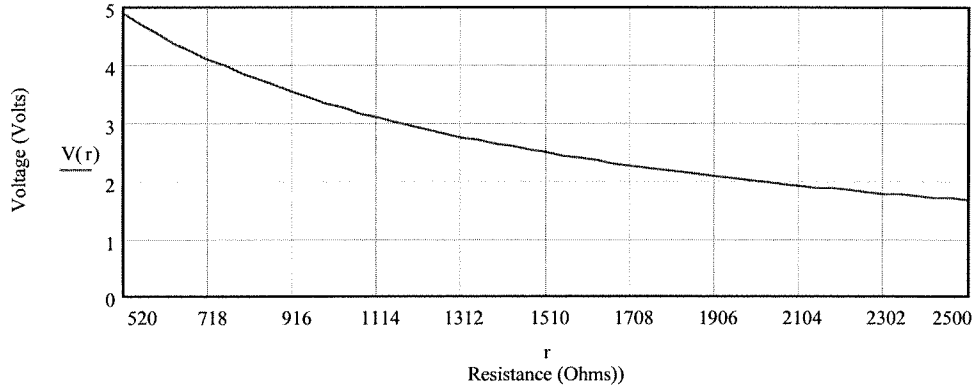

In this case the plot is again nonlinear but the voltage decreases with increasing resistance.

2.5

We put the right side of Equation (2.6) over a common denominator by multiplying both terms by the ratio of the resistance sums,

$$\Delta V = \frac{VR_3}{R_1 + R_3} \frac{R_2 + R_4}{R_2 + R_4} - \frac{VR_4}{R_2 + R_4} \frac{R_1 + R_3}{R_1 + R_3} = \frac{V[R_3(R_2 + R_4) - R_4(R_1 + R_3)]}{(R_1 + R_3)(R_2 + R_4)}$$

Now the expression in the brackets of the numerator is multiplied out and the product R_3R_4 cancels out, leaving the desired result,

$$\Delta V = V \frac{R_3R_2 - R_1R_4}{(R_1 + R_3)(R_2 + R_4)}$$

2.6

The Thevenin resistance between a and b in the bridge of Figure 2.5 is found by replacing the source by its internal resistance, which is assumed to be zero. Then the circuit can be redrawn as,

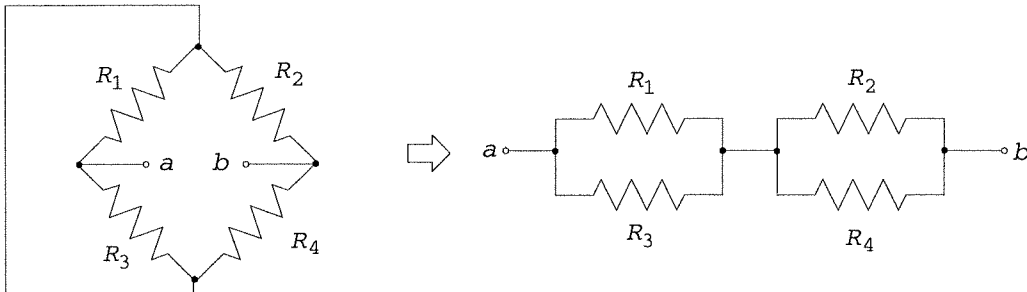

In this case you can see that we have the parallel combination of R_1 and R_3 in series with the parallel combination of R_2 and R_4 . Thus by the parallel rule for two resistors we have,

$$R_{Th} = \frac{R_1R_3}{R_1 + R_3} + \frac{R_2R_4}{R_2 + R_4}$$

2.7

From the null condition of Equation (2.8) we solve for $R_4 = R_3R_2/R_1$, so

$$R_4 = (448 \Omega)(1414 \Omega)/(227 \Omega) = 2791 \Omega$$

2.8

(a) The value of R_3 to null the bridge is found by solving Equation (2.8) for this resistor,

$$R_3 = R_1R_4/R_2 = (100 \Omega)(50 \Omega)/(100 \Omega) = 50 \Omega$$

(b) The detector resolution needed to resolve a resistance change of 0.1Ω is found from Equation (2.6) or (2.7) when R_4 has changed to 50.1Ω (or 49.9Ω),

$$\Delta V = \frac{(10V)(50\Omega)}{(50\Omega + 100\Omega)} - \frac{(10V)(50.1\Omega)}{(50.1\Omega + 100\Omega)} = -4.44\text{mV}$$

If 49.9Ω were used the result would be $\Delta V = +4.45 \text{ mV}$, where the difference is due to the nonlinearity.

2.9

A diagram will help you understand this problem. The circuit is,

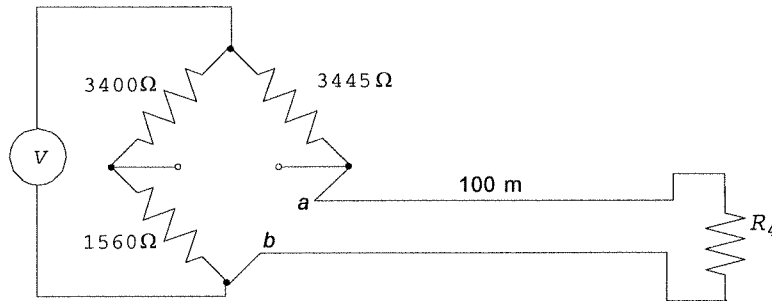

If you use the null equation to find R_4 , it will give the resistance from a to b in the schematic, which includes the two 100 m lead resistances. Thus these must be subtracted to find the actual sensor resistance.

$$R_{ab} = (3445 \Omega)(1560 \Omega)/(3400 \Omega) = 1580.6 \Omega$$

but the lead resistance is,

$$R_{lead} = 2(100 \text{ m})(0.3048 \text{ m/ft})(0.45 \Omega/\text{ft}) = 295.3 \Omega$$

So the actual sensor resistance is,

$$R_4 = 1580.6 \Omega - 295.3 \Omega = 1285.3 \Omega$$

2.10

(a) The bridge null equation is the same for voltage or current detection. Thus, from Equation (2.8) we find, $R_2 = R_1 R_4 / R_3 = (250 \Omega)(340 \Omega) / (500 \Omega) = 170 \Omega$

(b) If $R_2 = 190 \Omega$ the bridge is not nulled (because null occurs for 170Ω). To find the resulting offnull current we use Equation (2.11) along with Equations (2.9) and (2.10),

$$R_{Th} = \frac{(250)(500)}{250 + 500} + \frac{(190)(340)}{190 + 340} = 288.6 \Omega$$

$$V_{Th} = (1.5) \left[\frac{500}{500 + 250} - \frac{340}{340 + 190} \right] = 0.0378 \text{ V}$$

Thus the current is $I_G = \frac{0.0378}{288.6 + 150} = 86.2 \mu\text{A}$

2.11

(a) The value of R_3 to null the bridge with no current is just the null equation for the current balance bridge, Equation (2.8) except that R_4 is now $R_4 + R_5$. Thus,

$$R_3 = R_1(R_4 + R_5)/R_2 = (1 \text{ k}\Omega)(590 \Omega + 10 \Omega)/(1 \text{ k}\Omega) = 600 \Omega$$

(b) If the current is 0.25 mA we must use Equation (2.15) at null to find the value of R_3 .

$$0 = 10 \left[\frac{R_3}{1000 + R_3} - \frac{590 + 10}{1000 + 590 + 10} \right] - (0.00025)(10)$$

Solving this equation for R_3 gives, $R_3 = 600.6 \Omega$

2.12

The value of potential can be found from Equation (2.17),

$$V_x + \frac{10(10 \text{ k}\Omega)}{(10 \text{ k}\Omega + 10 \text{ k}\Omega)} - \frac{10(9.73 \text{ k}\Omega)}{10 \text{ k}\Omega + 9.73 \text{ k}\Omega} = 0 \quad \text{or,} \quad V_x + 5.00 - 4.93 = 0$$

So, $V_x = -68.4 \text{ mV}$ and the negative means that the unknown voltage subtracts from the five volts at point a so that the unknown source positive is connected to a with respect to c in Figure (2.9).

2.13

For the ac bridge we have a null condition of $Z_1 Z_4 = Z_2 Z_3$. For the capacitor the impedance is given by $Z = 1/j\omega C$, but since the j and ω appear in all terms they cancel leaving the null condition given by, $C_1 C_4 = C_2 C_3$. Therefore we can solve for C4 easily,

$$C_4 = C_2 C_3 / C_1 = (0.31)(0.27)/(0.4) \mu\text{F} = 0.21 \mu\text{F}$$

2.14

(a) The impedences for null are $Z_1 = 1000$

$$Z_2 = 2000$$

$$Z_3 = 100 + 0.25\omega j$$

$$Z_4 = R_4 + L_4 \omega j$$

The null equaiton becomes, $1000(R_4 + j\omega L_4) = 2000(100 + 0.25\omega j)$

Equating real and imaginary parts,

$$1000R_4 = 200000 \quad \text{or} \quad R_4 = 200 \Omega \quad 1000\omega L_4 = 500\omega \quad \text{or} \quad L_4 = 0.5 \text{ H}$$

(b) If L4 changes to 0.51 H there will be an offnull voltage given by Equation (2.20).

For a frequency of 1 kHz the impedences are:

$$Z_1 = 1000$$

$$Z_2 = 2000$$

$$Z_3 = 100 + 0.25(2)(\pi)(1000)j = 100 + 1571j$$

$$Z_4 = 200 + 0.51(2)(\pi)(1000)j = 200 + 3204j$$

Thus the offnull voltage is given by,

$$\Delta E = 5 \left[\frac{2000(100 + 1571j) - (1000)(200 + 3204j)}{(1100 + 1571j)(2200 + 3204j)} \right] = 5 \frac{62j}{-2614 + 6980j}$$

which can be reduced to $\Delta E = 38.9 - 14.6j$ where the real part is the in-phase part and the -14.6 is the quadrature part.

2.15

A low pass to attenuate 0.5 Mhz by 97% means that there is only 3% left. Thus we find the critical frequency which gives ratio of output to input voltage of 0.03 when the frequency is 0.5 mHz.

Equation (2.23) provides the required relationship,

$$0.03 = \frac{1}{\left[1 + \left(\frac{f}{f_c} \right)^2 \right]^{1/2}} = \frac{1}{\left[1 + \left(\frac{5 \times 10^5}{f_c} \right)^2 \right]^{1/2}}$$

The solution is $f_c = 15 \text{ kHz}$. To find the values of resistor and capacitor we note that the critical frequency is given by, $f_c = 1/(2\pi RC)$. Thus $RC = 1.06 \times 10^{-5}$. Any combination of R and C that give this product will work but we must pick practical values. Let's try $C = 0.01 \mu\text{F}$, then we will need $R = 1.06 \text{ k}\Omega$, which seems reasonable. The attenuation of a 400 Hz signal will be found from the above equation with $f = 400 \text{ Hz}$ and $f_c = 15 \text{ kHz}$,

$$\left| \frac{V_{out}}{V_{in}} \right| = \frac{1}{\left[1 + \left(\frac{400}{15000} \right)^2 \right]^{1/2}} = 0.9996$$

so the output is only down by 0.04%.

2.16

The attenuation is simply found from Equation (2.23)

$$\left| \frac{V_{out}}{V_{in}} \right| = \frac{1}{\left[1 + \left(\frac{1000}{3500} \right)^2 \right]^{1/2}} = 0.96$$

so the attenuation is $1 - 0.96 = 0.04$

2.17

We find the critical frequency for which a 120 Hz signal has an output to input voltage ratio of 0.01,

$$\left| \frac{V_{out}}{V_{in}} \right| = \frac{(f / f_c)}{\left[1 + (f / f_c)^2 \right]^{1/2}} \quad \text{so} \quad 0.01 = \frac{(120 / f_c)}{\left[1 + (120 / f_c)^2 \right]^{1/2}}$$

From this equation we find $f_c = 12$ kHz. If we pick $C = 0.01 \mu\text{F}$ then $R = 1.33$ k Ω . The attenuation of a 30 kHz signal is,

$$\left| \frac{V_{out}}{V_{in}} \right| = \frac{(30 / 12)}{\left[1 + (30 / 12)^2 \right]^{1/2}} = 0.93 \quad \text{so the attenuation is } 0.07 \text{ or } 7\%.$$

2.18

In this case we solve for f_c . Down 20 dB means that $-20 = 20\log_{10}(V_{out}/V_{in})$ so that $(V_{out}/V_{in}) = 10^{-1} = 0.1$

$$\left| \frac{V_{out}}{V_{in}} \right| = 0.1 = \frac{(1000 / f_c)}{\left[1 + (1000 / f_c)^2 \right]^{1/2}} \quad \text{Solving this for the critical frequency gives the}$$

answer, $f_c = 9.95$ kHz

2.19

The schematic for this filter is a low pass followed by a high pass,

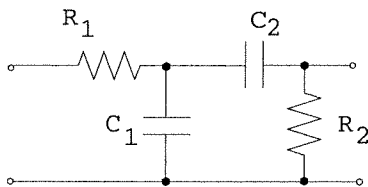

The critical frequency of the low pass will be 10 kHz and the critical frequency of the high pass which follows will be 100 Hz. This way a signal between 100 Hz and 10 kHz will be passed by the system. The values of components will thus be given by,

$$f_{c1} = 10,000 = 1 / (2\pi R_1 C_1) \quad \text{and} \quad f_{c2} = 100 = 1 / (2\pi R_2 C_2).$$

which can be written, $R_1 C_1 = 1.59 \times 10^{-5}$ and $R_2 C_2 = 1.59 \times 10^{-3}$.

Using a resistance ratio of 0.05 means that we have another equation, $R_2 / R_1 = 0.05$. Let's try $C_2 = 1 \mu\text{F}$, then $R_2 = 1591 \Omega$. From the resistance ratio we find $R_1 = 31.83$ k Ω and this gives $C_1 = 500$ pF. These are all reasonable component values.

A plot of this function shows the overall filter response:

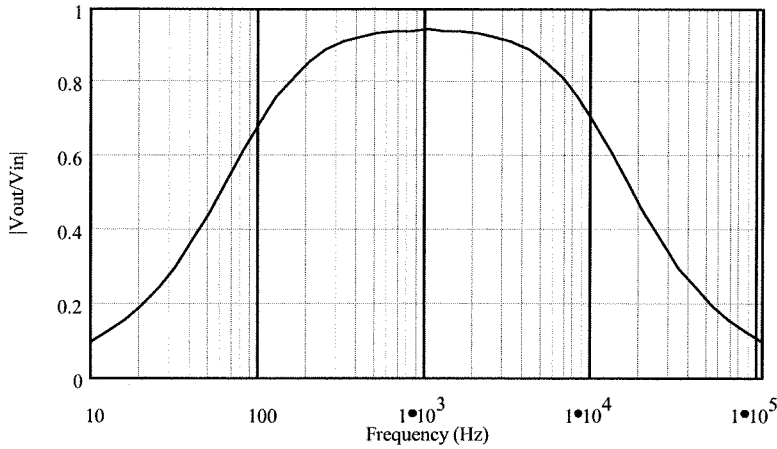

2.20

This is not an easy problem. The solution must account for the signal reduction at 200 Hz from the filter AND the reduction due to loading by the 10 kΩ input resistance of the amplifier. The circuit model, including the 10 kΩ input impedance amplifier is,

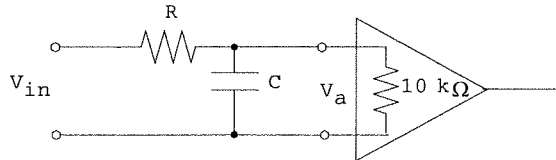

The problem specifies that, $|V_a/V_{in}| < 0.99$ at 200 Hz, i.e., no more than a 1% reduction. Using the Thevenin equivalent circuit of the filter we can model the system as,

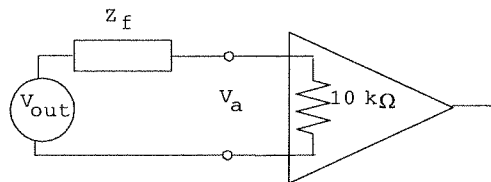

Where V_{out} is given by the filter equation and V_a is given by the loading,

$$\frac{V_{out}}{V_{in}} = \frac{1}{\sqrt{1 + (f/f_c)^2}} \quad \text{and} \quad \left| \frac{V_a}{V_{out}} \right| = \frac{10k + 0j}{|10k + Z_f|}$$

Since the product of the two transfer functions must be 0.99 at 200 Hz, let's make the filter transfer function 0.995 so that the loading must be 0.995, since $(0.995)(0.995) \approx 0.99$.

Let's first find the critical frequency for which $|V_{out}/V_{in}| = 0.995$ at 200 Hz,
 $0.995 = [1 + (200/f_c)^2]^{-1/2}$ or, squaring, $0.99^{-1} = 1 + (200/f_c)^2$

which gives, $(200/f_c) = 0.1004$ so that $f_c = 1992$ Hz where $f_c = 1/(2\pi RC)$

Now Z_f is the impedance of R and C in parallel assuming zero source impedance. Thus,

$$Z_f = \frac{R/j\omega C}{R + 1/j\omega C} = \frac{R}{1 + j\omega RC} = \frac{R}{1 + (\omega RC)^2} (1 - j\omega RC) \quad \text{But } RC = (1/2\pi f_c) \text{ so } Z_f \text{ can be}$$

written in the form,

$$Z_f = \frac{R}{1 + (f/f_c)^2} [1 - j(f/f_c)] = \frac{R}{1 + (200/1992)^2} (1 - 200j/1992)$$

or,

$$Z_f = 0.99R(1 - .1004j)$$

Now the loading condition can be written,

$$\frac{V_a}{V_{out}} = 0.995 = \frac{10000}{|10000 + .99R(1 - .1004j)|}$$

This can be solved for $R = 50.1 \Omega$ so that $C = 1/(2\pi Rf_c) = 1.6 \mu\text{F}$.

The attenuation of the 4 to 5 kHz noise is found from the same filter and loading equations with $f = 4 \text{ kHz}$ and 5 kHz .

The above equations show that at 4 kHz , $V_a/V_{in} = 0.45$ and at 5 kHz , $V_a/V_{in} = 0.37$. So the noise is reduced by about 30 to 50%.

2.21

We find the critical frequencies from the requirements of signal reduction at 500 Hz and 500 kHz . First let's reduce the voice (500 Hz) by 80%, which means the voltage ratio will be 0.2. This is the high pass filter so we have,

$$0.2 = \frac{(500/f_H)}{\sqrt{1+(500/f_H)^2}} \text{ which gives } f_H = 2.45 \text{ kHz}$$

Now for reduction of the 500 kHz signal by 90% we are using the low pass section of the filter,

$$0.1 = \frac{1}{\sqrt{1+(500000/f_L)^2}} \text{ which gives } f_L = 50 \text{ kHz}$$

From the critical frequency equations we find, $R_L C_L = 6.49 \times 10^{-9}$ and $R_H C_H = 3.18 \times 10^{-6}$. Let's try $C_L = 0.05 \mu\text{F}$, then $R_L = 1300 \Omega$. Since the ratio is specified as 0.02, $R_H = 1300 \Omega / 0.02 = 65 \text{ k}\Omega$. This leaves only C_L , which is found to be $C_H = 3.18 \times 10^{-6} / 65 \times 10^3 \approx 50 \text{ pF}$.

To find the effect on the bandpass frequency let us evaluate the response at the half band frequency of 5.5 kHz using Equation 2.25. The actual critical frequencies are $f_L = 2448 \text{ Hz}$ and $f_H = 48970 \text{ Hz}$. Thus we have,

$$\left| \frac{V_{out}}{V_{in}} \right| = \frac{(48970)(5500)}{\sqrt{(5500^2 - (48970)(2448))^2 + 5500^2 (2448 + 1.02(48970))^2}} = 0.89$$

so there is about an 11% reduction of the pass band.

2.22

Equations 2.27 for the twin-T filter allow determination of component values. In this case we want to reject 4.5 kHz , so we have $4.5 \text{ kHz} = 0.785f_c$, which gives $f_c = 5.73 \text{ kHz}$. Thus we find the values of the resistor and capacitor as, $RC = 1/(2\pi f_c) = 2.78 \times 10^{-5}$. Let's try $C = 0.01 \mu\text{F}$, then $R = 2.78 \text{ k}\Omega$. The grounding resistor and capacitor are then determined from $R_1 = \pi R / 10 = 873 \Omega$ and $C_1 = 10C / \pi = 0.03 \mu\text{F}$.

Effect on the signal frequencies can be estimated from the graph of Figure 2.24. For the lower signal frequency we form a ratio of $f/f_c = 1/5.73 = 0.175$. From the graph this gives an output ratio of about 0.7 so about 30% of the signal is lost. At 10 kHz the ratio is 1.7 and you can see that the output is about 0.3 so about 70% of the signal is lost. The upper end of 50 kHz has a ratio of 8.73 and the graph shows that the output is at about 0.9 so only 10% is lost.

2.23

In the case of the inverting amplifier we need two so that the overall gain will be +100. Thus the following circuit will satisfy this need. The first has a gain of -100 and an input impedance of $1.5 \text{ k}\Omega$ and the second a gain of -1.

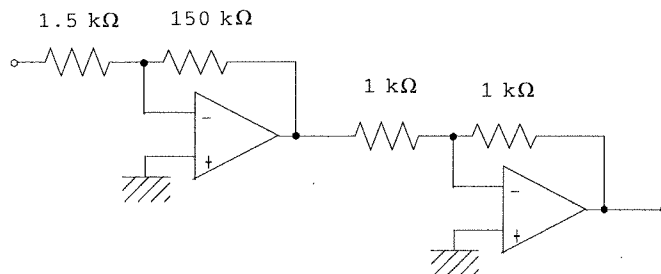

A noninverting amplifier can be constructed with only one op amp, as:

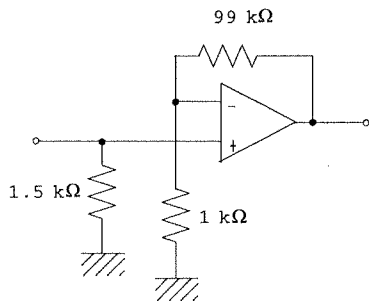

2.24

A differential amplifier with a gain of 22 can be constructed as follows:

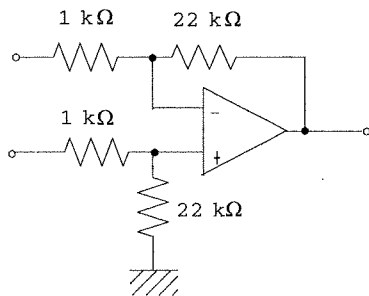

2.25

If the input to an integrator is $V_{in} = \text{constant}$, then the output is,

$$V_{out} = -(1/RC)(V_{in})t = -0.1V_{in}t \quad \text{since } RC \text{ is given to be } 10.$$

We need this to be $0.5t$ so it is clear that $V_{in} = -5$ Volts. The following circuit will provide this. We have assumed that the -5 volts must be supplied from the -15 V supply and have taken into account loading.

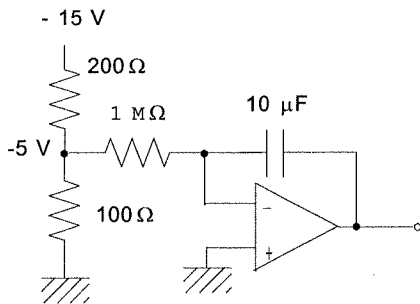

2.26

The first figure shows the circuit with a summing amplifier and the second with a differential amplifier. A voltage follower may be necessary in both to prevent loading the source.

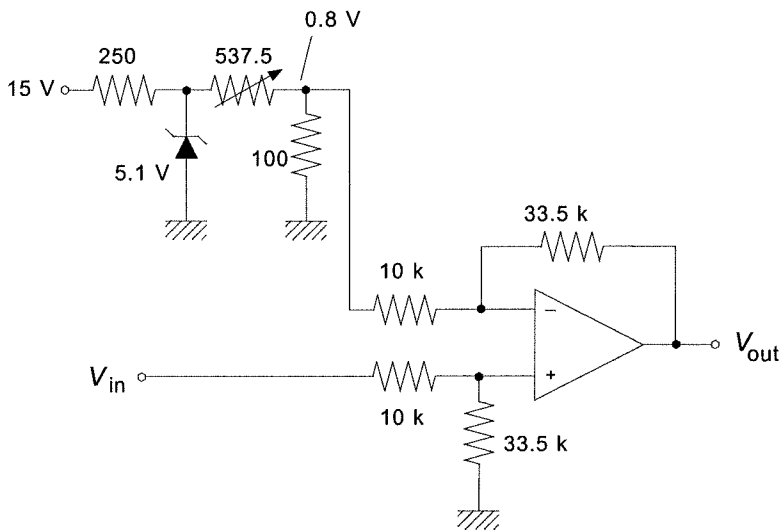
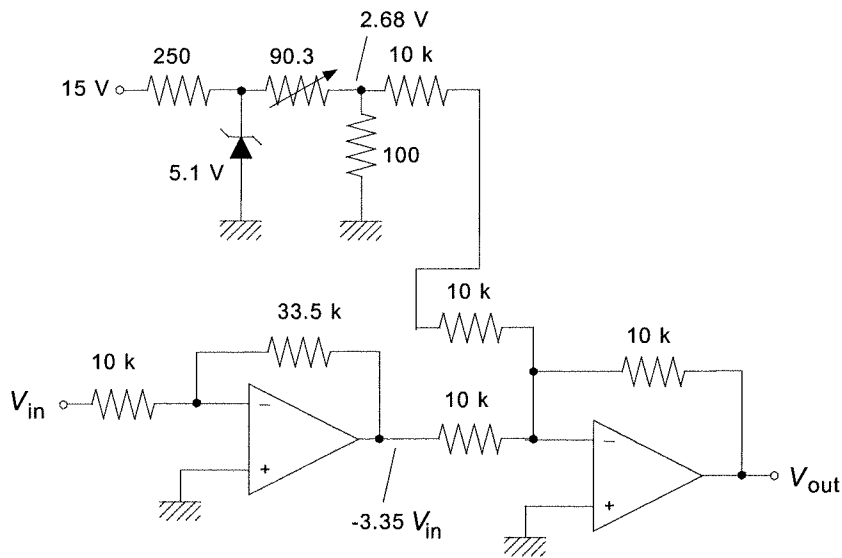

2.27

The amplifier gain is given by $A = R_2/R_1 = 470/2.7 = 174$

The common mode gain is given by $A_{cm} = 0.087/2.5 = 0.0348$

Thus, $CMRR = A/A_{cm} = 174/0.0348 = 5000$

and then, $CMR = 20\log_{10}(CMRR) = 20\log_{10}(5000) = 74 \text{ dB}$

2.28

The circuit model for the derivation is:

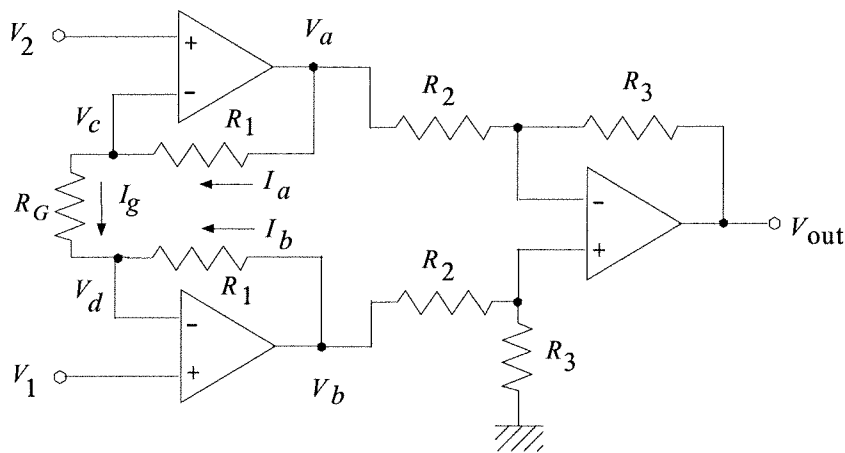

Assumptions are: (1) no current into op amp inputs, (2) no voltage across op amp inputs, (3) no loading of differential amplifier by first stages, (4) zero source resistances.

A. From (2) we conclude $V_c = V_2$ and $V_d = V_1$

B. From (3) we conclude $V_{out} = (R_3/R_2)(V_b - V_a)$ (standard differential amplifier)

C. From (1) we conclude, $I_g - I_a = 0$ and $I_g + I_b = 0$

D. From Ohm's Law we can write these currents in terms of voltages and resistances, also using A.

$$\frac{V_2 - V_1}{R_g} - \frac{V_a - V_2}{R_1} = 0 \qquad \frac{V_2 - V_1}{R_g} + \frac{V_b - V_1}{R_1} = 0$$

We solve the first for V_a and the second for V_b ,

$$V_a = V_2 + (R_1/R_g)(V_2 - V_1) \text{ and } V_b = V_1 - (R_1/R_g)(V_2 - V_1)$$

This result is combined with B. and some algebra to find the expression;

$$V_{out} = \left(1 + \frac{2R_1}{R_g}\right) \frac{R_3}{R_2} (V_1 - V_2)$$

2.29

This design is accomplished by switching in different values of R_g to provide the desired gains. The net gain is given by the express just above. Suppose we make $R_3/R_2 = 1$ then the gain variation is given by the expression,

$$G = (1 + 2R_1/R_g)$$

Solving this for R_g ,

$$R_g = 2R_1/(G-1)$$

Let's pick $R_1 = 100 \text{ k}\Omega$

$$G = 1 \qquad R_g = \infty \text{ (open circuit)}$$

$$G = 10 \qquad R_g = 22.2 \text{ k}\Omega$$

$$G = 100 \qquad R_g = 2.02 \text{ k}\Omega$$

$$G = 1000 \qquad R_g = 200 \text{ }\Omega$$

We pick $R_3 = R_2 = 10 \text{ k}\Omega$. The following circuit results:

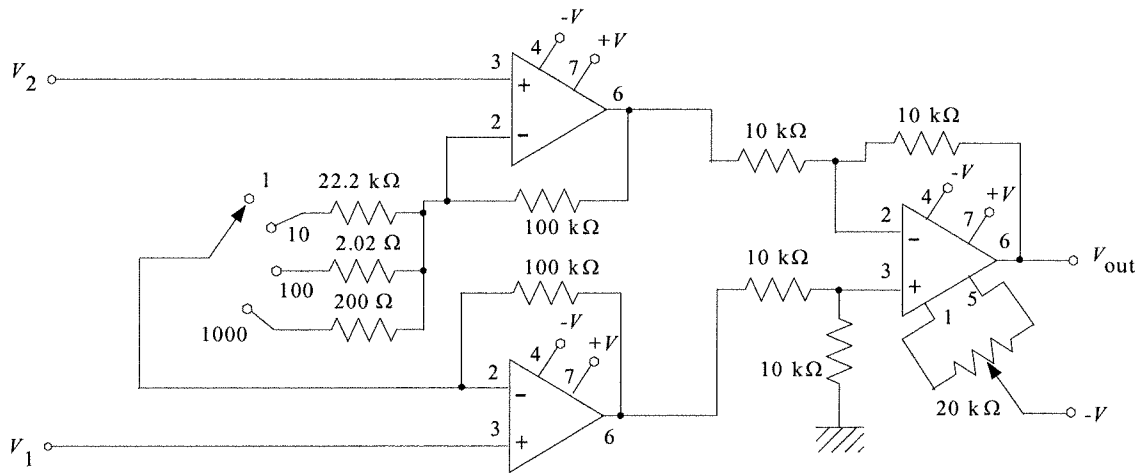

2.30

This can be provided by a summing amplifier with a gain of $1/3$ on all inputs, followed by a unity gain inverter to get the polarity right.

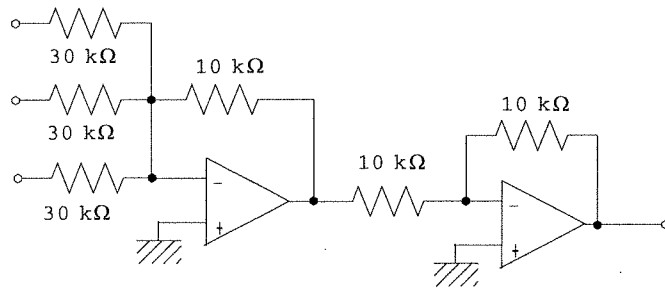

2.31

This equation consists of a sum of an gain term and an integration term. Thus we form the circuit from these same elements as shown below. The gains are adjusted to provide the gain of 10 and an integral gain of 4.

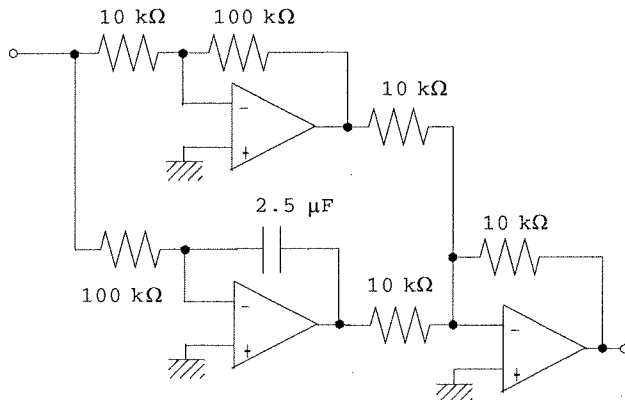

2.32

For the V-to-I converter we have, from Equations (2-35) and (2-36),

$$I = -(R_2/R_1R_3)V_{in} \text{ provided, } R_1(R_3 + R_5) = R_2R_4$$

Thus it is clear that one equation that can be formed is,

$R_2/(R_1R_3) = 2.1 \times 10^{-3}$ and that $V_{in} = - |V_{in}|$ which means that an inverter will be needed at the front end.

This means there are two equations and five unknowns. So, we can select three, using good judgement of course. Let's try $R_1 = R_3 = 1 \text{ k}\Omega$. Then we find R_2 as,

$$R_2 = (10^3)(10^3)(2.1 \times 10^{-3}) = 2.1 \text{ k}\Omega$$

We can still pick one resistor, let's take $R_5 = 500 \Omega$ then R_4 is found to be,

$$(1 \text{ k}\Omega)(1 \text{ k}\Omega + 0.5 \text{ k}\Omega) = (2.1 \text{ k}\Omega)R_4$$

$$R_4 = 1.5 \text{ k}\Omega/2.1 = 714 \Omega$$

These satisfy the requirements. The circuit is as in Figure 2.33 but an inverter is needed to give $-|V_{in}|$ as the input. The maximum load is found from Equation (2-40).

$$R_{ML} = \frac{(R_4 + R_5)(V_{sat}/I_M - R_3)}{(R_3 + R_4 + R_5)}$$

$$R_{ML} = \frac{(714 + 500)(12/0.005 - 1000)}{(1000 + 714 + 500)}$$

$$R_{ML} = 768 \Omega$$

Of course many other solutions are possible.

2.33

Let us first establish the range of bridge off-null voltage for the given range of R_4 variation. It is clear that the bridge will be nulled at $R_4 = 120 \Omega$ so that $\Delta V = 0$. When the resistance is 140Ω the off-null voltage will be,

$$\Delta V = 10 \left[\frac{120}{(120 + 120)} - \frac{140}{(120 + 140)} \right]$$

$$\Delta V = -0.385 \text{ volts}$$

The required signal conditioning must satisfy the following relation:

$$V_{out} = k\Delta V + V_0$$

where when $\Delta V = 0$ ($R_4 = 120 \Omega$) $V_{out} = 0 \text{ V}$ and when $\Delta V = -0.385 \text{ volts}$ ($R_4 = 140 \Omega$), $V_{out} = 5.0 \text{ volts}$.

This gives two equations for the two unknowns, k and V_0 ,

$$0 = k(0) + V_0 \text{ therefore, } V_0 = 0$$

$$5.0 = -.385k$$

$$k = -12.987 \sim -13$$

so,

$$V_{out} = 13\Delta V$$

This is provided by the following differential amplifier circuit. The polarity is taken into account by how the bridge is connected. The following plot of V_{out} versus R_4 shows that the relation is not exactly linear but quite close. The nonlinearity is a result of the bridge.

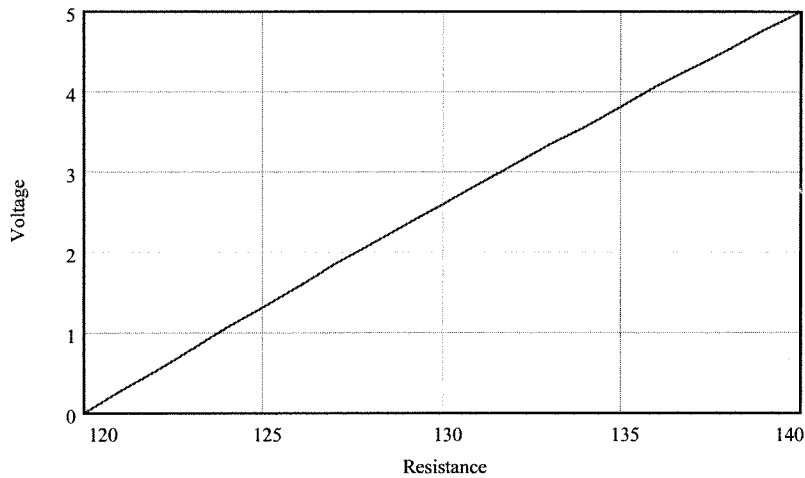
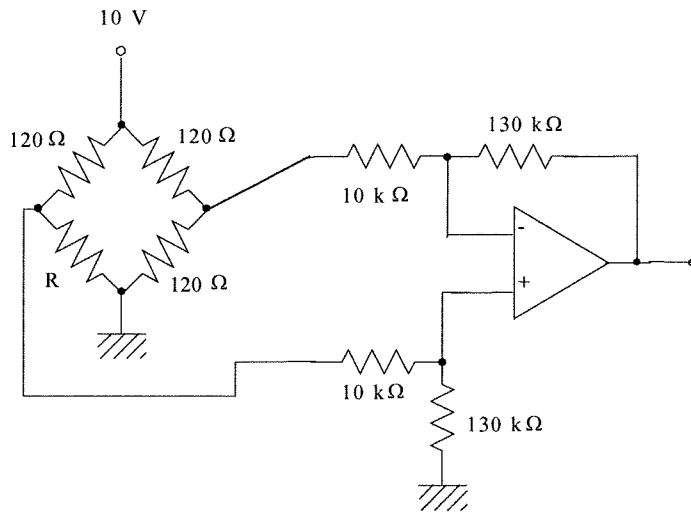

2.34

Example 2.2 involves a sensor used in a divider. The example shows that as the transducer resistance varies from 4 kΩ to 12 kΩ, the divider voltage varies from 1.43 to 2.73 volts. A signal conditioning circuit is needed which satisfies,

$$V_{out} = kV_{in} + V_0$$

where k and V_0 are determined to satisfy the conditions:

$$V_{out} = 0 \text{ V when } V_{in} = 1.43 \text{ V (4 k}\Omega\text{)}$$

$$V_{out} = 5 \text{ V when } V_{in} = 2.73 \text{ V (12 k}\Omega\text{)}$$

Thus,

$$0 = 1.43k + V_0$$

$$5 = 2.73k + V_0$$

subtracting allows k to be found as, $k = 5/(2.73-1.43) = 3.85$

and then $V_0 = -1.43k = -1.43(3.85) = -5.51 \text{ V}$. Thus the relation is,

$$V_{out} = 3.85V_{in} - 5.51$$

or,

$$V_{out} = 3.85(V_{in} - 1.43)$$

Now, to develop an appropriate circuit we must note that the effective output resistance of the divider source is, at the mid-range, about 4 kΩ. To avoid loading problems the signal conditioning circuit must have a much larger input resistance. There are many circuits. The following one isolates the divider with a voltage follower and uses the second relation above with a differential amplifier. the 1.43 volts is provided by another divider.

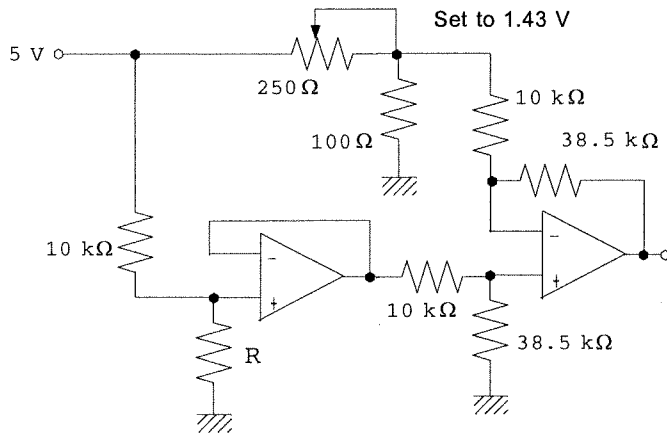

2.35

The input conditions, from Problem 2.3, and the requirements of this problem can be summarized as follows:

R	$V_D = V_{in}$	V_{out}
520Ω	4.90 V	0 V
2500Ω	1.67 V	5 V

The equation relating V_{in} and V_{out} is,

$$V_{out} = kV_{in} + V_0$$

Thus we have the equations,

$$0 = 4.90k + V_0$$

$$5 = 1.67k + V_0$$

subtracting, $k = 5/(1.67-4.9) = -1.55$ and so $V_0 = 4.9(1.55)$. The final relation is,

$$V_{out} = -1.55V_{in} + 7.585$$

The following op amp circuit provides this result.

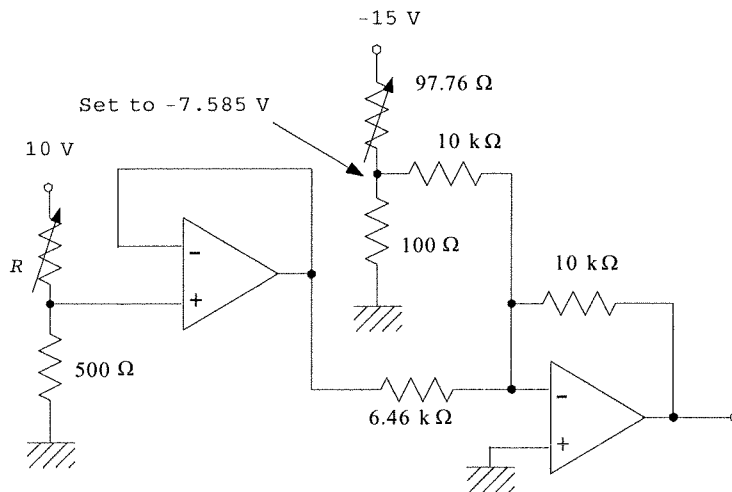

2.36

Let us first develop an equation for the output voltage varying linearly with R ,

$$V_{out} = KR + V_0$$

Using the given facts we form,

$$0 = K(1 \text{ k}\Omega) + V_0$$

$$5 = K(5 \text{ k}\Omega) + V_0$$

Subtracting, $K = 5/4 = 1.25 \text{ V/k}\Omega$ and $V_0 = -1.25 \text{ V}$. So the relation is $V_{out} = 1.25R - 1.25$

An inverting amplifier has a transfer function of, $V_{out} = -(R_2/R_1)V_{in}$. If we let $R_2 = R$ and $V_{in}/R_1 = 1.25$ then we will have the first part of the required equation. We let $V_{in} = 1.25$ V and $R_1 = 1$ k Ω . The rest is just a summing amplifier, which will also invert the sign. The circuit is as follows:

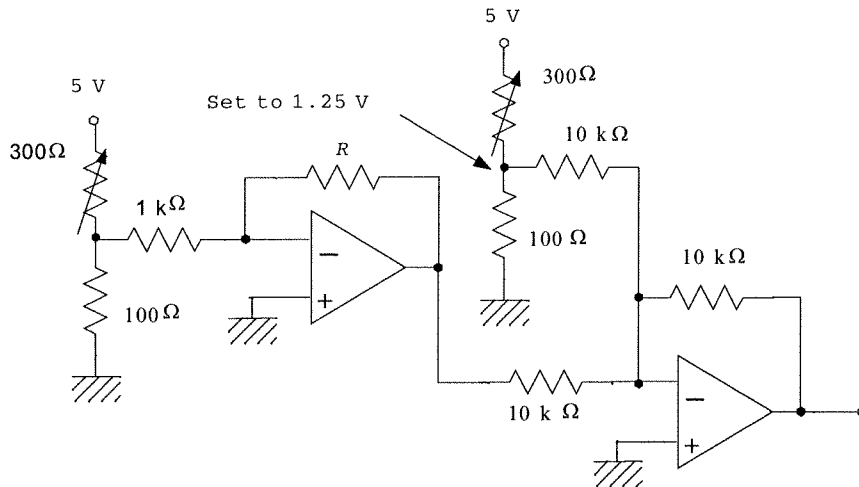

2.37

The current can be converted to a voltage by a current to voltage op amp circuit. This gives $V = -IR$, so if we make $R = 100 \Omega$ then the voltage will be $V = -100I$. For a current range of 4 to 20 mA this will mean a voltage of -0.4 to -2.0 volts. The setpoint will be 0.95 volts. A summing amplifier can be used to construct the error voltage, provide the needed scale factor and invert the sign. An error of 1 mA will provide an error voltage of 0.1 volts, so we need a gain of 5 to obtain the desired scale factor of 0.1 V/mA.

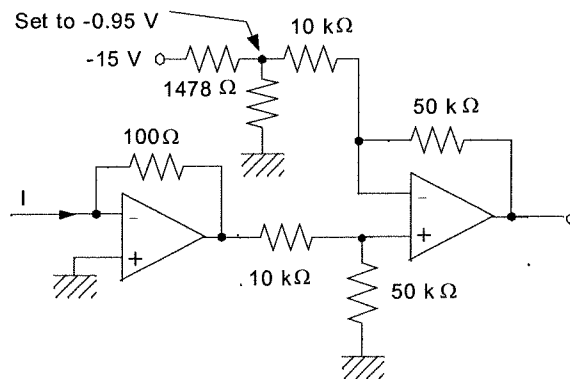

2.38

First we get an equation relating V_{out} and R from the equation for a straight line,

$$V_{out} = mR + V_0$$

Using the required relations,

$$-2 = 25000m + V_0$$

$$+2 = 1500m + V_0$$

Solving we find, $m = -1.70 \times 10^{-4}$ and $V_0 = 2.255$

so,

$$V_{out} = -1.7 \times 10^{-4} R + 2.255$$

This equation can be satisfied by an inverting amplifier with R in the op amp feedback and a summing amplifier to provide the offset voltage. The current in the sensor resistor, R , must be kept below a limit so that the dissipation does not exceed 2.5 mW. This is provided by making the input resistance and fixed input voltage within certain limits since the current through the feedback resistor is the same as the current through the input resistor.

$$P_{max} = 0.0025 \text{ W} = I^2 \times R_{min}$$

$$I = [0.0025/1500]^{1/2} = 1.3 \text{ mA}$$

So, let's use an input current of 1 mA to be sure. In the circuit below the input divider voltage is -1 volt and the input resistor is 1 kΩ so that the fixed input current is 1 mA as required.

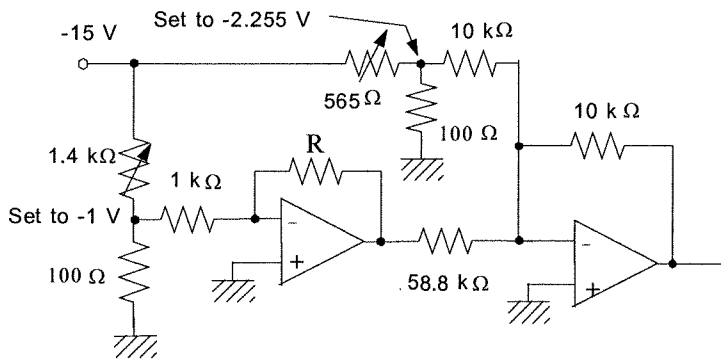

2.39

As the pressure varies from 50 to 150 psi the sensor voltage will vary from (50 psi)(100 mV/psi) = 5 volts to (150 psi)(100 mV/psi) = 15 volts. The signal conditioning must convert this into 0 to 2.5 volts,

$$0 = 5m + V_0$$

$$2.5 = 15m + V_0$$

solving,

$$m = 0.25 \text{ and } V_0 = -1.25$$

The equation for the signal conditioning is thus, $V_{out} = 0.25V_{in} - 1.25 = 0.25(V_{in} - 5)$

This can be provided by a differential amplifier with a fixed 5 volts on one input. Voltage followers are used to avoid loading the source because of its relatively low 2.5 kΩ output resistance.

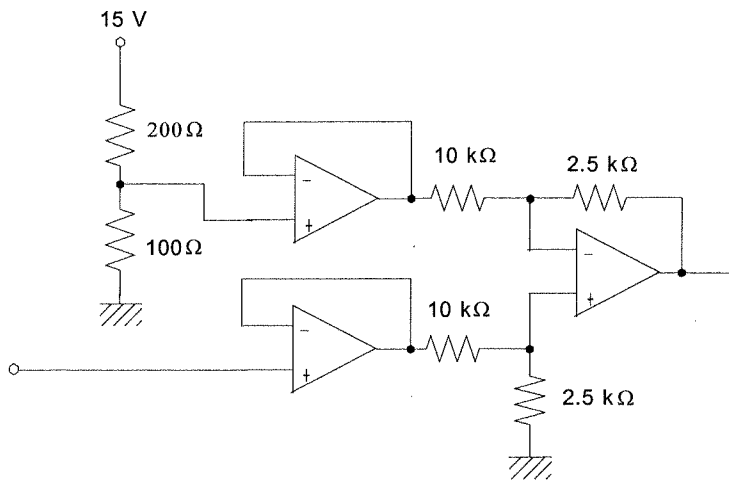

2.40

From the known static transfer function of $1.45Q^{1/2}$ the output voltage range can be found as,

$$\text{For } Q_1 = 20 \text{ gal/min, } V_1 = 1.45[20]^{1/2} = 6.48 \text{ volts}$$

$$\text{For } Q_2 = 30 \text{ gal/min, } V_2 = 1.45[30]^{1/2} = 7.94 \text{ volts}$$

Since the output resistance is only 2 kΩ, we will need a voltage follower on the output of the sensor. The basic period of the signal is 30 s or a frequency of 0.033 Hz, which is 1800 times the noise frequency of 60 Hz. Thus a simple RC low pass filter can be used to attenuate the 60 Hz noise by, say, 99%, while having very little effect on the data. We find the critical frequency from,

$$0.01 = 1/[1 + (60/f_c)^2]^{1/2} \text{ then, squaring and inverting gives,}$$

$$10000 = 1 + (60/f_c)^2 \text{ and so solving}$$

for the critical frequency gives, $f_c = 0.6 \text{ Hz}$.

Ok, to find the signal conditioning to provide the required -2.5 to +2.5 volt output we first find the filter output at 20 and 30 gal/min.

$V_{1in} = 6.48/[1 + (0.033/0.6)^2]^{1/2} = 6.47$ volts
 $V_{2in} = 7.94/[1 + (0.033/0.6)^2]^{1/2} = 7.93$ volts
 so, the signal conditioning equation will be,

$$V_{out} = mV_{in} + V_0$$

and,

$$-2.5 = 6.47m + V_0$$

$$2.5 = 7.93m + V_0$$

These equations give solutions of $m = 3.42$ and $V_0 = 24.63$ V. So we can write,

$$V_{out} = 3.42(V_{in} - 7.2)$$

The following circuit shows how the requirements of the problem can be easily satisfied.

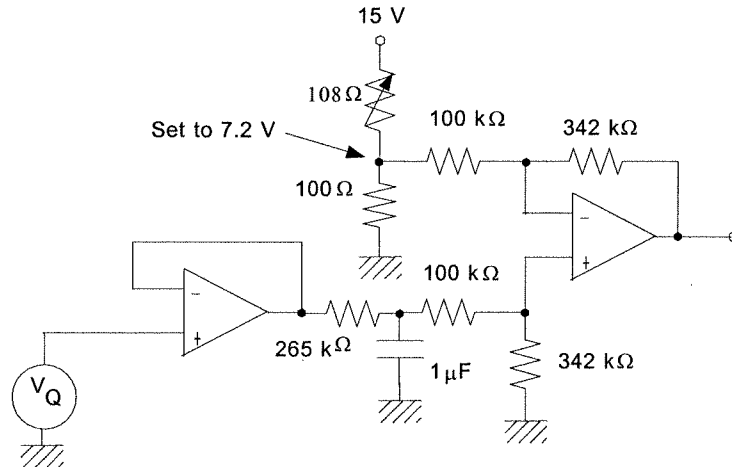

The 0.8 vrms comes out of the filter as,

$0.8/[1 + (60/0.6)^2]^{1/2} = 0.008$ volts. The full scale output voltage range is 5.0 volts so the percent FS of the noise on the output is,

$$(0.008/5) \times 100 = 0.16\%$$

The following graph shows the output plotted against flow. Obviously there is nonlinearity because the voltage and flow are related by a square-root.

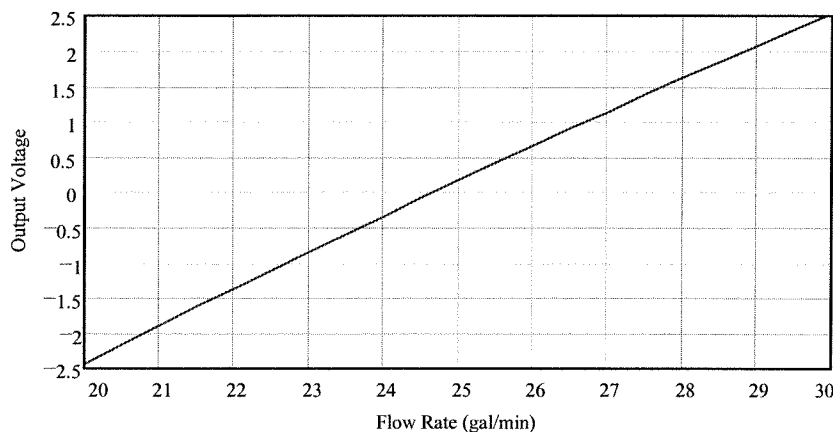

Supplementary Problems

S2.1

Round-off errors can contribute significant errors in problems like this. We will use four significant figures for all calculations.

(a) Ok, when the weight is 0.00 lbs the sensor resistance is 119 Ω. So, from the bridge null equation we can determine the correct value for the leg with R_x , call it R_1 ,

$$119R_1 = 120^2 \quad \text{so } R_1 = 120^2/119 = 121.0 \Omega$$

Now we set this equal to the equivalent resistance of everything in that leg,

$$121.0 = 100 + \frac{24(R_z + 70)}{24 + R_z + 70}$$

$$21.0 = \frac{24R_z + 1680}{R_z + 94}$$

Solving this for the unknown gives, $R_z = 98.00 \Omega$

(b) Again, the bridge null equation is used, but now we solve for R_w ,

$$R_w = \frac{120^2}{R_1} = \frac{120^2}{100 + \frac{24(R_z + 70)}{R_z + 94}}$$

where R_z varies from 0 to 200 Ω . Therefore we find

$$\text{When } R_z = 0 \Omega, \quad R_w = 122.2 \Omega$$

$$\text{When } R_z = 200 \Omega, \quad R_w = 118.0 \Omega$$

(c) When the weight is 299 lbs the sensor resistance is 127 Ω and if it is nulled at 0.00 lbs then $R_z = 98.00 \Omega$. So, we use the bridge off-null equation to find the voltage,

$$\Delta V = 5.1 \left[\frac{120}{120 + R_1} - \frac{R_w}{R_w + 120} \right]$$

$$\Delta V = 5.1 \left[\frac{120}{120 + 100 + \frac{24(70 + 98)}{98 + 94}} - \frac{127}{127 + 120} \right] = -0.0828 \text{ V}$$

where the negative just results from whether we subtract bridge voltage a from b or vice versa.

S2.2

(a) Well, shucks, the previous problem found that the bridge voltage at 299 lbs was 0.0828 volts so if we want a reading of 2.99 the gain must be, $K = 2.99/0.0828 = 3.1$

(b) The following differential amplifier will provide the required gain. Notice that for the output to

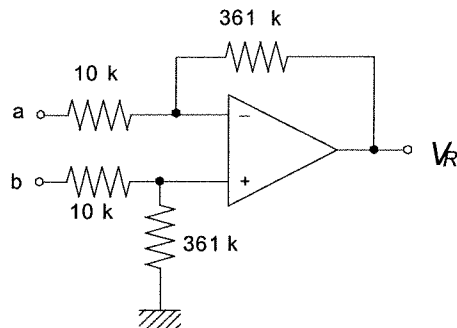

have the correct polarity we connect bridge point a to the upper amplifier input.

S2.3

(a) Well, the resistance changes linearly from 119 to 127 Ω as the weight changes from 0 to 299 lbs so the resistance at 150 lbs can be found from a simple linear relationship,

$$R_{150} = 119 + \frac{127 - 119}{299 - 0} (150 - 0) = 123.0 \Omega$$

The bridge off-null voltage will be: (assuming $R_z = 98.00 \Omega$),

$$\Delta V = 5.1 \left[\frac{123}{123 + 121} - \frac{120}{120 + 121} \right] = 0.04206 \text{ V}$$

So the DVM will read, $V_{150} = 36.1(0.04206) = 1.518$ so the DVM would read 151. Thus there is a 1 pound error.

(b) For the reading to be accurate at 150 lb requires a different gain,

$$K = 1.50/0.04206 = 35.7$$

If this gain is used the voltage at 0.0 lbs will be,

$$V_o = (35.7)(5.1) \left[\frac{119}{119 + 120} - \frac{120}{120 + 121} \right] = -.003 = 0.00 \text{ (DVM)}$$

so there is no error for 0.0 lbs. For 299 lbs we have,

$$V_{299} = (35.7)(5.1) \left[\frac{127}{127 + 120} - \frac{120}{120 + 121} \right] = 2.958 = 2.96 \text{ (DVM)}$$

So there is a -3 lb error at the high end.

(c) The following figure shows the slight nonlinearity of the readout.

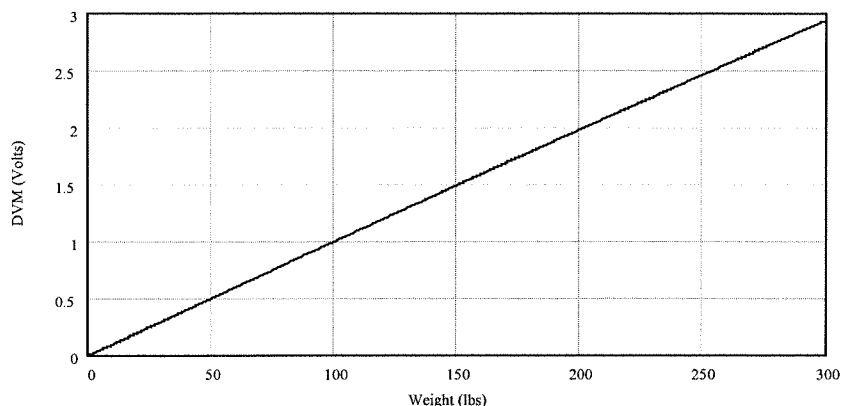

S2.4

We can simply use a low pass filter to block passage of the 50-55 kHz signal from one channel and a high pass filter to block the 1-1.5 kHz from another channel:

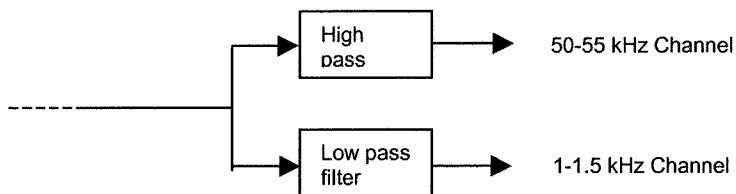

In both filters the critical frequencies are determined by the requirement that the signal be down no more than 3 dB (0.707). Thus we form the equations, (all frequencies in kHz)

$$0.707 = \frac{50/f_H}{\sqrt{1+(50/f_H)^2}} \quad \text{and} \quad 0.707 = \frac{1}{\sqrt{1+(1.5/f_L)^2}}$$

These are solved for the critical frequencies, OR, we simple recall that the critical frequencies ARE those frequencies for which the output is down 3 dB. In either case we find $f_H = 50$ kHz and $f_L = 1.5$ kHz

For the high pass we have $R_H C_H = 3.183 \times 10^{-6}$. If we pick $C_H = 0.001 \mu\text{F}$ then $R_H = 3.183 \text{ k}\Omega$. Similarly we find $R_L C_L = 1.061 \times 10^{-4}$ so if we pick $C_L = 0.1 \mu\text{F}$ then $R_L = 1.061 \text{ k}\Omega$.

The maximum effects of the cross-over will be at 50 kHz for the low pass and 1.5 kHz for the high pass. Using the high and low pass equations we find,

$$\left| \frac{V_{out}}{V_{in}} \right|_{50} = \frac{1}{\sqrt{1+(50/1.5)^2}} = 0.03 \quad \text{and} \quad \left| \frac{V_{out}}{V_{in}} \right|_{1.5} = \frac{(1.5/50)}{\sqrt{1+(1.5/50)^2}} = 0.03$$

So, for both channels the cross-over leaves about 3% of the other signal amplitude.

S2.5

We start by forming an equation between the required output voltage and the sensor resistance,

$$V = mR_s + V_0$$

The slope and intercept can be found from the two conditions of the problem;

$$0.0 = (250 \text{ k}\Omega)m + V_0$$

$$1.0 = (120 \text{ k}\Omega)m + V_0$$

Subtracting the first from the second gives, $1.0 = (130 \text{ k}\Omega)m$ or $m = -1/130 \text{ k}\Omega$. The first equation then gives, $V_0 = 250/130 = 1.923$. So we have,

$$V = -R_s/130 \text{ k}\Omega + 1.923$$

There are several ways we could provide this but the most obvious is an inverting amplifier for the first term with the sensor in the feedback and then a summing or differential amplifier to provide the 1.923 V bias.

The following circuit shows how the inverting amplifier can provide the form of the first term of the equation,

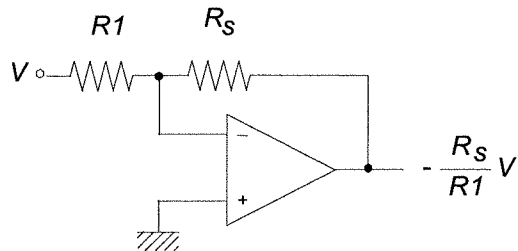

where we require, $(V/R1) = 1/130$. We also must satisfy the requirement of power dissipation below $100 \mu\text{W}$ in the sensor. This means a limitation on the current through the sensor, which is the same as the current through $R1$, $I = V/R1$. The power dissipated by the sensor is $I^2 R_s$ so we can form an equation for the current as, $I < (100 \mu\text{W}/R_s)^{1/2}$. The minimum current should be used, which occurs for maximum sensor resistance. Therefore we stipulate $I < (100 \mu\text{W}/250 \text{ k}\Omega)^{1/2} = 20 \mu\text{A}$. Thus two conditions must be satisfied, $(V/R1) = 1/130$ and $(V/R1) < 20 \mu\text{A}$. Many combinations can provide this but notice that if we set $V = 1$ volt and $R1 = 130 \text{ k}\Omega$ then $I = 7.7 \mu\text{A}$ which well satisfies the power requirement. This then is followed by a differential amplifier to provide the 1.923 V bias. In order to make the polarities come out correct we used $V = -1$ volt. The following circuit shows the completed design.

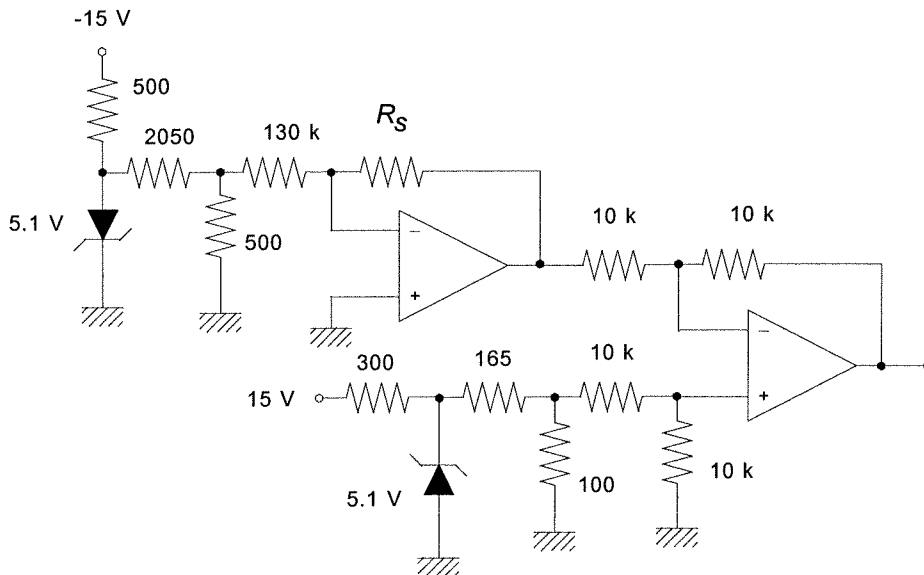

S2.6

As long as the input voltage is less than 1.4 volts the feedback resistance is $100 \text{ k}\Omega$ and so the gain is given by -1 and the output is simply, $V_{out} = -V_{in}$. When the input (and therefore output) reaches 1.4 volts $D1$ begins to conduct so that the feedback resistance changes to $50 \text{ k}\Omega$ (two $100 \text{ k}\Omega$ in parallel). Now the gain drops to $-1/2$ so the output is, $V_{out} = -1.4 - (V_{in} - 1.4)/2 = -0.7 - V_{in}/2$. As the input voltage continues to rise and output will go more negative. When the output reaches -

2.8 volts the 50 kΩ resistor in the feedback will be in parallel with the others and the gain will become -1/4. We find the value of input when this occurs from: $-2.8 = -0.7 - V_{in}/2$ or $V_{in} = 4.2$ volts. Now the equation for the output becomes, $V_{out} = -2.8 - (V_{in} - 4.2)/4 = -1.75 - V_{in}/4$. The following figure shows a plot of output voltage versus input voltage.

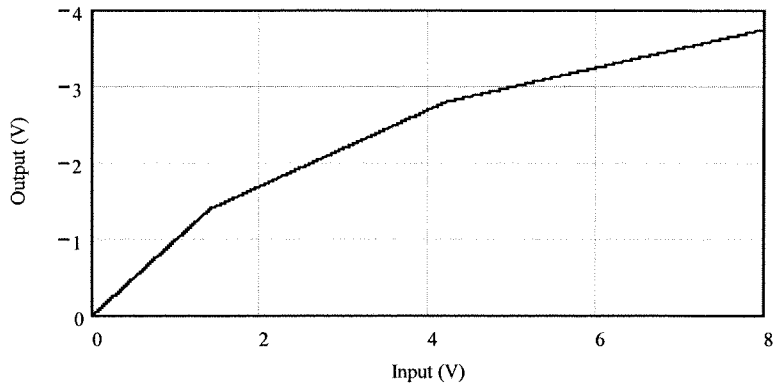

S2.7

First we find the "breaks" in pressure when the gain changes. The first is at 1.4 volts, so we have

$$p_1 = (1.4/0.035)^{1/2} = 6.32 \text{ psi}$$

The second is for

$$p_2 = (4.2/0.035)^{1/2} = 10.95 \text{ psi}$$

Thus the equations for output are:

$$p < 6.32 \quad V_{out} = -0.035p^2$$

$$10.95 > p > 6.32 \quad V_{out} = -1.4 - .035p^2/2 = -1.4 - 0.0175p^2$$

$$p > 10.95 \quad V_{out} = -1.75 - 0.035p^2/4 = -1.75 - 0.00875p^2$$

This result is plotted below. Notice that the output voltage is more nearly linear.

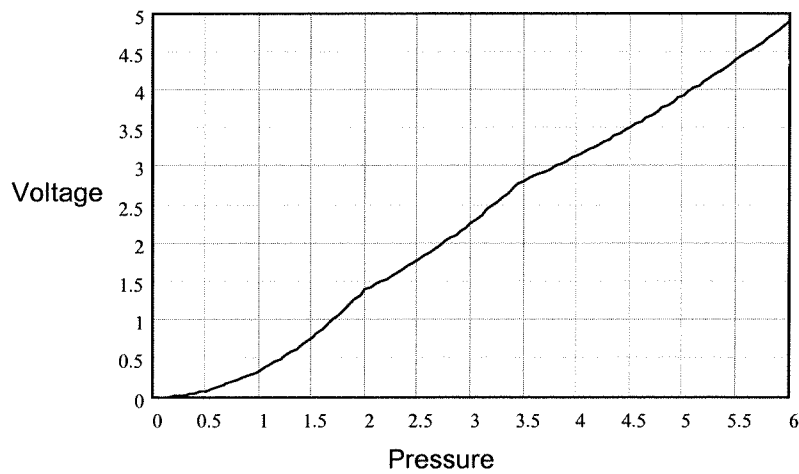

CHAPTER 3

3.1

The basic relations for conversions of binary are defined for a binary, $b_n b_{n-1} \dots b_1 b_0$ where the b 's are either a 1 or 0, then,

$$N_{10} = a_n 2^n + a_{n-1} 2^{n-1} + \dots + a_1 2^1 + a_0 2^0$$

For octal we just arrange the binary number in three-bit groups starting from the decimal point and use the relations

$$111 = 7_8, 110 = 6_8, \text{ etc, } 001 = 1_8 \text{ and } 000 = 0_8$$

For hex we use groupings of four and include the numbers,

$$1000 = 8H, 1001 = 9H, 1010 = AH, 1011 = BH, 1100 = CH$$

$$1101 = DH, 1110 = EH \text{ and } 1111 = FH$$

so,

(a) $1010 \Rightarrow 2^3 + 2^1 = 8 + 2 = 10_{10}$

$$1010 = 001\ 010 \Rightarrow 12_8$$

$$1010 \Rightarrow AH$$

(b) $111011 \Rightarrow 2^5 + 2^4 + 2^3 + 2^1 + 2^0 = 32 + 16 + 8 + 2 + 1 = 59_{10}$

$$111011 = 111\ 011 \Rightarrow 73_8$$

$$111011 = 0011\ 1011 \Rightarrow 3BH$$

(c) $010110 \Rightarrow 2^4 + 2^2 + 2^1 = 16 + 4 + 2 = 22_{10}$

$$010110 = 010\ 110 \Rightarrow 26_8$$

$$010110 = 0001\ 0110 \Rightarrow 16H$$

3.2

(a) $1011010 \Rightarrow 2^6 + 2^4 + 2^3 + 2^1 = 64 + 16 + 8 + 2 = 90_{10}$

$$1011010 = 001\ 011\ 010 \Rightarrow 132_8$$

$$1011010 = 0101\ 1010 \Rightarrow 5AH$$

(b) For this we must use the base 10 fractional to binary fractional relationship,

Given a binary fraction, $0.b_1 b_2 \dots b_n$ then,

$$0.N_{10} = b_1 2^{-1} + b_2 2^{-2} + \dots + b_n 2^{-n}$$

Octal and Hex fractionals are found by the regular 3 and 4 groupings of bits. So,

$$0.1101 \approx 2^{-1} + 2^{-2} + 2^{-4}$$

$$= 0.5 + 0.25 + 0.0625 = 0.8125_{10}$$

$$0.1101 = 0.110\ 100 \Rightarrow 0.64_8$$

$$0.1101 \Rightarrow 0.DH$$

(c) 1011.0110 treating the whole and fractional parts separately,

$$1011 \Rightarrow 2^3 + 2^1 + 2^0 = 8 + 2 + 1 = 11_{10} \text{ and } 0.0110 \Rightarrow 2^{-2} + 2^{-3} = 0.25 + 0.125 = 0.375_{10}$$

$$\text{thus, } 1011.0110 \Rightarrow 11.375_{10}$$

$$1011.0110 = 001\ 011.011\ 000 \Rightarrow 13.3_8$$

$$1011.0110 \Rightarrow B.6H$$

3.3

If we find the binary first then the octal and hex can be found easily using the groupings of 3 and 4 bits.

(a) $21/2 = 10 + 1/2$ so $b_0 = 1$

$$10/2 = 5 + 0$$
 so $b_1 = 0$

$$5/2 = 2 + 1/2$$
 so $b_2 = 1$ $2/2 = 1 + 0$ so $b_3 = 0$

$$1/2 = 0 + 1/2$$
 so $b_4 = 1$ so $21_{10} \Rightarrow 10101_2$

and, $10101 = 010\ 101 \Rightarrow 25_8$

$$10101 = 0001\ 0101 \Rightarrow 15H$$

(b) Lets do successive division by 8 instead to find the octal first,

$$630/8 = 78 + 6/8$$
 so $d_0 = 6$

$$78/8 = 9 + 6/8$$
 so $d_1 = 6$

$$9/8 = 1 + 1/8$$
 so $d_2 = 1$

$$1/8 = 1 + 0/8$$
 so $d_3 = 1$

$$630_{10} \Rightarrow 1166_8$$

using binary groupings we see that,

$$1166_8 \Rightarrow 001\ 001\ 110\ 110 = 100110110_2 \text{ and,}$$

$$1001110110 = 0010\ 0111\ 0110 \Rightarrow 276H$$

(c) On this one lets successively divide by 16 to get the hex first,

$$427/16 = 26 + 11/16 \quad \text{so } a_1 = 11_{10} = BH$$

$$26/16 = 1 + 10/16 \quad \text{so } a_2 = 10_{10} = AH$$

$$1/16 = 0 + 1/16 \quad \text{so } a_3 = 1$$

$$427_{10} = 1ABH$$

Using groupings we get the binary and then the octal,

$$1ABH \approx 000110101011 = 110101011_2 \quad \text{and} \quad 110101011 = 110\ 101\ 011 \Rightarrow 653_8$$

3.4

The whole number and fractional parts are converted separately,

$$27_{10} \text{ is } 27/2 = 13 + 1/2 \quad \text{so } b_0 = 1$$

$$13/2 = 6 + 1/2 \quad \text{so } b_1 = 1$$

$$6/2 = 3 + 0 \quad \text{so } b_2 = 0$$

$$3/2 = 1 + 1/2 \quad \text{so } b_3 = 1$$

$$1/2 = 0 + 1/2 \quad \text{so } b_4 = 1$$

$$27_{10} \Rightarrow 11011_2$$

For the fractional part we do successive multiplications,

$$2 * 0.156 = 0.312 \text{ so } a_1 = 0$$

$$2 * 0.312 = 0.624 \text{ so } a_2 = 0$$

$$2 * 0.624 = 1.248 \text{ so } a_3 = 1$$

$$2 * 0.248 = 0.496 \text{ so } a_4 = 0$$

$$2 * 0.496 = 0.992 \text{ so } a_5 = 0$$

$$2 * 0.992 = 1.984 \text{ so } a_6 = 1$$

we stop here because that is 6-bits.

$$0.156_{10} \Rightarrow 0.001001 \text{ (to 6-bits)}$$

The entire number then is,

$$27.156 \Rightarrow 11011.001001 \text{ (to 6-bits fractional) The actual fractional value is,}$$

$$0.001001 = 2^{-3} + 2^{-6} = 0.140625_{10}$$

3.5

a) complement of 1011 = 0100

$$\begin{array}{r} \\ + 1 \\ \hline 0101 \end{array}$$

(b) complement of 10101100 = 01010011

$$\begin{array}{r} \\ + 1 \\ \hline 01010100 \end{array}$$

3.6

Prove $\overline{A \bullet B} = \overline{A} + \overline{B}$

A	B	$\overline{A \bullet B}$	$\overline{A} + \overline{B}$
0	0	1	1
1	0	1	1
0	1	1	1
1	1	0	0

3.7

Let

$$F = A \bullet B + A \bullet (\overline{A \bullet B})$$

$$F = A \bullet B + A \bullet (\overline{A} + \overline{B})$$

$$F = A \bullet B + A \bullet \overline{A} + A \bullet \overline{B} \quad \text{but } A \bullet \overline{A} = 0$$

$$F = A \bullet (B + \overline{B}) \quad \text{but } B + \overline{B} = 1$$

$$F = A$$

3.8

For (a) we have an alarm when speed (S) is low, weight (W) is high and loading rate (R) is high,

$$\bar{S} \cdot W \cdot R$$

(b) speed is high and loading rate is low, $S \cdot \bar{R}$
 The combination is OR'ed to give,

$$A = \bar{S} \cdot W \cdot R + S \cdot \bar{R}$$

3.9

The equation above is implemented as follows,

(a) AND/OR logic

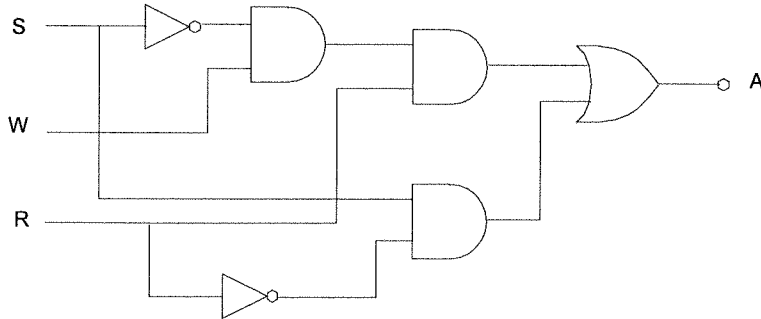

(b) in NAND/NOR logic we have,

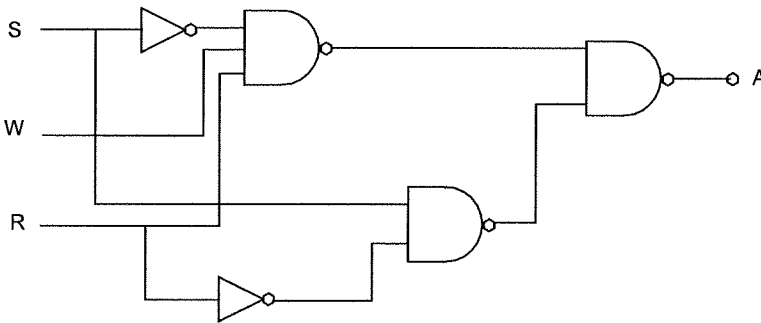

3.10

We simply translate the statements directly into Boolean expressions

a. OV: 1. $(QA + QB) \cdot \bar{QC} \cdot L \cdot \bar{P}$

2. $QA \cdot QB \cdot \bar{QC} \cdot \bar{P}$

thus,

$$OV = (QA + QB) \cdot \bar{QC} \cdot L \cdot \bar{P} + QA \cdot QB \cdot \bar{QC} \cdot \bar{P}$$

b. EP: 1. $\bar{QA} \cdot \bar{QB} \cdot \bar{L} \cdot QC$

2. $(\bar{QA} + \bar{QB}) \cdot QC \cdot P$

thus,

$$EP = \bar{QA} \cdot \bar{QB} \cdot \bar{L} \cdot QC + (\bar{QA} + \bar{QB}) \cdot QC \cdot P$$

3.11

The following logic circuits will provide the needed alarms.

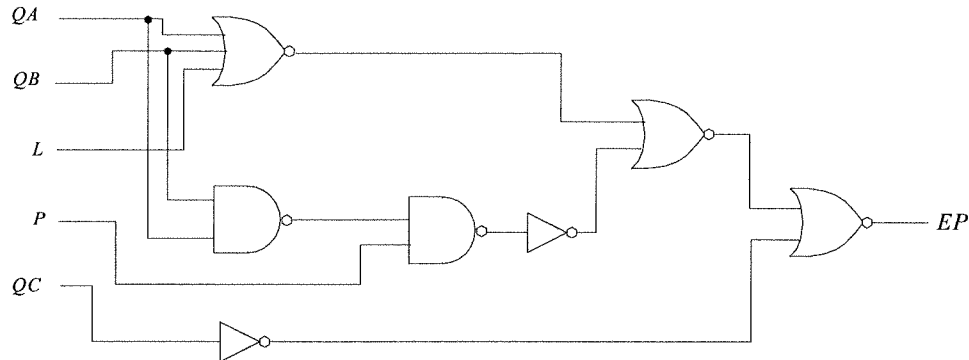
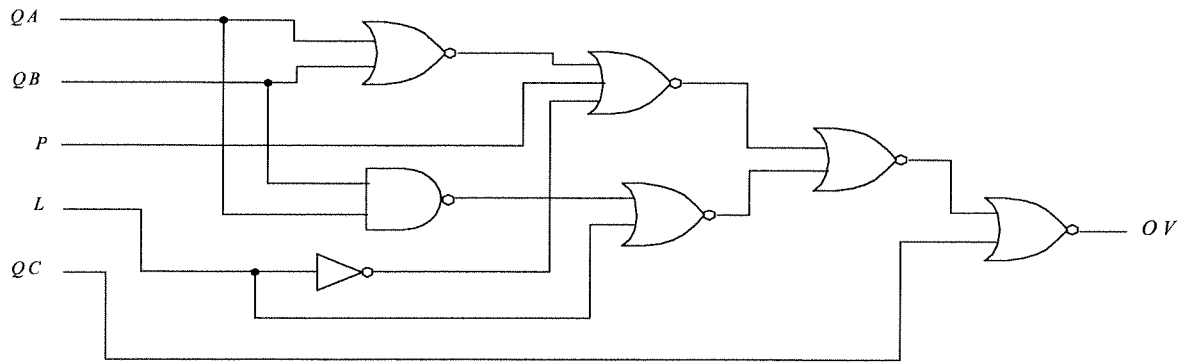

3.12

If the transfer function is $360 \mu\text{V}/^\circ\text{C}$ then a temperature of 530°C will result in an output voltage of,
 $V = (360 \times 10^{-6} \text{ V}/^\circ\text{C})(530^\circ\text{C})$

$$V = 0.1908 \text{ volts or } 0.191 \text{ to three significant figures.}$$

We can construct a divider from a +5 volt supply to obtain this required alarm voltage for the comparator. One possible circuit then is,

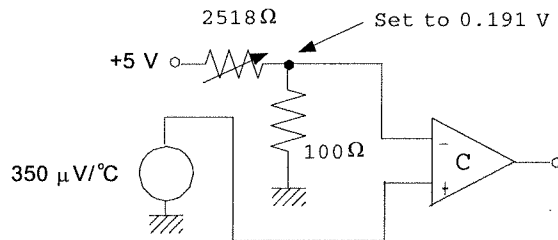

3.13

Using the transfer function of $0.04 \text{ V}/(\text{W}/\text{m}^2)$ we find the required comparator trigger voltage is,

$$V = (0.04 \text{ V}/(\text{W}/\text{m}^2))(30 \text{ W}/\text{m}^2)$$

$$V = 1.2 \text{ V}$$

and the noise provides a voltage fluctuation of,

$$\Delta V = (\pm 1.6 \text{ W}/\text{m}^2)(0.04 \text{ V}/(\text{W}/\text{m}^2))$$

$$\Delta V = \pm 64 \text{ mV}$$

We will provide a window of 128 mV about the trigger value of 1.2 V. This will be done by making the comparator go high when the signal plus noise is $(1.2 + .064) \text{ V} = 1.264 \text{ V}$ and return low when the output falls to $(1.2 - .064) \text{ V} = 1.136 \text{ V}$. Thus,

$$V_H = V_{ref} = 1.264 \text{ and}$$

$$V_L = V_{ref} - (R/R_f)V_0$$

$$1.136 = 1.264 - (R/R_f)(5 \text{ V})$$

$$(R/R_f) = 0.0256$$

Let's pick $R_f = 100 \text{ k}\Omega$ then $R = 2.56 \text{ k}\Omega$. The circuit of Figure 3.9 is used with a divider as in Figure 2.4 to develop the required reference voltage. The divider will have $V_s = 5.0 \text{ V}$, $R_1 = 295.6 \Omega$ and $R_2 = 100 \Omega$.

3.14

The hysteresis comparator is given in Figure 3.9. Dividers such as Figure 2.4 can be used to provide the required reference voltages. We pick a feedback resistor of $1 \text{ M}\Omega$ for all comparators. If the window is to be 1% of the reference value and the supply is to be five volts then the input resistance can be expressed as,

$$R = R_f \Delta V / V_0 = (1 \text{ M}\Omega)(0.01)V_{ref}/5 = 2000V_{ref} \Omega$$

We assume the dividers are derived from a five volt source with a 100Ω grounding resistor. Then the necessary resistance for the required reference is found from the divider equation as,

$$V_D = R_2 V_0 / (R_1 + R_2), \text{ but with } V_D = V_{ref}, V_0 = 5 \text{ V and } R_2 = 100 \Omega, \text{ we solve for } R_1 \text{ as,}$$

$$R_1 = 500 / V_{ref} - 100$$

So, we can now construct all the required values,

QA:	$V_{ref} = 0.15[55]^{1/2} = 1.11 \text{ V}$	$R = 2222 \Omega$	$R_1 = 350.5 \Omega$
QB:	$V_{ref} = 0.15[30]^{1/2} = 0.82 \text{ V}$	$R = 1640 \Omega$	$R_1 = 509.8 \Omega$
QC:	$V_{ref} = 0.15[100]^{1/2} = 1.5 \text{ V}$	$R = 3000 \Omega$	$R_1 = 233.3 \Omega$
P:	$V_{ref} = 20 / (120 + 20) = 0.14 \text{ V}$	$R = 280 \Omega$	$R_1 = 3471 \Omega$
L:	$V_{ref} = .05(3.6) = 0.18 \text{ V}$	$R = 360 \Omega$	$R_1 = 2678 \Omega$

All of the circuits have the following form with values from the table above.

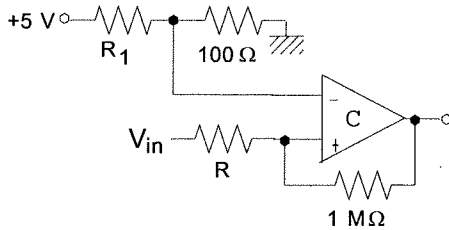

3.15

Let us define Boolean variables, TH and TL which will be high when the temperature exceeds 40 and $50 \text{ }^\circ\text{C}$ respectively. Similarly, QH and QL will be high when the flow exceeds 2 and 3 L/min . Now we can form a Boolean expression for the output, OUT ,

$$OUT = TL \cdot TH \cdot QL \cdot QH$$

Comparators can be used to generate the Boolean logic signals by assigning reference voltages found from the transfer functions of the sensors. The resistive sensor will be placed in a divider to convert the resistance to a voltage.

TH:	$R_{TH} = 1000e^{-.05(50-25)} = 286.5 \Omega$
TL:	$R_{TL} = 1000e^{-.05(40-25)} = 472.4 \Omega$
QH:	$V_{QH} = 5 / (3+5) = 0.625 \text{ V}$
QL:	$V_{QL} = 5 / (2+5) = 0.714 \text{ V}$

For the resistive sensor lets use a divider with a 500Ω resistor and use the five volt supply. We use the sensor in the upper resistor so the voltage will rise with increasing flow. Then the appropriate temperature reference voltages are:

$$V_{TH} = 5(500) / (500 + 286.5) = 3.18 \text{ V}$$

$$V_{TL} = 5(500) / (500 + 472.4) = 2.57 \text{ V}$$

Once the sensor signals are converted to Boolean by the comparator we use inverters and gates to implement the above Boolean equation. The result is given below.

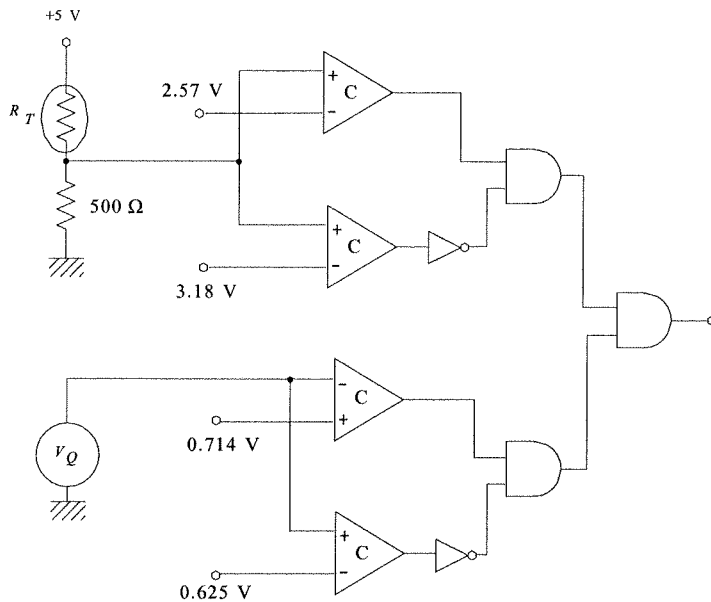

3.16

For the 6-bit DAC with a 100101_2 input and a 10 volt reference we have,

(a) the output is given by,

$$\begin{aligned} V_{out} &= 10(2^{-1} + 2^{-4} + 2^{-6}) \\ &= 10(0.578125) \\ &= 5.78125 \text{ V} \end{aligned}$$

(b) the resolution is $\Delta V = V_{ref}2^{-n}$ so,

$$\begin{aligned} \Delta V &= (10)(2^{-6}) \\ &= 0.15625 \text{ V} \end{aligned}$$

3.17

Well, we have $V_{max} = V_{ref}(2^{-1} + 2^{-2} + 2^{-3} + 2^{-4})$

$$8 = V_{ref}(0.5 + 0.25 + 0.125 + 0.0625) \text{ so } V_{ref} = 8.533 \text{ V}$$

3.18

(a) The minimum output of the 8-bit DAC is 0.0 volts so the minimum intensity is obviously 0.0 W/m^2 . For the maximum we note that the maximum output of the DAC is, $(255/256)5.00 = 4.9805 \text{ V}$. Thus the maximum intensity is,

$$45(4.9805)^{3/2} = 500 \text{ W/m}^2$$

(b) The intensity output for the given hex values is determined by finding the DAC voltage output and then using it in the transfer function of the source. Combining allows an equation for intensity versus the decimal equivalent of the hex number,

$$I_L = 45[(N/256)5.00]^{(3/2)}$$

HEX	N	Intensity (W/m^2)
1B	27	17.2
7A	122	165.5
9F	159	246.2
E5	229	425.7

(c) Of course since the DAC voltage is linearly related to the HEX input but the intensity is non-linearly related to the voltage we expect a nonlinear relation between HEX and intensity. Indeed, as the following graph shows, the relation is nonlinear.

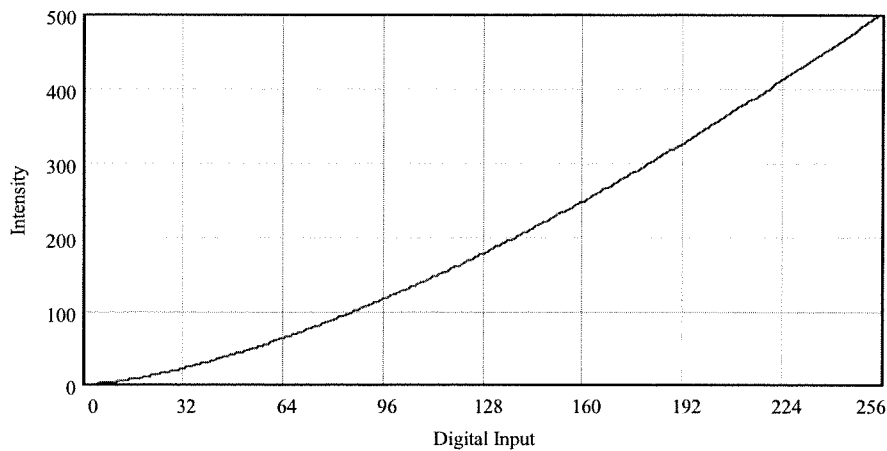

3.19

The relation between output voltage and digital input for a DAC is,

$$V_{out} = (N/2^n)V_{ref} - V_{ref}/2$$

so, for this case we have,

$$V_{out} = 10(N/4096) - 5$$

(a)	Digital	N	V_{out}
	4A6H	1190	-2.095
	02BH	43	-4.895
	D5DH	3421	3.352

(b) Solving for N for 4.74 volts, we find,

$$N = 4096(V_{out} + 5)/10 = (3989.504) = 3989 \text{ or F95H, since only integers are allowed. This}$$

will give an actual output of,

$$V_{out} = 10(3989/4096) - 5 = 4.738769531$$

this means an error of, 0.0026%!

(c) Well, if we look at it in terms of rms voltage we need only find out which bit toggles on a voltage change greater than 50 mV. Since $\Delta V = 10/4096 = 2.44 \text{ mV}$ we find,

bit 12	2.44 mV
bit 11	4.88
bit 10	9.76
bit 9	19.5
bit 8	39.1
bit 7	78.1

Thus bits 8 through 12 would be lost to noise. Suppose we considered peak to peak voltage for which the noise is $1.414(50) = 70.7 \text{ mV}$. Thus we would still lose bits 8 through 12. In either case we now have a 7-bit DAC.

3.20

(a) We must use a bipolar DAC with a 10 volt reference since that will provide the -5 to +5 volt swing on the output. A resolution of 10 mV means that the number of bits must be,

$$N = V_{ref}/\Delta V = 10/0.01 = 1000$$

This can be provided by a 10-bit DAC since there are 1024 states.

(b) The period is 2.5 ms and the output must count through 1024 states and then back to 0 in a total period. Thus the time between output changes will be,

$$\Delta t = 2.5 \text{ ms}/(2)(1024) = 1.22 \mu\text{s}$$

This is not going to be easy to do. The settling time of a typical DAC is often more than one microsecond and that does not include the software time. Nevertheless the software flowchart is a simple count up/count down sequence such as follows

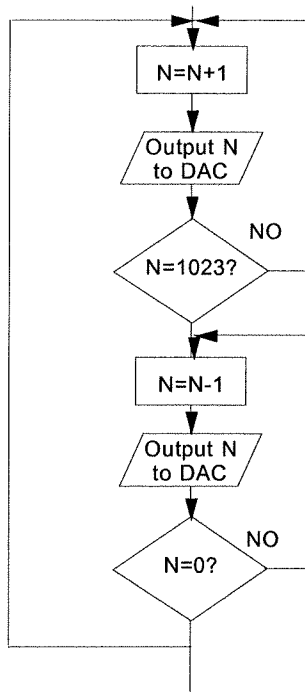

3.21

The ratio of input to reference is,

$$(3.797/10) = 0.3797$$

This fraction of the total counting states will provide the output as,

$$(0.3797)(2^8) = 97.2032 \text{ but since the output is the whole number part only it}$$

will be just 97, so

$$97 \approx 61H \text{ or } 01100001_2$$

This same output would be produced by input voltages which range from, $10(97/256) = 3.789$ to $10(98/256) = 3.828$

An output of $10110111_2 = 183_{10}$ so the input is at least $10(183/256) = 7.148$ volts but could be as high as

$$10(184/256) = 7.188 \text{ volts.}$$

3.22

The pressure transducer converts pressure to voltage according to,

$$666.6 \text{ mV/psi}$$

(a) We need a resolution of 0.5 psi with a 10 volt reference. This means a voltage resolution of $(0.5 \text{ psi})(666.6 \text{ mV/psi}) = 333.3 \text{ mV}$. So,

$$\Delta V = .3333 = V_{ref}2^{-n} = (10)2^{-n} \text{ or,}$$

$$0.0333 = 2^{-n}$$

taking logarithms,

$$\log(.03333) = -n \log(2)$$

$$-1.47716 = -0.30303n$$

$$n = 4.907$$

so we must use a 5-bit ADC.

(b) The maximum measureable pressure occurs for the output just changing to 11111_2 , so we can use

$$V_{max} = V_{ref}((2^{n-1}/2^n),$$

$$V_{max} = 10(31/32) = 9.6875 \text{ volts for a pressure of, } P_{max} = (9.6875 \text{ V})/(0.6666 \text{ V/psi}) = 14.53 \text{ psi}$$

3.23

For the bipolar ADC we have a relation,

$$\text{INT}(M) = [V + V_R/2]2^n/V_R$$

So, for 10 bits and a 10.0 volt reference we have, $INT(N) = (V + 5)1024/10 = (V + 5)102.4$

Now the given voltages are simply substituted,

V	INT(N)	HEX
-4.3	71	47
-0.66	444	1BC
2.4	757	2F5
4.8	1003	3EB

An output of 30BH means that $INT(N) = 779_{10}$. Using this in the equation above gives an input of,

$$V = INT(N)/102.4 - 5 = 779/102.4 - 5 = 2.607 \text{ volts.}$$

But the actual voltage input could be as high as

$$780/102.4 - 5 = 2.617 \text{ volts}$$

3.24

With no sample and hold the rate of change of input voltage is limited by the relation,

$$\frac{dV}{dt} \leq \frac{\Delta V}{\tau_c} = \frac{V_R}{\tau_c 2^n}$$

In this case the rate of change of input voltage is found by taking the derivative of the input,

$$\frac{d}{dt} [4(1 - e^{-t/\tau})] = \frac{4}{\tau} e^{-t/\tau} \text{ where } \tau \text{ is the time constant. The maximum value of the rate of}$$

change occurs at $t = 0$ so the condition on conversion becomes,

$$\frac{4}{\tau} \leq \frac{V_R}{\tau_c 2^n}$$

Solving for τ and putting in the given numbers provides the minimum value of τ :

$$\tau \geq \frac{4\tau_c 2^n}{V_R} = \frac{(4)(44 \times 10^{-6} \text{ s})(2^{10})}{5} = 36 \text{ ms}$$

Therefore the smallest time constant which can be measured to the full 10 bits is 36 ms.

3.25

The relation for ADC input signal rate, with no sample and hold, is given in the previous solution. If the input is a sinusoidal varying signal the derivative can be taken and the limitation expressed in terms of the frequency. This is given by Equation (3.19),

$$f \leq \frac{V_R}{2^{n+1} \pi \tau_c V_0} = \frac{5}{2^9 \pi (20 \times 10^{-6} \text{ s})(3)} = 51.8 \text{ Hz}$$

So, the largest frequency the signal which can be tracked to 8-bits is 51.8 Hz.

3.26

A model of the "ON" FET and capacitor shows that the system acts like a low pass filter of $R = 75 \Omega$ and $C = 0.47 \mu\text{F}$. The voltage appearing across the capacitor is down 3 dB at the critical frequency of the filter, $f_c = 1/2\pi RC$, so,

$$f_c = 1/(2\pi(75)(0.47 \times 10^{-6}))$$

$$f_c = 4515 \text{ Hz}$$

The limitation is the fact that the system cannot be used to sample signals with a frequency greater than about 4.5 kHz because of attenuation.

3.27

Ok, let's see what we have here. The diagram of Figure 3.22 illustrates the essential features of the problem for the sample and hold modes.

(a) There are two issues here; minimum time between samples and low-pass filter critical frequency. The critical frequency is,

$$f_c = \frac{1}{2\pi(R_x + R_{ON})C} = \frac{1}{2\pi(1 + 75)(0.0075 \times 10^{-6})} \approx 280 \text{ kHz}$$

Thus degradation of signal on the capacitor will not be a factor until the frequency exceeds 280 kHz. Now the maximum sampling frequency is determined by the minimum time between samples. This is the sum of aperture time, acquisition time and conversion time,

$$t_{min} = 5 \mu s + 0.8 \mu s + 35 \mu s = 40.8 \mu s$$

or, the maximum sampling frequency is

$$f_{max} = 24.5 \text{ kHz.}$$

Thus you can take a maximum of 24,500 samples per second assuming no processing time.

(b) The effect of droop is in terms of the rate of change of input voltage during the conversion process. Since this is exponential decay with a time constant given by Equation (3.21) we can express the maximum rate of change of input as the slope at $t = 0$. The effective time constant is given by Equation (3.21) as the parallel combination of R_{OFF} and R_{VF} and the capacitor, expression, $\tau_D = [R_{OFF}R_{VF}/(R_{OFF} + R_{VF})]C = [(20 \text{ M}\Omega)(7.5 \text{ M}\Omega)/(20 \text{ M}\Omega + 7.5 \text{ M}\Omega)](0.0075 \mu\text{F}) = 0.04 \text{ s}$. Thus,

$$\left(\frac{dV}{dt}\right)_{max} = -\frac{V_0}{\tau_D} = -\frac{5}{0.04} = -125 \text{ V/s}$$

The maximum allowable change for the ADC and with various numbers of bits is given by Equation (3.17) and in the problem above. We find

$n = 12$	max rate = 35 V/s	rate exceeds max
$n = 11$	= 70 V/s	"
$n = 10$	= 140 V/s	rate is less than max

Thus bits 11 and 12 are not valid even with the sample and hold because the droop exceeds the maximum allowable input change rate.

(c) The effect of the S/H ON resistance is given above as limiting the input frequency to 280 kHz due to low-pass filter roll-off.

3.28

A throughput of 100,000 samples per second means that there must be at least $10 \mu s$ between samples. If samples are taken every $5 \text{ ms} = 5000 \mu s$ then the time available for signal processing between samples is $4990 \mu s$.

3.29

Ok, if we want 37kHz to produce a full count then

$$(37000)T_c = 2^{10} - 1 = 1023$$

$$T_c = 27.65 \text{ ms}$$

At the other extreme of frequency the total count will be,

$$N_{4.6} = 27.65 \text{ ms}(4600 \text{ s}^{-1}) = 127$$

3.30

The circuit of Figure 3.25 and Equation (3.27) show how the frequency output of an LM331 depends upon the value of a capacitor, as well as other circuit components of course. In this case we will make the input voltage fixed and allow variations of capacity to change the frequency. From Equation (3.27) let's make, $R_s = 20 \text{ k}\Omega$, $R_L = 50 \text{ k}\Omega$ and $V_{in} = 5.1 \text{ volts}$ from a simple zener regulator. Then Equation (3.27) becomes,

$$f_{out} = \frac{20 \text{ k}\Omega}{50 \text{ k}\Omega} \frac{5.1}{2.09} \frac{1}{R_t C_t} = \frac{0.9761}{R_t C_t}$$

When $C_t = 0.04 \mu\text{F}$ we want the frequency to be 20 kHz, so this will determine the correct value for R_t ,

$$f_{04} = 20 \text{ kHz} = 0.9761/(0.04 \mu\text{F}R_t) \text{ or } R_t = 0.9761/[(0.04 \mu\text{F})(20 \text{ kHz})] = 1220 \Omega.$$

So the frequency at $0.26 \mu\text{F}$ is given by, $f_{26} = 0.9761/[90.26 \mu\text{F}(1220 \Omega)] = 3077 \text{ Hz}$.

For the 8-bit counter/converter we will need a count time of,

$$T_c = (2^8 - 1)/(20 \text{ kHz}) = 12.75 \text{ ms}$$

A plot of the frequency versus pressure is found by using the linearly specified relation between capacity and pressure and then the f_{out} equation above with $R_t = 1220 \Omega$. The capacity-pressure equation is found from the equation of a straight line, $C(p) = mp + C_0$. Since the capacity is given to be $0.04 \mu\text{F}$ when the pressure is zero, $C_0 = 0.04 \mu\text{F}$. The slope is just a change of $0.26 - 0.04 \mu\text{F} = 0.22 \mu\text{F}$ when the pressure changes by 100 kPa , so $m = 0.22 \mu\text{F}/100 \text{ kPa} = 0.0022 \mu\text{F/kPa}$

$$C(p) = 0.0022p + 0.04 \mu\text{F}$$

Thus we plot the equation,

$$f_{out} = 0.9761/[1220C(p)]$$

This is shown below. You can see the non-linearity because the pressure occurs in the denominator of the equation.

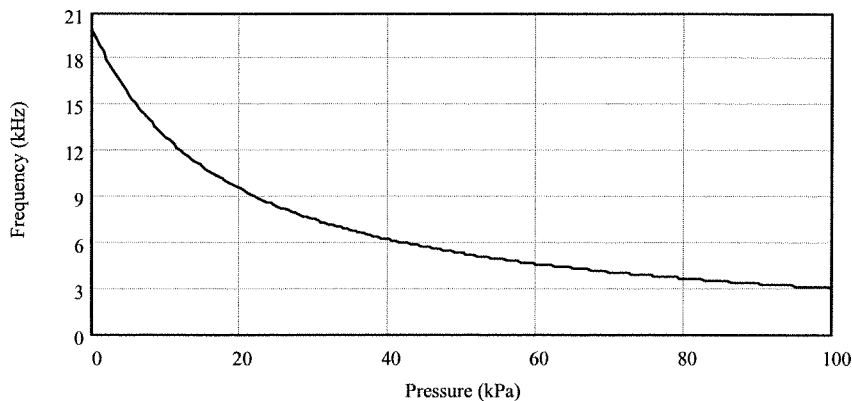

3.31

Ok, basically we need to get each indicated variable range to produce a voltage range of 0 V to 2.5 V. The resolution in each case is simply the variable range divided by 256 (i.e., 2^8 states).

1. Temperature: For 20°C to 100°C and 40 mV/°C the voltage generated by the sensor is 0.8 V to 4 V. This must become 0 to 2.5 volts. So,

$$V_{ADC} = mV_T + V_0 \text{ and we have,}$$

$$0 = 0.8m + V_0$$

$$2.5 = 4m + V_0$$

subtracting gives,

$$2.5 = 3.2m \text{ or } m = 0.78125$$

then, from the first equation,

$$V_0 = -0.8(.78125) = -0.625 \text{ V.}$$

Thus the required signal conditioning must provide,

$$V_{ADC} = 0.78125V_T - 0.625$$

The resolution is $\Delta T = (100-20)/256 = 0.3125$ °C/bit

2. Pressure: For 1 to 100 psi at 100 mV/psi the voltage generated by the sensor is 0.1 to 10 volts. This range must become 0 to 2.5 volts. This means we can subtract 0.1 and use a simple attenuator to get 2.5 V at 100 psi,

$$V_{ADC} = m(V_P - 0.1)$$

$$2.5 = m(100 - 0.1) \text{ or } m = 0.02525 \text{ or about } 0.0253 \text{ Thus,}$$

$$V_{ADC} = 0.0253(V_P - 0.1)$$

The resolution is given by $\Delta P = (100-1)/256 = 0.3867$ psi/bit

3. Flow: For 30 to 90 gal/min with 150 mV/(gal/min) the voltage range is 4.5 to 13.5 V which must become 0 to 2.5 V

so,

$$V_{ADC} = mV_F + V_0$$

$$0 = 4.5m + V_0 \quad 2.5 = 13.5m + V_0$$

subtracting gives,

$$m = 2.5/9 = 0.2778 \text{ and so, } V_0 = -4.5(0.2778) = -1.25 \text{ thus,}$$

$$V_{ADC} = 0.2778V_F - 1.25$$

The resolution is $\Delta F = (90 - 30)/256 = 0.234$ (gal/min)/bit

3.32

For the first case, temperature, we have

$$V_{ADC} = 0.781V_T - 0.625 \text{ which can be written,}$$

$$V_{ADC} = 0.781(V_T - 0.8).$$

This can be provided by a differential amplifier as shown below, with a gain (attenuation) of 0.781 and a constant input of 0.8 V.

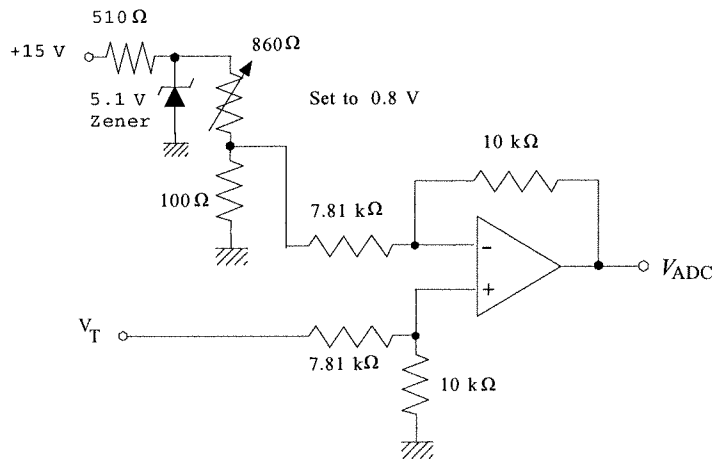

The second case, pressure, has an equation, $V_{ADC} = 0.253(V_P - 0.1)$. This can be provided by a differential amplifier with a gain (attenuation) of 0.253 and a constant input of 0.1 V.

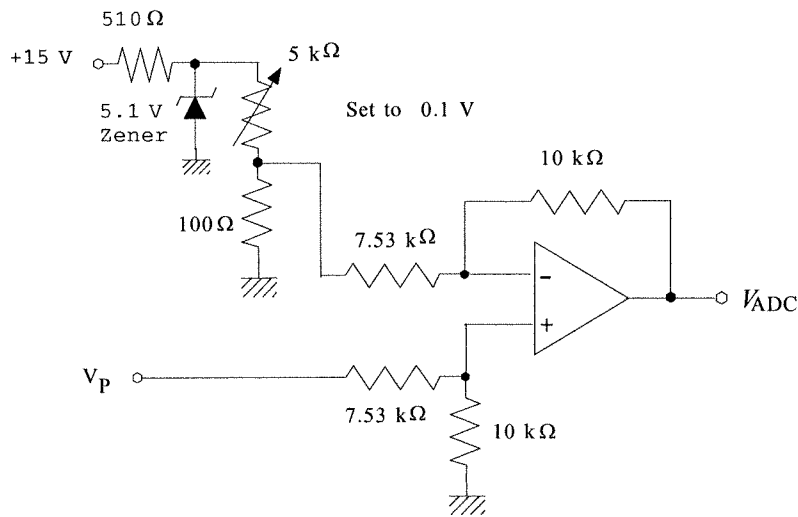

The third case has an equation, $V_{ADC} = 0.278V_F - 1.25 = 0.278(V_F - 4.5)$ This can again be provided by a differential amplifier with a gain (attenuation) of 0.278 and an constant input of 4.5 V.

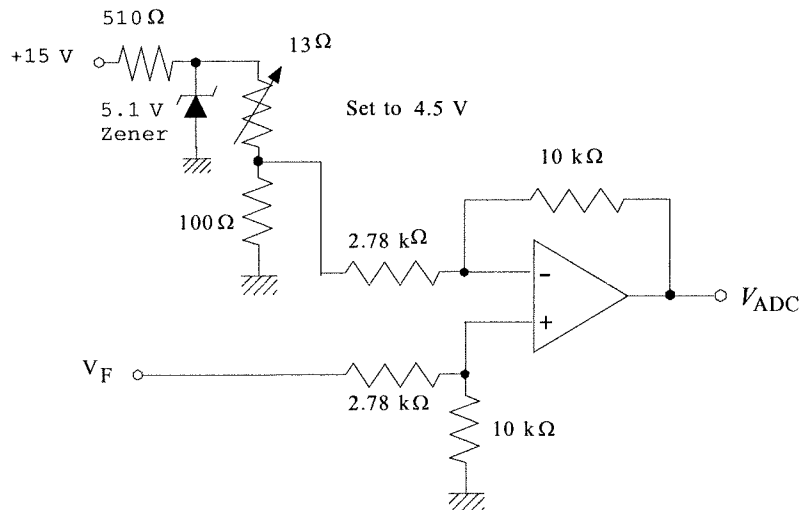

3.33

The total time for selecting, inputting and processing one channel is,

$$t = (3.1 + 33 + 450) \mu s = 486.1 \mu s$$

Therefore the total time for all 8 channels is,

$$T = 8t = 8(486.1 \mu s) = 3888.8 \mu s$$

This is the minimum time between samples of a particular channel.

3.34

The flow (Q) range is 30 m³/hr to 60 m³/hr and the sensor has a nonlinear transfer function of

$$V_Q = 0.0022Q^2.$$

Thus the voltage range for this flow range is

$$V_{Q1} = 0.0022(30)^2 = 1.98 \text{ volts}$$

$$V_{Q2} = 0.0022(60)^2 = 7.92 \text{ volts}$$

Lets select an ADC reference of 10.00 volts. Then the output will switch to FFH when the input voltage is given by, $V_Q(\text{FFH}) = 10(255/256) = 9.961 \text{ volts}$.

So, the signal conditioning must provide $V_{ADC} = 0$ when the input is 1.98 volts and $V_{ADC} = 9.961 \text{ volts}$ when the input is 7.92 volts. The signal conditioning equation can be easily shown to be,

$$V_{ADC} = 1.677(V_Q - 1.98)$$

This can be provided by a differential amplifier as shown below,

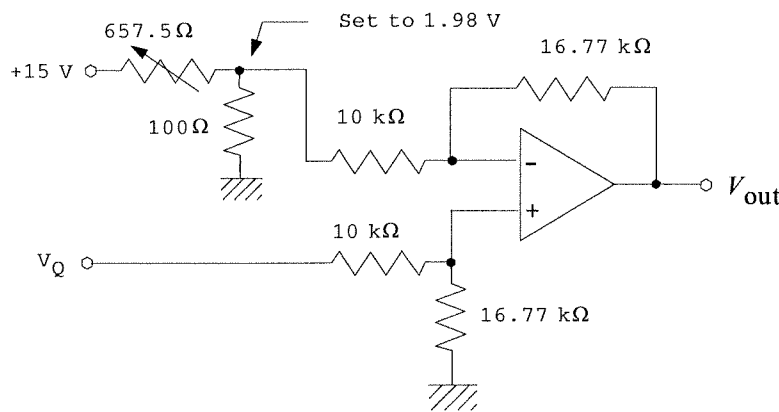

The resolution is the amount of flow change for a change of 1 LSB ADC output. Taking the derivative of the flow voltage equation gives,

$$\frac{dV_Q}{dQ} = 0.0044Q \quad (\text{volts per m}^3/\text{hr})$$

solving for the change in flow,

$$\Delta Q = \Delta V / (0.0044Q)$$

Of course we know that 1 LSB is changed by an input voltage change of

$\Delta V_{ADC} = V_{ref}2^{-8}$, and that the amplifier has a gain of 1.677, so the sensor output voltage change will be,

$$\Delta V = (10)2^{-8} / 1.677 = 0.0233 \text{ volts}$$

the flow change can be written,

$$\Delta Q = 0.0233 / (0.0044Q) = 5.295/Q \text{ m}^3/\text{hr for 1 LSB}$$

For 30 m³/hr this gives $\Delta Q = 0.177 \text{ m}^3/\text{hr for 1 LSB}$

for 60 m³/hr we find $\Delta Q = 0.088 \text{ m}^3/\text{hr for 1 LSB}$

The resolution is different because the response of the sensor is nonlinear.

3.35

Given an 8-bit ADC with an 8.00 volt reference.

(a) For an input of 3.4 volts we find the output as,

$$N_{10} = (3.4/8)256 = 108.8 \approx 108 \approx 6CH$$

For an input of 6.7 volts the output is,

$$N_{10} = (6.7/8)256 = 214.4 \approx 214 \approx D6H$$

(b) For B7H we first find that $B7H \Rightarrow 183_{10}$. Then,

$$V_{in} = 8(183/256) = 5.71875$$

but the output will stay B7H until the input changes by the voltage of one LSB, $\Delta V = (8)2^{-8} = 0.03125$ V, so the range is 5.71875 V to 5.75 V.

3.36

Where to start? Well, let's see, the output of the sensor will range from:

$$V_{s1} = (12 \text{ mV/mm})(-10 \text{ mm}) = -120 \text{ mV to } V_{s2} = +120 \text{ mV.}$$

This must be converted to 000H to FFFH. For the bipolar ADC with a 5 volt reference we have,

$$\text{INT}(N) = 2^{12}[V_{ADC} + 2.5]/5 = 4096[V_{ADC} + 2.5]/5 \text{ so,}$$

$$V_{ADC} = 5\text{INT}(N)/4096 - 2.5$$

When the position is -10 mm the output should be 000H so the input to the ADC should be $V_{ADC1} = 5 \times 0 - 2.5 = -2.5$ volts. When the position is +10 mm the output should be FFFH so that the input voltage must be, $V_{ADC2} = 5 \times 4095/4096 - 2.5 = 2.4988$ volts. From these we set up the signal conditioning equation,

$$V_{ADC} = mV_s$$

where there is no intercept.

So, $2.4988 = +0.120m$

Solving, we find, $m = 20.83$. This can be provided by a non-inverting amplifier with a gain of 20.83. The high input impedance of the amplifier will not cause any loading of the 2.5 kΩ sensor.

(a) Let us now consider the effect of noise with no filtering action. The amplifier will cause the 5 mV noise to show up as a 0.104 volts at the input of the ADC. Converting to peak voltage means multiplying by 1.414 so the peak output voltage will be 0.147 volts. Thus any signal from the sensor will have a value which oscillates ± 0.147 about the actual position generated value at 60 Hz. To see how many bits this represent we use the fact that the voltage at which the nth ADC bit toggles is given by, $V_n = 5(2^n/4096)$. Thus we find,

$$n = \log(4096V_n/5)/\log(2) = \log(4096 \times 0.147/5)/\log(2) = 6.9$$

Thus, of the 12 bits, the lower 6 are being toggled by noise!!! (and almost the 7th bit as well)

(b) Clearly some filtering action is necessary. Since the period of positional oscillation is 1.5 s this is a frequency of 0.667 Hz, which is about 90 times the noise frequency. Let's try a simple RC filter with extra gain to account for loss of positional signal. Suppose the noise is reduced by 99%. In this case the filter critical frequency is found from; $0.01 = [1 + (60/f_c)^2]^{-1/2}$ which results in $f_c = 0.6$ Hz.

The effect on the positional signal at 0.6667 Hz is,

$$(V_f/V_s) = [1 + (0.667/0.6)]^{-1/2} = 0.669$$

Thus some extra gain will be needed to restore the positional signal to properly interface to the ADC. In particular the amplifier gain must now be $20.83/0.669 = 31.14$.

Let's see how many bits the noise now represents. We start with 5 mV rms at 60 Hz. After the filter this becomes 5×10^{-5} volts (down 99%). But then after the amplifier the noise becomes 1.56 mV rms or 2.2 mV peak. This then represents, $n = \log(4096 \times 0.0022/5)/\log(2) = 0.8$. So the noise is not quite able to toggle the LSB.

The circuit for the signal conditioning system is shown below. Of course many other choices of component values could be used.

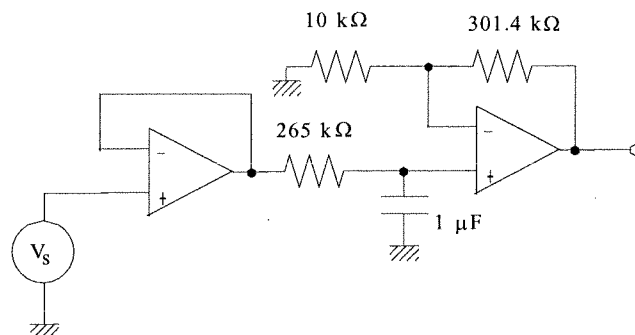

3.37

Of course there are many ways to provide a solution to this problem. The following shows one and how it is developed. To vary from 2.35 kΩ to 3.57 kΩ with a 1.25 Ω resolution will require,

$$(3570 - 2350)/1.25 = 976 \text{ states.}$$

Well 10 bits gives 1024 states so we will need a 10-bit ADC. In order to preserve the linearity we can use the sensor in the feedback of an inverting amplifier with a fixed, negative voltage input. The output of this first stage will be,

$$V_1 = -(R_s/R_1)V_{in}$$

It's somewhat arbitrary, so lets make $V_{in} = -5$ volts and pick $R_1 = 10$ k Ω . Then at the limits of resistance we will have an output voltage of,

$$V_{a1} = -(2.35 \text{ k}\Omega/10 \text{ k}\Omega)(-5 \text{ V}) = 1.175$$

$$V_{b2} = -(3.57 \text{ k}\Omega/10 \text{ k}\Omega)(-5 \text{ V}) = 1.785 \text{ V}$$

If we take the 10-bit ADC to have a 2.5 volt reference then the remaining signal conditioning must satisfy a linear transformation, $V_{ADC} = mV_1 + V_0$

$$\text{Then, } 0 = 1.175m + V_0$$

$$2.498 = 1.785m + V_0$$

Which provides, $V_0 = -1.175m$ and $m = 4.095$

The signal conditioning equation can be written,

$$V_{ADC} = 4.095(V_1 - 1.175)$$

This can be provided by a differential amplifier. The following schematic shows the op amp circuit which provides the overall signal conditioning.

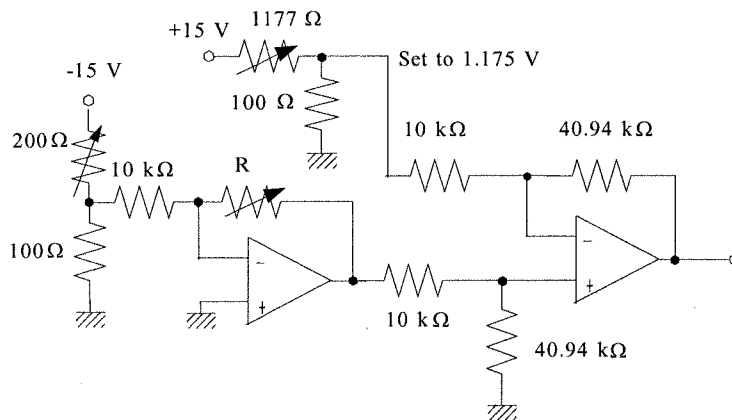

3.38

The following operations are required:

1. write $b_7 = 1$ to 301H to initialize the DAS
2. write $b_5 = 1$ to 300H to select channel 5
3. write $b_7 = 0$ AND $b_7 = 1$ to 301 to set up
4. write $b_7 = 0$ AND $b_0 = 0$ to 301 to issue a start convert
5. read 301H and test $b_7 = 0$ for EOC
6. read data from 300H
7. decrement the input number
8. write number to 302H

The flowchart is,

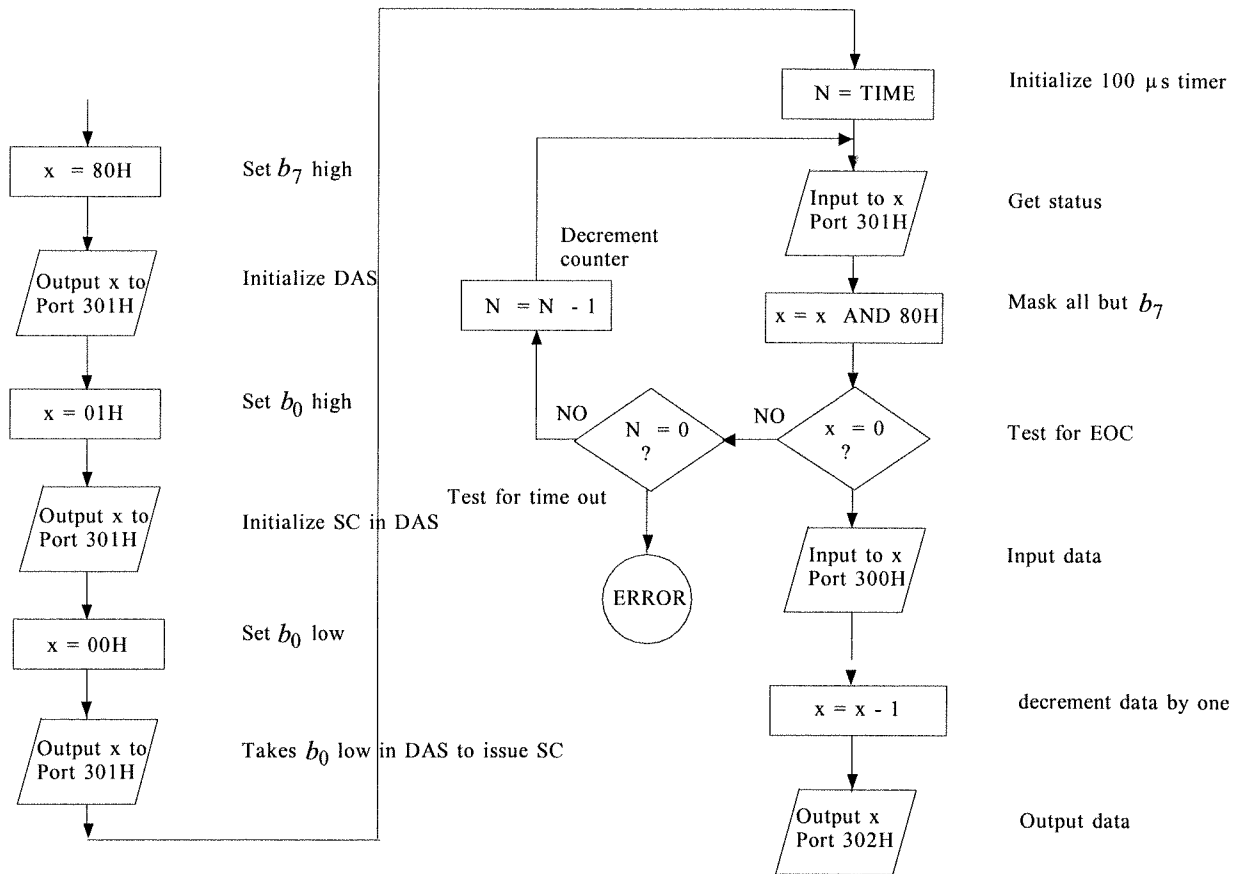

3.39

(a) For one channel we have the 25 μ s conversion time plus the 10 μ s acquisition time thus the total time between samples is, $t = 35 \mu$ s, which is a sample rate of 28.6 kHz

(b) For all eight channels we have the 35 μ s time for all channels so the total time is, $t_8 = 8(35 \mu$ s) = 280 μ s or a sample rate of 3.6 kHz.

3.40

For the flowchart we simply combine the data input routines given above and Example 3.32 with a product routine. The following are of special note:

In order to move the upper eight bits of the 16-bit product to the lower eight bits for output to the DAC we simply divide by 100H. This is equivalent to a right shift of eight bits. The lower eight bits are lost.

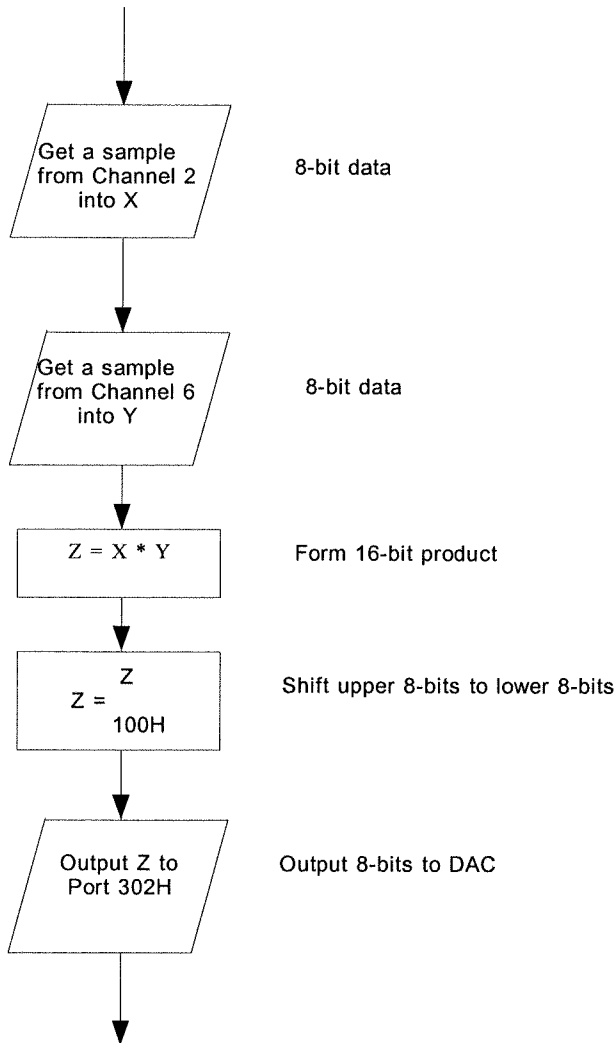

For the equation relating output to input we note the following:

$$\text{From the ADC equation: } X = (V_1/5 + 2.5)2^8$$

$$Y = (V_2/5 + 2.5)2^8$$

The multiplication gives, $Z = (V_1/5 + 2.5)(V_2/5 + 2.5)2^{16}$

The divisor, 100H, is simply 2^8 , so division by 100H gives,

$$Z = (V_1/5 + 2.5)(V_2/5 + 2.5)2^8$$

From the DAC equation we find,

$$V_{out} = (Z/2^8)10$$

substituting for Z, $V_{out} = 10(V_1/5 + 2.5)(V_2/5 + 2.5)$

3.41

The range of variation is 780 kPa - 30 kPa = 750 kPa and this must be resolved to 1.2 kPa. Therefore the minimum number of states is,

$$n = 750/1.2 = 625$$

Well, 8 bits provides 256, 9-bits provides 512 and 10 bits provides 1024 so it looks like we will have to use a 10 bit ADC.

3.42

Ok, a 2.2 s surge means an effective signal period of 2.2 s or a signal frequency of 0.454 Hz. Practical sampling frequency should be at least 10 times the signal frequency,

$$f_{samp} = 10f_{sig} = 4.54 \text{ Hz}$$

or about 0.22 s between samples. It takes 200 μ s to get a sample and t_{proc} seconds to process the sample. There are 10 stations, so to satisfy the 0.22 s rate means,

$10(200 \mu\text{s} + t_{proc}) = 0.22 \text{ s}$
 solving, $t_{proc} = 21.8 \text{ ms}$

3.43

The following diagram helps put the problem in perspective.

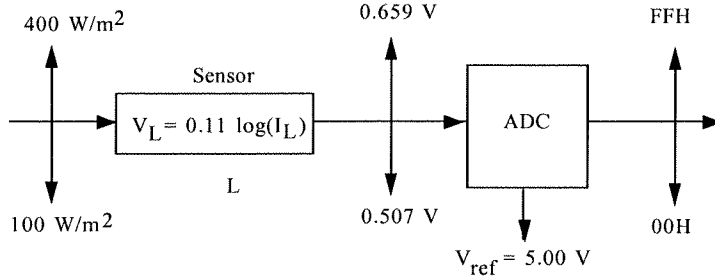

The requirement that 100 W/m^2 produce a 00H to 01H transition and 400 W/m^2 produce a FEH to FFH transition means the following conditions and equations must be satisfied by the signal conditioning:

(1) The 00H to 01H transition occurs for $V_{ADC} = 0.01953125$ or 0.0195 V to four fractional digits.

(2) The transition from FEH to FFH occurs for $V_{ADC} = 4.98046875$ or 4.9805 V .

From these the signal conditioning must satisfy,

$$V_{ADC} = mV_L + V_0$$

$$4.9805 = 0.6591m + V_0$$

$$0.0195 = 0.5066m + V_0$$

solving we find $m = 32.53$ and $V_0 = -16.46$. If this is placed in the form of a differential amplifier we have,

$$V_{ADC} = 32.53(V_L - 0.5066)$$

The following differential amplifier will provide the required input to the ADC.

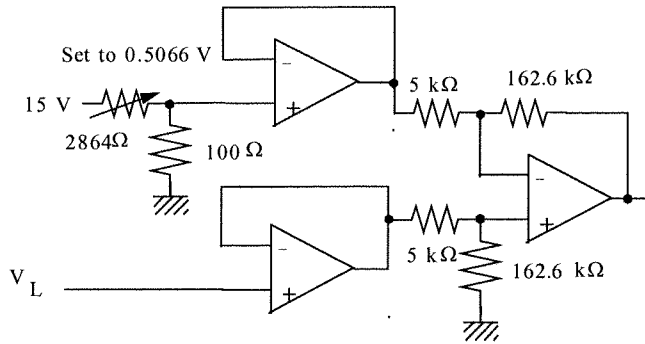

0

The software inputs a number N from the ADC. This can be converted back into V_{ADC} and then to V_L and I_L if we assume a higher level language. Thus

$$V_{ADC} = 5 * N / 256$$

$$V_L = V_{ADC} / 32.53 + 0.506$$

$$I_L = \text{EXP}(V_L / 0.11)$$

3.44

The input to the program is the direct TC voltage. We may assume that some data processing software converts the actual digital input into the appropriate TC voltage. The correction voltage will be the voltage for 20°C from the tables with a 0°C reference. This is,

$$V_{corr} = 0.80 \text{ mV}$$

Initial inputs will thus have this correction added. The temperature is found from a look-up table and interpolation routine. We assume the table is arranged so that $V(I)$ and $T(I)$ are the Ith entries of voltage and corresponding temperature. The difference between any $T(I)$ and $T(I+1)$ is 5°C . The following flowchart shows the essential features of the algorithm.

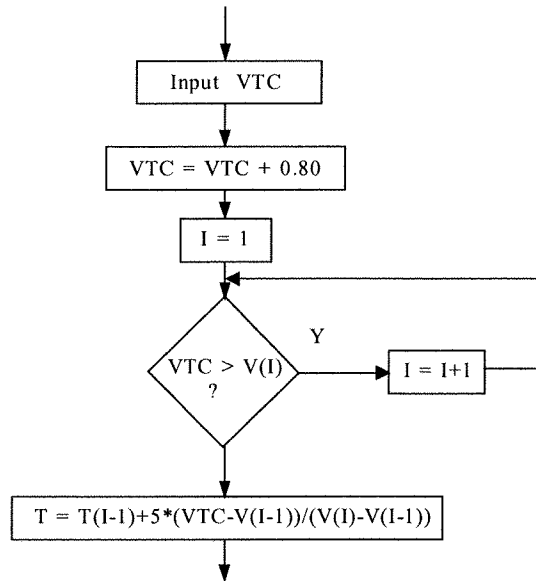

3.45

The strain gauge can provide the strain from the resistance change by,

$$S = (\Delta l/l) = (1/GF)(\Delta R/R) = (1/2.05)(\Delta R/120)$$

$$S = \Delta R / ((2.05)(120))$$

The change in resistance can be determined from the off-null voltage of the bridge.

Assume the bridge has the form,

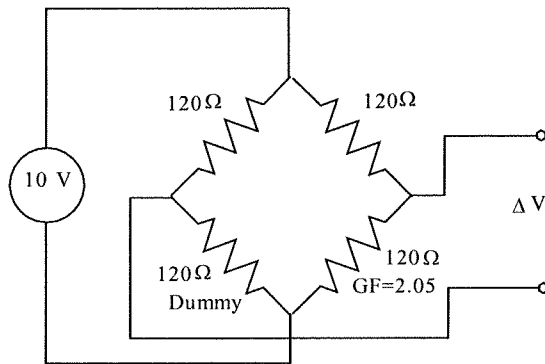

Then the off-null voltage is given by,

$$\Delta V = 10 \left[\frac{120}{120 + 120} - \frac{R}{120 + R} \right]$$

solving for R ,

$$R = 120 \frac{(0.5 - \Delta V/10)}{(0.5 + \Delta V/10)}$$

or, factoring a 10 and noting that $R = 120 + \Delta R$

$$\Delta R = -120 \frac{2\Delta V}{5 + \Delta V}$$

Now, using the equation for strain, S , given above,

$$S = - \frac{2\Delta V}{2.05(5 + \Delta V)} = - \frac{0.9756\Delta V}{(5 + \Delta V)}$$

So in the program the appropriate equation for the strain will be,

$$\text{STRAIN} = \frac{0.9756 * \text{DELTA V}}{(5 + \text{DELTA V})}$$

Supplementary Problems

S3.1

We start by noting that there are four flow values involved the alarm conditions and so we will need four comparators to pick out these values. We can find the comparator reference voltages for these four conditions from the sensor transfer function,

$$\begin{aligned} \text{For 6 kg/hr} \quad V_6 &= 0.45[6 + 9]^{1/2} = 1.74 \text{ V} \\ \text{For 5.1 kg/hr} \quad V_{5.1} &= 0.45[5.1 + 9]^{1/2} = 1.69 \text{ V} \\ \text{For 4 kg/hr} \quad V_4 &= 0.45[4 + 9]^{1/2} = 1.62 \text{ V} \\ \text{For 2.9 kg/hr} \quad V_{2.9} &= 0.45[2.9 + 9]^{1/2} = 1.55 \text{ V} \end{aligned}$$

We will wire the comparators so that they go high if the flow condition is met, so, for example, if the flow exceeds 2.9 kg/hr then that comparator is high.

For the first alarm condition, we immediately think of a flip-flop which will be set when the flow exceeds 6 kg/hr and reset if the flow drops below 4 kg/hr. Now if the flow drops below 6 kg/hr and then above again without dropping below 4 kg/hr an alarm should be issued. So we need another flip-flop to record when the flow drops below 6 kg/hr. Then if both flip-flops are set AND the flow exceeds 6 kg/hr again the alarm is issued. A third flip-flop is used to capture this event as shown in the figure that follows. If the 4 kg/hr comparator goes low (flow < 4 kg/hr) all flip-flops are reset.

For the second alarm condition we need a 2-second timer that is started when the flow exceeds 5.1 kg/hr. Then if the flow drops below 2.9 kg/hr before the timer has finished an alarm flip-flop should be set. So the 5.1 kg/hr sets a flip-flop and starts the timer (MV is high for 2 seconds). If the timer times out the flip-flop is reset. If the 2.9 kg/hr comparator goes low (flow < 2.9 kg/hr) within 2 sec the alarm is generated. This is shown below.

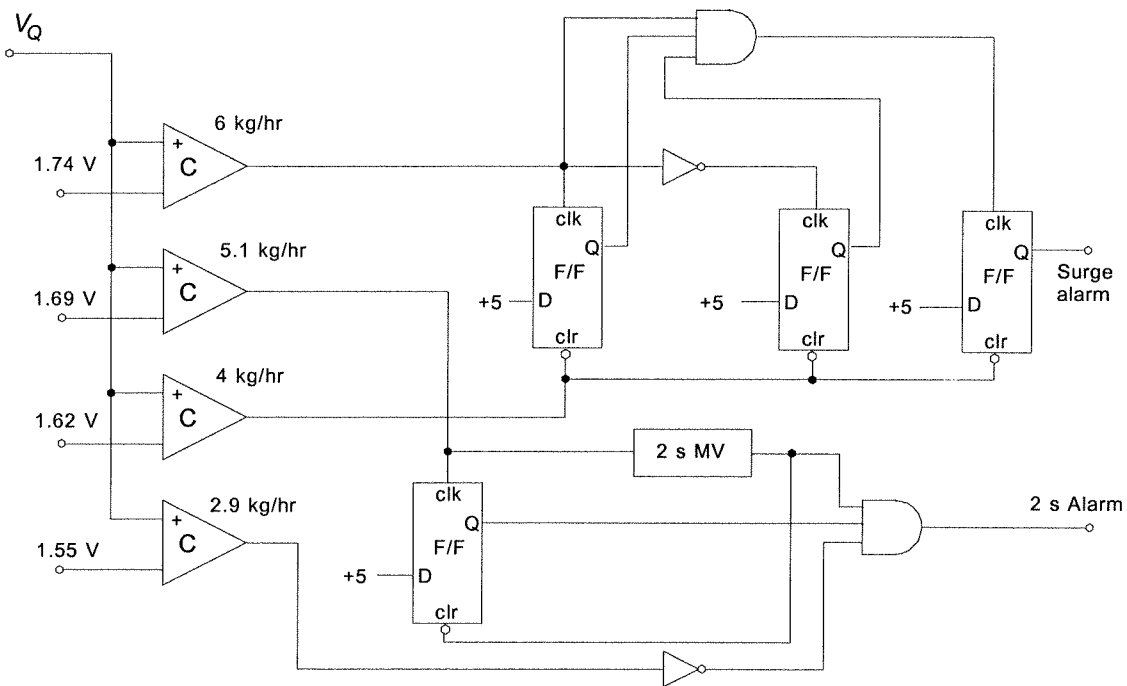

S3.2

(a) Ok, first let's see how many bits the ADC will need. If the range is 70 kPa and the required resolution is at least 0.2 kPa then that is, $70/0.2 = 350$ states. So 8-bits won't do because it provides only 256 states but 9-bits will work since this gives 512 states. The actual resolution will be $\Delta p = 70/512 = 0.1367$ kPa.

From the transfer function of the sensor we can now determine how many volts this pressure resolution results in, $\Delta V = (2.5 \text{ mV/kPa})(0.1367 \text{ kPa}) = 0.3418 \text{ mV}$. So the LSB of the ADC will be triggered by a change of 0.3418 mV. It makes sense that we must then depress the noise so that it cannot also trigger this LSB. From that we find the required voltage reduction of a low pass filter at 60 Hz,

$$\left| \frac{V_{out}}{V_{in}} \right|_{60} = \frac{0.3418}{55} = 0.0062 = \frac{1}{\sqrt{1+(60/f_c)^2}}$$

so, inverting and squaring,

$$26014 = 1 + (60/f_c)^2 \quad \text{and} \quad (60/f_c) = 161.3 \quad \text{giving} \quad f_c = 0.37 \text{ Hz}$$

Therefore we need an RC low pass filter with a critical frequency of 0.37 Hz. The values of resistor and capacitor are found from, $RC = 1/(2\pi f_c) = 0.43 \text{ s}$

Let's try $C = 10 \mu\text{F}$, then $R = 43 \text{ k}\Omega$. That seems ok.

Let's use a 9-bit ADC with a 5.0 volt reference (probably really a 10-bit but we can still design around the 9). Full scale will occur with a voltage of $5.0 - 5/2^9 = 4.99 \text{ V}$. So we need an amplifier with a gain of,

$$G = \frac{4.99}{0.175} = 28.5$$

To avoid loading problems we will use a non-inverting amplifier. The full circuit is shown below

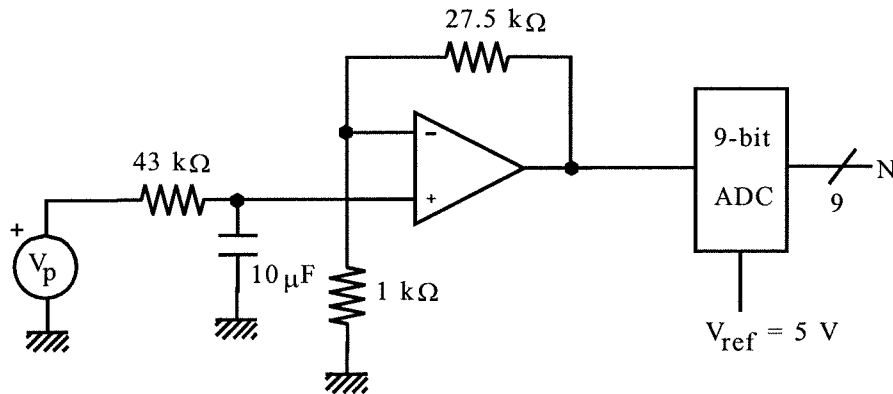

(b) The filter presents a first-order time delay on any sudden change of input voltage. Regardless of the conversion time of the ADC, it makes no sense to take a reading from the system, following a sudden change, until about 5 filter time constants have lapsed. We already found the time constant above as 0.43 seconds. So we must wait a time of $t_{wait} = 5\tau = 5(0.43 \text{ s}) = 2.15 \text{ seconds}$ before readings will be valid.

S3.3

(a) The sensor transfer function is 0.02 Volts per °C. The differential amplifier has a 0.28 volt input on the inverting terminal and a gain of 12.5. Thus the input to the ADC is given by the equation,

$$V_{ADC} = 12.5(0.02T - 0.28)$$

The the ADC output will be $N = (V_{ADC}/2.0)2^8$

T	V_{ADC}	N
14	0.0	0
19	1.25	160(A0H)
22	2.00	255(FFH)

(b) Heater voltage varies from 0 to 5 for 0 to 100% heat, so for a particular percentage P of heat the required voltage is, $V = 5P/100$. The DAC input to produce this voltage will be $N = (V/5)2^8$

P	V	N
0	0	0
38	1.9	97(61H)
70	3.5	179(B3H)
100	5	255(FFH)

(c) The following flow chart shows the required program actions,

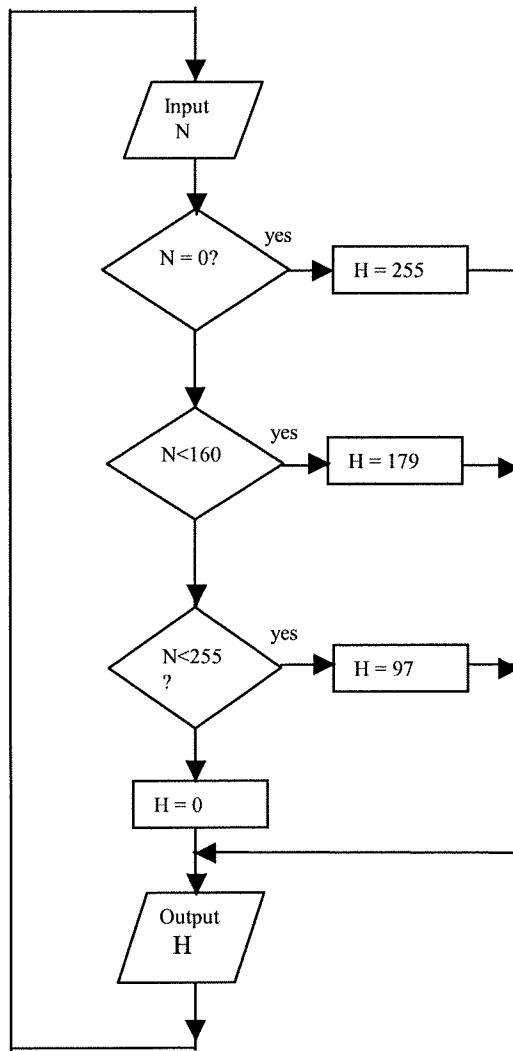

CHAPTER 4

4.1

Given 453.1 °R:

(a) For conversion to K: $T = (5/9)(453.1 \text{ °R})$

$$T = 251.7 \text{ K}$$

(b) For conversion to °C: $T = 251.7 - 273.15$

$$T = -21.45 \text{ °C}$$

(c) For conversion to °F: $T = 453.1 - 459.6$

$$T = -6.5 \text{ °F}$$

4.2

Given -222 °F:

(a) To °C: $T = (5/9)(-222 - 32) = (5/9)(-254)$

$$T = -141.1 \text{ °C}$$

(b) To °R: $T = -222 + 459.6$

$$T = 237.6 \text{ °R}$$

(c) To K: $T = (5/9)(237.6)$

$$T = 132 \text{ K}$$

4.3

$T = 150 \text{ °C}$ becomes,

$$150 + 273.15 = 423.15 \text{ K}$$

$$9(150)/5 + 32 = 302 \text{ °F}$$

4.4

The °C and °F are related by a factor of (5/9), so,

$$\Delta T = 33.4 \text{ °F} = (5/9)(33.4)$$

$$= 18.6 \text{ °C}$$

4.5

The relations between temperature, energy and speed are,

$$W = (3/2)kT \quad k = 1.38 \times 10^{-23} \text{ J/K}$$

$$W = (1/2)mv^2 \quad m = 3.3 \times 10^{-27} \text{ kg}$$

so, $T = 500 + 273.15 = 773.15 \text{ K}$

$$W = (3/2)(1.38 \times 10^{-23} \text{ J/K})(773.15 \text{ K})$$

$$W = 1.6 \times 10^{-20} \text{ J}$$

then,

$$v = [2W/m]^{1/2}$$

$$v = [2(1.6 \times 10^{-20})/(3.3 \times 10^{-27})]^{1/2}$$

$$v = 3114.4 \text{ m/s !!}$$

in ft/s this is,

$$v = (3114.4 \text{ m/s})/(0.3048 \text{ m/ft}) = 10217.8 \text{ ft/s}$$

4.6

We simply convert the temperature limits into °F;

$$(9/5)(350 \text{ °C}) + 32 = 550 \text{ °F}$$

$$(9/5)(550 \text{ °C}) + 32 = 1022 \text{ °F}$$

4.7

$$R(T) = R(T_0)[1 + \alpha(T - T_0)]$$

$$R(25 \text{ °C}) = 106[1 + 0.004(25 - 20)] = 108.12 \text{ } \Omega$$

4.8

The circuit is

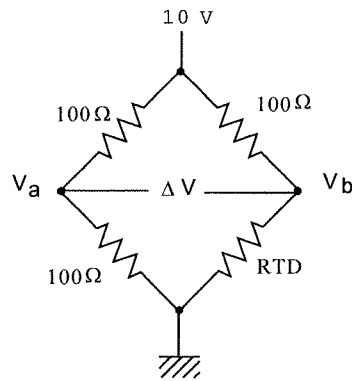

Note that the bridge is not nulled at 20°C since the RTD is 106 Ω at that temperature, not 100 Ω. We find the off-null voltage at 20 °C and then the voltage at 21 °C. The difference will be the required detector resolution for a 1°C change.

$$\Delta V(20) = 10[100/200 - 106/206] = -0.1456 \text{ V}$$

the resistance at 21 °C is,

$$R(21) = 106[1 + 0.004(21 - 20)] = 106.424 \Omega$$

so the off-null voltage is,

$$\Delta V = 10[100/200 - 106.424/206.424] = -.1556 \text{ V}$$

Thus the difference, which is the required resolution, is

$$V_R = -.1456 + .1556 = .01 \text{ V or } 10 \text{ mV}$$

4.9

(a) For the linear approximation we use Eq. (4-11) to find the slope, and then the R vs T relation is,

$$R(T) = R(T_0)[1 + \alpha_0(T - T_0)]$$

so,

$$\alpha_0 = \frac{1}{R(T_0)} \frac{R_2 - R_1}{T_2 - T_1} \alpha_0$$

here, $T_0 = 115$ °C, $T_1 = 100$ °C, $T_2 = 130$ °C and the corresponding resistances are,

$$R_0 = 589.48 \Omega, R_1 = 573.40 \Omega \text{ and } R_2 = 605.52 \Omega \text{ so,}$$

$$\alpha_0 = (1/589.48)[(605.52 - 573.40)/(130 - 100)]$$

$$\alpha_0 = 0.0018 / ^\circ\text{C}$$

$$R(T) = 589.48[1 + 0.0018(T - 115)]$$

(b) The quadratic approximation is given by Eq. (4-12),

$$R(T) = R(T_0)[1 + \alpha_1\Delta T + \alpha_2(\Delta T)^2]$$

$$\text{where } \Delta T = T - T_0$$

Clearly $T_0 = 115$ °C and therefore $R(T_0) = 589.48 \Omega$ which leaves two unknowns. These are found by forming simultaneous equations so that the approximation equation is exact at 100 °C and 130 °C.

At 100 °C, $\Delta T = 100 - 115 = -15$ and at 130 °C, $\Delta T = +15$, so the two equations are,

$$573.40 = 589.48[1 - 15\alpha_1 + 225\alpha_2]$$

$$605.52 = 589.48[1 + 15\alpha_1 + 225\alpha_2]$$

or,

$$-15\alpha_1 + 225\alpha_2 = -0.027278$$

$$15\alpha_1 + 225\alpha_2 = 0.027278$$

these can easily solved for the two unknowns to give,

$$\alpha_1 = 1.82 \times 10^{-3} / ^\circ\text{C}$$

$$\alpha_2 = -1.51 \times 10^{-7} / (^\circ\text{C})^2$$

so,

$$R(T) = 589.48[1 + 0.00182\Delta T - 1.51 \times 10^{-7}(\Delta T)^2]$$

The table provides a resistance of 578.77 Ω at 105°C. The linear approximation gives,

$$R_L = 589.48[1 + 0.0018(105 - 115)] = 578.87 \Omega$$

for an error of -.017%. For the quadratic approximation the result is ,

$$R_Q = 589.48[1 + 0.00182\Delta T - 1.51 \times 10^{-7}\Delta T^2] = 578.74 \Omega \text{ or an error of } 0.005\%$$

4.10

If in a bath at a temperature of 100°C the resistance of the RTD should be,

$$R(100^\circ\text{C}) = 106[1 + 0.004(100 - 20)] \\ = 139.92 \Omega$$

However, if there are 8 mA through the sensor then the self heating will cause a temperature rise from the power dissipation. The power dissipated is,

$$P = I^2R = (0.008)^2 139.92 \\ = 8.95 \text{ mW}$$

Thus the temperature rise will be,

$$\Delta T = P/P_D = 8.95 \text{ mW}/25 \text{ mW}/^\circ\text{C} = 0.36^\circ\text{C}$$

So the resistance will be,

$$R(100^\circ\text{C}) + \Delta R = 106[1 + 0.004(100.36 - 20)] = 140.1 \Omega$$

If you didn't know about the self-heating temperature rise you would think the temperature was 100.36°C.

4.11

At 20 °C the thermistor resistance is 100 Ω, so the bridge is nulled. At 21 °C the resistance drops by

$$\Delta R = (-.1)(100 \Omega) = - 10 \Omega$$

so that it is now 90 Ω. The required resolution is then just the off-null voltage for this resistance,

$$\Delta V = 10[0.5 - 90/190] = 263.2 \text{ mV}$$

4-12

If the self heating is to be 0.1 °C then the power which can be dissipated by the thermistor is given by,

$$P = P_D \Delta T = (5 \text{ mW}/^\circ\text{C})(0.1^\circ\text{C}) = 500 \mu\text{W}$$

This means a nominal thermistor current of,

$$I = [P/R]^{1/2} = [(5 \times 10^{-4})/(3.5 \times 10^3)]^{1/2} = 378 \mu\text{A}$$

The divider resistor must therefore be given by,

$$I = V/(R + R_{TH})$$

or

$$378 \times 10^{-6} = 10/(R + 3500)$$

from which $R = 22.955 \text{ k}\Omega \approx 23 \text{ k}\Omega$

With a slope of -10%/°C, the resistances are,

$$3.5 \text{ k}\Omega @ 20^\circ\text{C},$$

$$3.15 \text{ k}\Omega @ 21^\circ\text{C}$$

$$\text{and } 3.85 \text{ k}\Omega @ 19^\circ\text{C}$$

The divider voltages are found from,

$$V_D = 10R_{TH}/(23 \text{ k}\Omega + R_{TH})$$

so we easily find,

$$V_D = 1.32 \text{ V} @ 20^\circ\text{C}$$

$$= 1.20 \text{ V} @ 21^\circ\text{C}$$

$$= 1.43 \text{ V} @ 19^\circ\text{C}$$

4.13

The relation between output voltage and resistance for this inverting amplifier is simply given by,

$$V_{out} = - (6 \text{ k}\Omega/R_{TH})(-1 \text{ V})$$

or

$$V_{out} = 6/R_{TH} \quad (\text{for } R_{TH} \text{ in k}\Omega)$$

The plot is shown below and is clearly not linear. The maximum self-heating occurs at 80 °C where the resistance is approximately 500 Ω and the current will be a maximum. Thus, using $P = V^2/R$

$$\Delta T = P/P_D = (-1)^2/(500 \times .005) = 0.4^\circ\text{C}$$

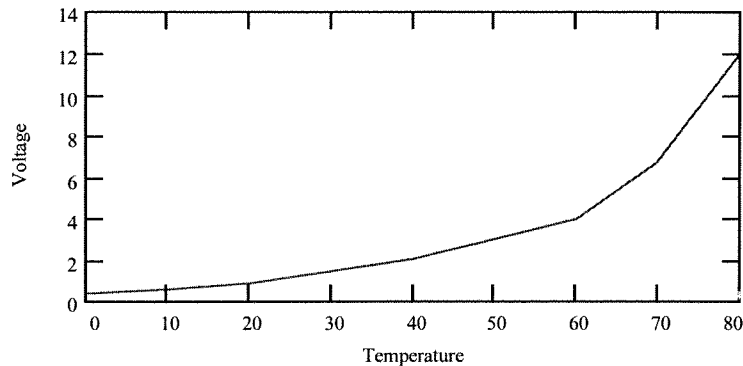

4.14

A Type J TC with a 0 °C reference measures 22.5 mV. The tables in the back of the book can be used directly since they are for the same reference. 22.5 mV lies between 22.4 mV at 410 °C and 22.68 mV at 415 °C. We interpolate then,

$$T = T_L + \frac{(T_H - T_L)}{(V_H - V_L)} (V - V_L)$$

$$T = 410 + \frac{(415 - 410)}{(22.68 - 22.4)} (22.5 - 22.4)$$

$$T = 411.78 \text{ } ^\circ\text{C}$$

4.15

A Type S TC with a 21 °C reference measures 12.120 mV. Since the reference is different than the tables a correction to this voltage must be applied. The voltage from the tables for 21 °C is between 0.113 mV at 20 °C and 0.143 mV at 25 °C. Interpolating gives:

$$V_{ref} = 0.113 + \frac{(0.143 - 0.113)}{(25 - 20)} (21 - 20)$$

$$V_{ref} = 0.119 \text{ mV which is the correction.}$$

We expect the table voltage to be larger in magnitude since 0 °C is further from the measurement temperature than 21 °C, so we add this correction,

$$V_c = 12.120 + 0.119 = 12.239 \text{ mV}$$

This lies between 1225 °C and 1230 °C. Interpolating,

$$T = 1225 + \frac{(1230 - 1225)}{(12.296 - 12.236)} (12.239 - 12.236)$$

$$T = 1225.25 \text{ } ^\circ\text{C}$$

4.16

A Type J TC with a -10°C reference is used to measure 500 °C. We can find the voltage which would be produced by a Type J TC with a 0 °C reference from the tables in the book. The result is,

$$V = 27.39 \text{ mV (0 } ^\circ\text{C reference)}$$

We would expect the actual TC to give a larger magnitude voltage since the reference (-10 °C) is more different from 500 °C than 0 °C. Thus we find the voltage of -10 °C and use it to make the table value larger,

$$V_{ref} = -0.5 \text{ mV}$$

So,

$$V_{measure} = 27.39 + 0.5 = 27.89 \text{ mV}$$

4.17

The measurement can be modeled as follows:

(a) The voltage for 300°C with a 0°C reference can be read directly from the tables as 12.21 mV.

(b) The measurement can be modeled as:

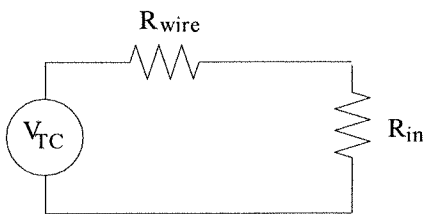

Where the thermocouple has been modeled as a source of voltage 12.21 mV and the lead wires have been modeled as a series resistance, $R_{wire} = 2(1000 \text{ ft})(0.01 \Omega/\text{ft}) = 20 \Omega$. The voltage measuring system has an effective input resistance, R_{in} . The error voltage is the voltage dropped across R_{wire} , which can be expressed as a percentage of the actual voltage, V_{TC} ,

$$\frac{\Delta V}{V_{TC}} \times 100 = \frac{IR_{wire}}{V_{TC}} = \frac{1}{V_{TC}} \frac{V_{TC}}{R_{in} + R_{wire}} R_{wire}$$

simplifying, we get,

$$0.002 = 20/(R_{in} + 20)$$

$$R_{in} = (20 - .04)/.002 = 9980 \Omega$$

4.18

Well, a type K TC at 700°C produces 29.14 mV with a 0°C reference. A temperature of 20°C (\approx room temperature) will produce 0.80 mV. Thus a single type K with a 20°C reference will produce 29.14 - 0.80 = 28.34 mV at 700°C. To get an output voltage of 1.5 volts will require, $1.5/0.02834 = 52.9$ or about 53 thermocouples in series.

4.19

We need to find the thermal expansion of the rod.

$$L = L_0(1 + \gamma\Delta T)$$

or,

$$\Delta L = L_0\gamma\Delta T = (0.1 \text{ m})(16.6 \times 10^{-6}/^\circ\text{C})(150 - 20)$$

$$\Delta L = 2.158 \times 10^{-4} \text{ m} \approx 0.22 \text{ mm}$$

4.20

From the gas laws we know that, $(p_1/T_1) = (p_2/T_2)$ thus,

$$T_2 = (p_2/p_1)T_1$$

where the temperature must be in absolute units, kelvin (K),

$$T_2 = (215/125)273.15 = 469.8 \text{ K} \quad \text{or,}$$

$$T_2 = 469.8 - 273.15 = 196.7 \text{ }^\circ\text{C}$$

4.21

The pressure range for methyl chloride between 70 °F and 200 °F is found from the graph in the book. First we must convert the temperatures into Celcius,

$$70 \text{ }^\circ\text{F} \text{ gives } 5(70 - 32)/9 = 21.1 \text{ }^\circ\text{C}$$

$$200 \text{ }^\circ\text{F} \text{ gives } 5(200 - 32)/9 = 93.3 \text{ }^\circ\text{C}$$

then, from the graph,

$$\text{at } 70 \text{ }^\circ\text{F} \text{ pressure } \approx 64 \text{ psi}$$

$$\text{at } 200 \text{ }^\circ\text{F} \text{ pressure } \approx 420 \text{ psi}$$

4.22

The simplest linear approximation is to simply make a straight line from the end-points, i.e., 70 and 90 °C. Thus from the graph we see that, at 70 °C, pressure = 260 psi at 90 °C, pressure = 400 psi so, a linear equation is,

$$p = kT + p_0$$

using the above values to solve for k and p_0 ,

$$260 = 70k + p_0$$

$$400 = 90k + p_0$$

subtracting,

$$(400 - 260) = (90 - 70)k$$

$$k = 140/20 = 7$$

and then, from the first equation,

$$p_0 = 260 - 70(7) = -230$$

so the equation is,

$$p = 7T - 230$$

It looks like the worst agreement will come at the midpoint temperature of 80 °C. From the graph we find the pressure at this temperature to be about 330 psi and the equation above gives 330 psi also. The linear approximation is quite good.

4.23

First we find the resistance of the RTD at the two temperature extremes,

$$R(20\text{ }^\circ\text{C}) = 100\ \Omega$$

$$R(100\text{ }^\circ\text{C}) = 100[1 + .0034(100 - 20)] = 127.2\ \Omega$$

To keep the self-heating below 0.05°C we need to keep the power below:

$$P = P_D \Delta T = (28\text{ mW}/^\circ\text{C})(0.05^\circ\text{C}) = 1.3\text{ mW}$$

Since $P = I^2 R$ we find the maximum current from the minimum resistance as,

$$I = \sqrt{\frac{P}{R}} = \sqrt{\frac{1.3}{100}} = 3.6\text{ mA}$$

Let's use 3 mA. If the RTD is used for R_4 in our standard bridge circuit then the current, and thus the power, will be determined by the value of R_2 and the excitation voltage. We will use 5 V for excitation so R_2 is found from the current limitation,

$$R_2 = \frac{5\text{ V} - (100\ \Omega)(3\text{ mA})}{3\text{ mA}} \approx 1567\ \Omega$$

Since the actual value is only for current limiting let's use 1600 Ω. We will use the same value for R_1 so that the bridge will be nulled at 20°C. The voltage at 100°C will be,

$$\Delta V = 10 \left[\frac{100}{100 + 1600} - \frac{127.2}{127.2 + 1600} \right] = 74.1\text{ mV}$$

This input to the amplifier must produce a +10-volt output, so the amplifier gain is,

$$K = 10/0.0741 = 135$$

We must be careful to connect the bridge to the amplifier so the output voltage is positive. The following circuit will provide this result.

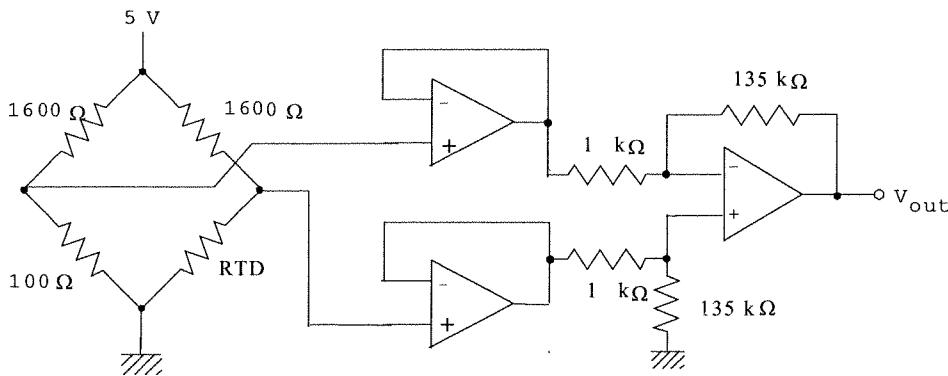

4.24

The Type K TC will produce the following voltage range,

$$\text{at } 200\text{ }^\circ\text{C } V_{TC} = 8.13\text{ mV}$$

$$\text{at } 350\text{ }^\circ\text{C } V_{TC} = 14.29\text{ mV}$$

The ADC reference is given to be 2.5 volts. The change from FEH to FFH occurs for an input voltage of

$$V_{ADC} = V_{ref} - V_{ref}/256 = 2.5 - 2.5/256\text{ V} = 2.49\text{ V}$$

Thus, we have the overall need for signal conditioning which translates 8.13 mV into 0 V and 14.29 mV into 2.49 V. The equation for this is,

$$V_{ADC} = mV_{TC} + V_0$$

so,

$$0 = 0.00813m + V_0$$

$$2.49 = 0.01429m + V_0$$

subtracting,

$$m = 2.49 / (0.01429 - 0.00813) = 404.2 \text{ and the offset is found as,}$$

$$V_0 = -0.00813(404.2) = -3.286 \text{ V}$$

The following circuit provides this transformation. Note that the high gain has been split between two op-amp circuits.

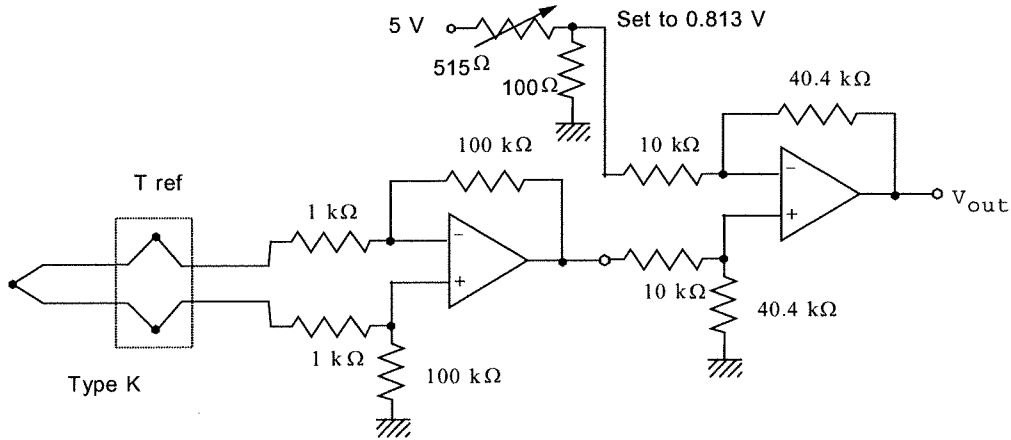

4.25

We need to determine the Type K TC voltages for the temperatures of interest in the problem and then design the appropriate signal conditioning. So, from the tables, assuming the reference is 0 °C,

$$V_{TC} \text{ at } 50 \text{ }^\circ\text{C} \text{ is } 2.02 \text{ mV}$$

$$V_{TC} \text{ at } 80 \text{ }^\circ\text{C} \text{ is } 3.36 \text{ mV}$$

$$V_{TC} \text{ at } 100 \text{ }^\circ\text{C} \text{ is } 4.10 \text{ mV}$$

Clearly we need signal conditioning with offset since the output is to be 0 to 2.0 volts for 50 to 80 °C. So, forming the equation for this signal conditioning,

$$V_{out} = mV_{TC} + V_0$$

thus,

$$0 = 0.00202m + V_0$$

$$2.0 = 0.00336m + V_0$$

subtracting,

$$m = 2 / (.00336 - .00202) = 1492.5$$

and

$$V_0 = -.00202(1492.5) = -3.015 \text{ V}$$

We can find the alarm voltage by substituting 4.10 mV into the output equation,

$$V_{alarm} = 1492.5(.0041) - 3.105 = 3.104 \text{ V}$$

Now, to provide this response we will use an instrumentation amplifier with a gain of 100 followed by a differential amplifier with a gain of 14.925. The offset voltage will be 3.015/14.925 = 0.202 V. A comparator with a trip voltage of 3.104 is used for the 100 °C alarm. The complete circuit follows.

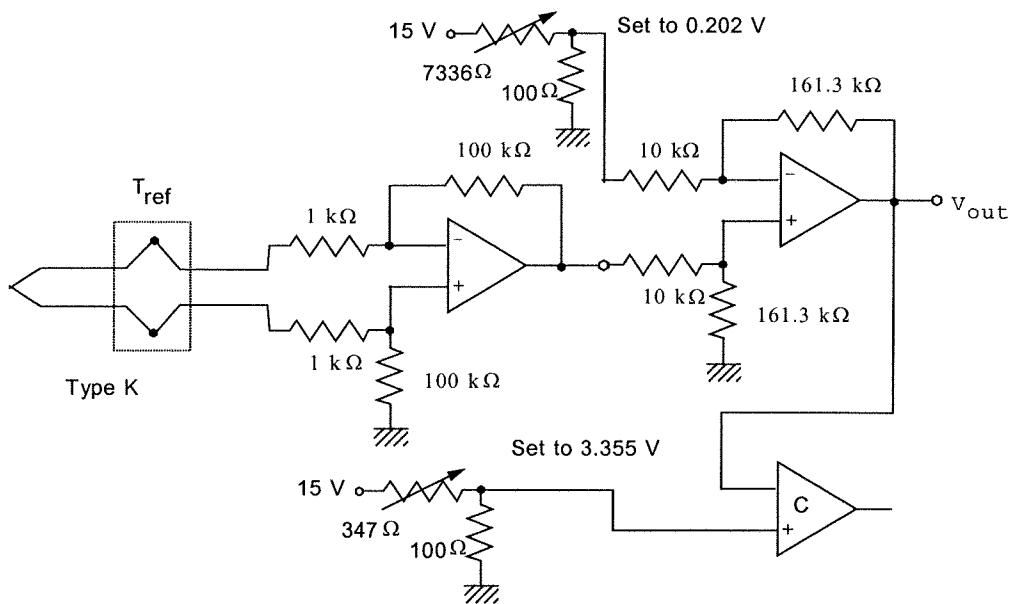

4.26

The RTD has specs of $R = 500 \Omega$ and $\alpha = 0.003 / ^\circ\text{C}$ both at 260°C . The dissipation constant is given as $P_D = 25 \text{ mW}/^\circ\text{C}$. This transducer is to be used to measure 500 to 600°F . Signal conditioning will provide a 0 to 5 volt output for this temperature range and the system accuracy must be $\pm 1^\circ\text{F}$.

Let us place the RTD in a bridge circuit. The power dissipated must be such that the temperature rise is less than 1°F , in fact let us use a factor of ten and make the design so the temperature rise is 0.1°F .

First we need to know the RTD resistances at the temperatures of interest,

$$T_{low} = 5(500 - 32)/9 = 260^\circ\text{C}$$

$$T_{high} = 5(600 - 32)/9 = 315.6^\circ\text{C}$$

then,

$$R_{low} = 500 \Omega$$

$$R_{high} = 500[1 + 0.003(315.6 - 260)] = 583.4 \Omega$$

Ok, now to find the bridge resistor in series with the RTD. Let us assume a 5 volt bridge excitation. The power dissipated in the RTD is found from the temperature rise allowed, 0.1°F . This can be expressed in Celcius as, $5(0.1)/9 = 0.056^\circ\text{C}$. So the power which can be dissipated in the RTD is,

$$P = \Delta T P_D = (0.056^\circ\text{C})(25 \text{ mW}/^\circ\text{C})$$

$$P = 1.4 \text{ mW}$$

Thus the maximum RTD current will be, $I = (P/R)^{1/2}$

$$I = (1.4 \times 10^{-3}/583.4)^{1/2} \approx 1.5 \text{ mA at } 583.4 \Omega$$

The bridge resistor in series with the RTD is thus found from this current,

$$I = .0015 = 5/(583.4 + R)$$

or,

$$R = 2749 \Omega \approx 2.75 \text{ k}\Omega$$

We verify that this gives,

$$\text{at } 500.0 \Omega, I = 5/3250 = 1.54 \text{ mA}, P = 1.18 \text{ mW}, \Delta T \approx 0.05 \text{ oC}$$

$$\text{at } 583.4 \Omega, I = 5/3333.1 = 1.5 \text{ mA}, P = 1.3 \text{ mW}, \Delta T \approx 0.05^\circ\text{C}$$

We will make the bridge null at 500°F (500Ω) so if we pick R_3 to be, say $1 \text{ k}\Omega$ then,

$$R_1 = R_2 R_3 / R_4 = (2750)(1000)/500 = 5500 \Omega.$$

Now the bridge voltage will be 0 V at 500°F and, at 600°F ,

$$\Delta V = 5[1000/6500 - 583.4/(2750+583.4)] = -0.1059 \text{ V} \quad \text{This must become } 5 \text{ volts for input to the}$$

ADC so an amplifier is needed with no offset and a gain of,

$$G = V_{out}/V_{in} = 5/(-0.1059) = -47.2$$

An op amp differential amplifier can easily provide this gain. The entire circuit is as follows:

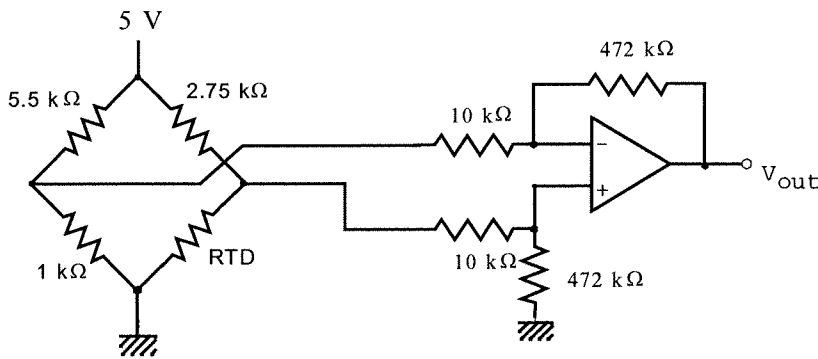

4.27

This is so typical of industry, a mixed unit problem. To summarize:

ADC: 5.00 V ref, 8-bits

Thermistor: 5.00 k Ω at 90°F with $P_D = 5 \text{ mW}/^\circ\text{C}$ and a slope of $-8 \Omega/^\circ\text{C}$

Requirements: 90°F to give 5AH out and 110°F to give 6EH out

We first set up the self-heating limitation. Each bit represents 1°F so let's try a restriction that self-heating should be a tenth of that or 0.1°F which is 0.056°C. Ok, $\Delta T = P/P_D$ so,

$$P < P_D \Delta T = (0.056)(0.005) = 0.28 \text{ mW}$$

Then, using $P = I^2 R$ at 90°F we can find the maximum current as,

$$I_{max} = [P/R]^{1/2} = [0.00028/5000]^{1/2} = 240 \mu\text{A}$$

For signal conditioning we will use the thermistor in the feedback of an op amp circuit. The equation for the

signal conditioning can be found from the two requirements given and the equation for the ADC,

$$\text{at } 90^\circ\text{F}, V_L = V_{ref} N/2^8 = (5.00)(90)/256 = 1.758 \text{ V}$$

$$\text{at } 110^\circ\text{F}, V_h = (5.00)(110)/256 = 2.148 \text{ V}$$

The thermistor resistance is 5.00 k Ω at 90°F. At 100°F we find the resistance from $5000 - (8 \Omega/^\circ\text{C})\Delta T(^\circ\text{C})$ or,

$$R_{110} = 5000 - (8 \Omega/^\circ\text{C})(110^\circ\text{F} - 90^\circ\text{F})(5/9) = 4911 \Omega$$

The current is to be kept below 240 μA so we use an inverter with -1 volt fixed input and 10 k Ω input resistance. Since the feedback current and input current are the same we are assured the thermistor current will be about 100 μA . The outputs from this circuit at the two limits will be,

$$\text{at } 90^\circ\text{F}: V_a = -(R_T/R) V_{in} = -(5000/10000)(-1) = 0.500 \text{ V}$$

$$\text{at } 110^\circ\text{F}: V_a = -(4911/10000)(-1) = 0.4911 \text{ V}$$

The op amp circuit is developed from,

$$1.758 = m(0.5000) + V_0$$

$$2.148 = m(0.4911) + V_0$$

solving, $m = -43.82$ and $V_0 = 23.67 \text{ V}$

$$V_{ADC} = 43.82(0.5401 - V_a)$$

The circuit below shows how this is provided by a differential amplifier.

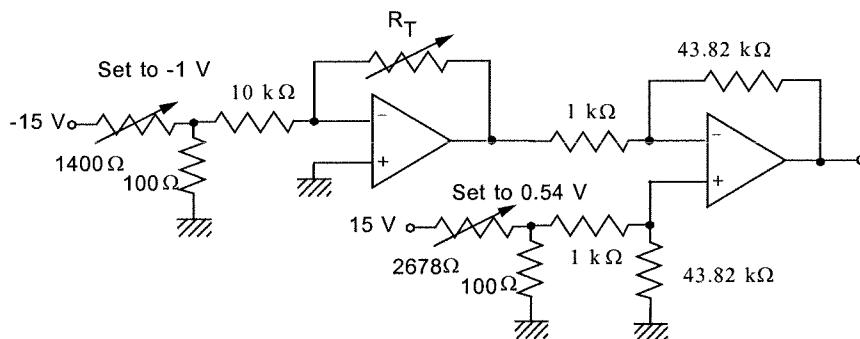

4.28

In Example 4.19 the following characteristics of the RTD and required signal conditioning were found:

(1) the RTD current must be kept < 13.7 mA to satisfy a self heating < 1 °C

(2) R at 50 °C = 141 Ω for which the output is to be 0 V.

R at 80 °C = 159 Ω for which the output is to be 2.0 V.

(3) An alarm is to be issued at 100 °C for which $R = 171 \Omega$.

In an inverting amplifier with an input voltage, V_{in} , and an input resistance R_1 , the output will be,

$$V_{out} = -(RTD/R_1)V_{in}$$

Clearly we will need to follow this with either a summing amplifier or differential amplifier to provide the needed offset to get 0 V at 50°C.

To start lets keep the current below 1 mA to give a safety factor against self-heating. Thus, since the current through both resistors must be the same,

$$V_{in}/R_1 = 0.001 \text{ A}$$

The value of V_{in} is somewhat arbitrary, suppose we use a value of $V_{in} = 1.0 \text{ V}$, then $R_1 = 1/.001 = 1000 \Omega$ and so,

$$V_{out} = -RTD/1000 \text{ volts}$$

This means voltages at the temperatures of interest of,

$$50 \text{ °C} : V_{out} = -141/1000 = -0.141 \text{ V}$$

$$80 \text{ °C} : V_{out} = -0.159 \text{ V}$$

$$100 \text{ °C} : V_{out} = -0.171 \text{ V}$$

The next stage of signal conditioning must satisfy, $V = mV_{out} + V_0$ with,

$$0 = -.141m + V_0$$

$$2.0 = -.159m + V_0$$

so, $m = 2/(-.159 + .141) = -111$ and $V_0 = 15.67 \text{ V}$

If a differential amplifier is used we would factor the value of m and write the required equation as,

$$V = -111(V_{out} - 0.141) = 111(0.141 - V_{out})$$

Thus the resistor ratio must be 111 and a divider is use to obtain the 0.141 V offset. The complete circuit is as follows:

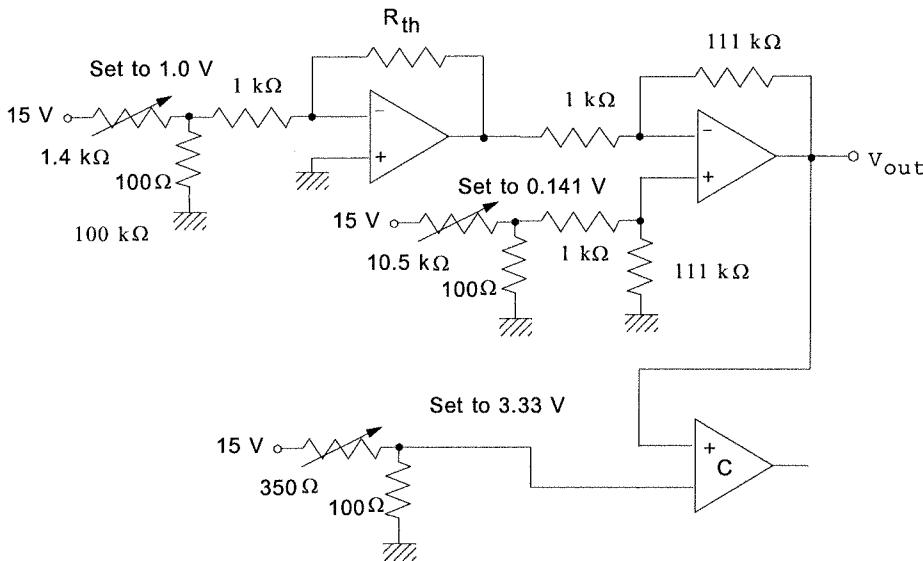

4.29

In summary, Type K TC, need 0 to 2.500 volts for 500 to 700°C temperature range. 12 mV/°C reference compensation is available. For the type K with a 0°C reference the outputs would be,

$$V(500^\circ\text{C}) = 20.65 \text{ mV}$$

$$V(700^\circ\text{C}) = 29.14 \text{ mV}$$

The overall transformation required, assuming a 0°C reference is given by,

$$V_{out} = mV_{TC} + V_0$$

$$0.0 = m(0.02065) + V_0$$

$$2.500 = m(0.02914) + V_0$$

Solving, we find $m = 294.5$ and $V_0 = -6.081 \text{ V}$

For the reference correction, the tables show the Type K varies at about 0.05 mV/°C. Thus the output of the compensation circuit is too large at 12 mV/°C by a factor of 240. If we amplify the TC output by 240 and then combine with the compensation signal, everything will work out ok. To get

the total gain of 294.5 we will need extra gain of 1.227. Combining everything the circuit equation is,

$$V_{out} = 1.227[240V_{TC} + V_{comp} - 4.956]$$

The circuit below satisfies this requirement.

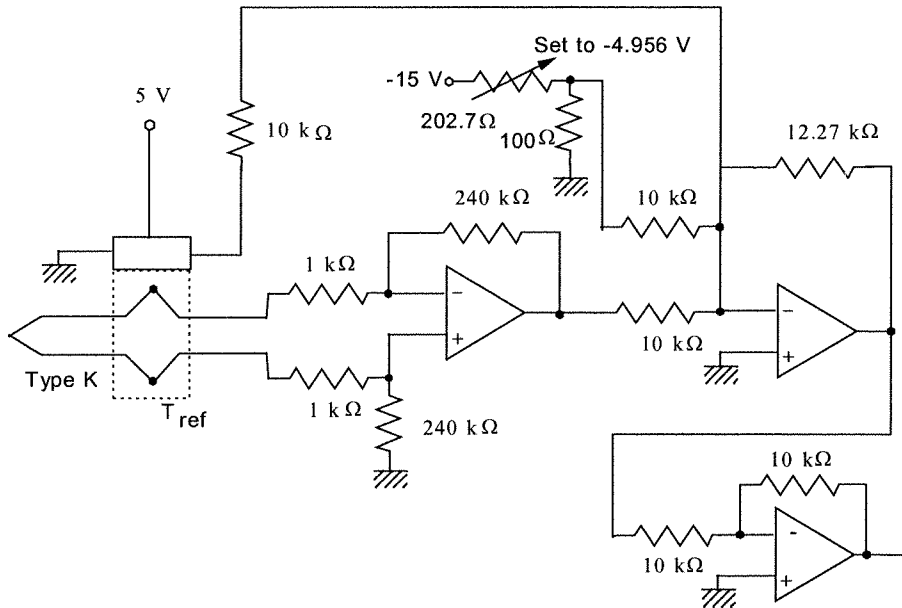

4.30

Well, to summarize, 50 to 100°C is a span of 50°C and a resolution of 0.1°C means 50/0.1 = 500 increments. An 8-bit computer provides only 256 but a 9-bit provides 512, so we must use a 9-bits at least. Since a 9-bit ADC is not common, we will use a 10-bit ADC, unipolar and with a 5.000 V reference. The expected resistance variation will be,

$$R_{50} = 306.5[1 + 0.0041(50 - 20)] = 344.2 \Omega$$

$$R_{100} = 306.5[1 + 0.0041(100 - 20)] = 407.0 \Omega$$

Let's use a bridge for the RTD (although an op amp circuit could be used). We must keep the self-heating below 0.01°C to maintain the 0.1°C resolution. Thus, $P/P_D = 0.01^\circ\text{C}$

$$P_{max} = (0.030)(0.01) = 0.3 \text{ mW},$$

Remembering that the power is given by $P = V^2/R$ we can determine the maximum voltage across the RTD as,

$$V_{max} = \sqrt{PR} = \sqrt{(0.3 \text{ mW})(344.2 \Omega)} = 0.32 \text{ V}$$

So let's make the voltage across the RTD 0.3 V at 50°C and null the bridge at this temperature. This means the other side of the bridge must be 0.3 V as well. We will use the RTD for R_3 in a standard bridge. Then the value of R_1 is found from

$$R_1 = \frac{(5 - 0.3)}{(0.3/344.2)} = 5393$$

If we make R_4 from the bridge 1 kΩ then the value of R_2 is found as,

$$R_2 = \frac{(5 - 0.3)}{(0.3/1000)} = 15.7 \text{ k}\Omega$$

This is shown in the schematic below for the bridge. Now, at 100°C we will have a bridge offset voltage of,

$$\Delta V = 5(407)/(407 + 5393) - 0.3 = 0.0509 \text{ V}$$

Since the input to the ADC needs to be, $5.000 - 5.000/2^{10} = 4.995$, we need an amplifier with a gain of $\text{Gain} = 4.995/0.0509 = 98.13$. The whole equation is,

$$V_{ADC} = 98.13[5R/(R + 5393) - 0.3]$$

and the circuit is given below.

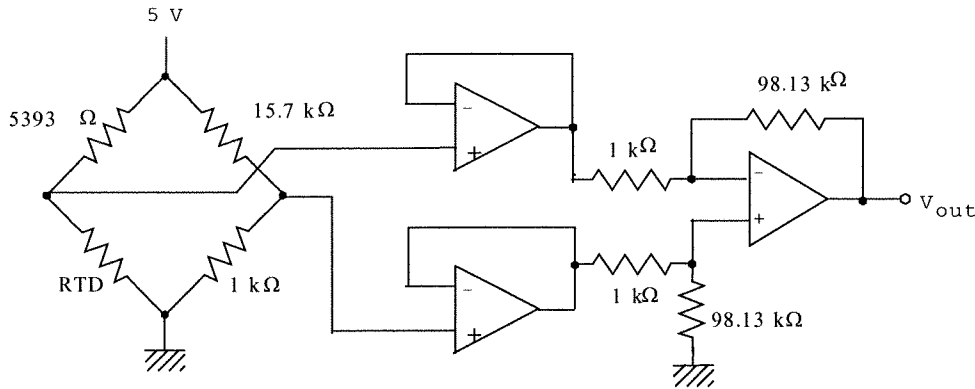

Supplementary Problems

S4.1

(a) We must connect enough thermocouples in series so that their combined voltage less that dropped across their internal resistance will still provide 5.0 volts across the load. The effective load resistance must be, $R_{load} = 5.0 \text{ V}/0.05 \text{ A} = 100 \Omega$. Suppose we use n -thermocouples. Then the total resistance will be $R_{total} = 0.05n$ and the total voltage will be $V_{total} = nV_{TC}$, where V_{TC} is the voltage of one thermocouple with the junction at 300°C and the reference at 25°C . We can now form an equation which will determine n ,

$$5.0 = nV_{TC} - (0.05n \Omega)(0.05 \text{ A})$$

From the 0°C reference tables for a Type J TC we find $V(300) = 16.33 \text{ mV}$ and $V(25) = 1.28 \text{ mV}$. Therefore the expected thermocouple voltage is $V_{TC} = 16.33 - 1.28 = 15.05 \text{ mV}$. We solve the preceding equation for n , $5.0 = 0.01505n - 0.0025n = 0.01255n$ so that $n = 398$. Therefore we will use 400 thermocouples to provide an even number. There are 8 wings to the device so there must be 50 thermocouples distributed uniformly along each wing. Note that power consumed by the radio will be about 252 mW.

(b) Maximum power is delivered into a load with the same internal resistance as the source. The internal resistance is simply, $R_L = R_{in} = 400(0.05 \Omega) = 20 \Omega$. The power delivered into 20Ω is found as $P = I^2 R_L = 20I^2$, where $I = 400V_{TC}/40 \Omega$ (net resistance seen by the source is the internal resistance plus the load resistance).

$$\text{At } 300^\circ\text{C } I = (400)(0.01505)/40 = 0.1501 \text{ A so } P = 20(0.1505 \text{ A})^2 = 0.453 \text{ W}$$

$$\text{At } 400^\circ\text{C we find } V_{TC} = 21.85 - 1.28 \text{ mV} = 20.57 \text{ mV}$$

$$I = (400)(0.02057)/40 = 0.2057 \text{ A so } P = 20(0.2057)^2 = 0.846 \text{ W}$$

(c) If the ambient drops to 10°C the voltage will be increased to $V_{TC} = 16.33 - 0.50 \text{ mV} = 15.83 \text{ mV}$. Therefore the total voltage will be $V_{total} = 400(0.01583) = 6.332 \text{ volts}$ while the radio load voltage will be,

$$V_L = 6.332 - 20(6.332/120) = 5.28 \text{ volts.}$$

The current into the radio will be 0.0528 A and the power consumed 278 mW. So, the radio will probably play louder.

S4.2

The RTD resistance is given by, $R_T = 300[1 + 0.0035(T - 25)]$

(a) for the signal conditioning we need to know the sensor resistance at 100°C and 220°C ,

$$R_{100} = 300[1 + 0.0035(100 - 25)] = 378.75 \Omega$$

$$R_{220} = 300[1 + 0.0035(220 - 25)] = 504.75 \Omega$$

To maintain the linearity let us put the RTD in the feedback of a simple inverting amplifier. Then if V_{in} is the input voltage and R_{in} the input resistor the output voltage will be,

$$V_T = -\frac{R_T V_{in}}{R_{in}} \quad \text{Let's keep the self heating at } 0.5^\circ\text{C} \text{ or less. Then the power to be}$$

dissipated in the sensor is found from $P \leq \Delta T P_D = (0.5^\circ\text{C})(25 \text{ mW}/^\circ\text{C}) = 12.5 \text{ mW}$. This requirement can be expressed in terms of the current using $P = I^2 R$ which gives $I = (P/R)^{1/2}$. We must use the largest value of resistance to get the smallest current so $R = 504.75 \Omega$ and we find,

$$I = \sqrt{\frac{0.0125}{504.75}} \approx 5 \text{ mA}$$

The same current flows through the input resistor so we have $(V_{in}/R_{in}) = 5 \text{ mA}$. For convenience we take $V_{in} = 5.1 \text{ volts}$ from a zener regulator, then $R_{in} = 1020 \Omega$. We can now specify the voltage for the endpoint temperatures,

$$V_{100} = -(378.75)(5.1)/1020 = -1.894 \text{ volts}$$

$$V_{220} = -(504.75)(5.1)/1020 = -2.524 \text{ volts}$$

This voltage range must be converted into -2.0 to +2.0 volts. As usual we form an equation,

$$V_{out} = mV_T + V_0$$

imposing our two conditions:

$$+2.0 = -2.524m + V_0$$

$$-2.0 = -1.894m + V_0$$

subtracting the second from the first gives, $4 = -0.63m$ so that $m = -6.349$. Then we find,

$V_0 = 2 + 2.524m = 2 - 16.02 = -14.02$. Therefore the equation is,

$$V_{out} = -6.349V_T - 14.02 = -6.349(V_T + 2.208)$$

We will use a differential amplifier to complete the design. The final circuit is shown in the following schematic,

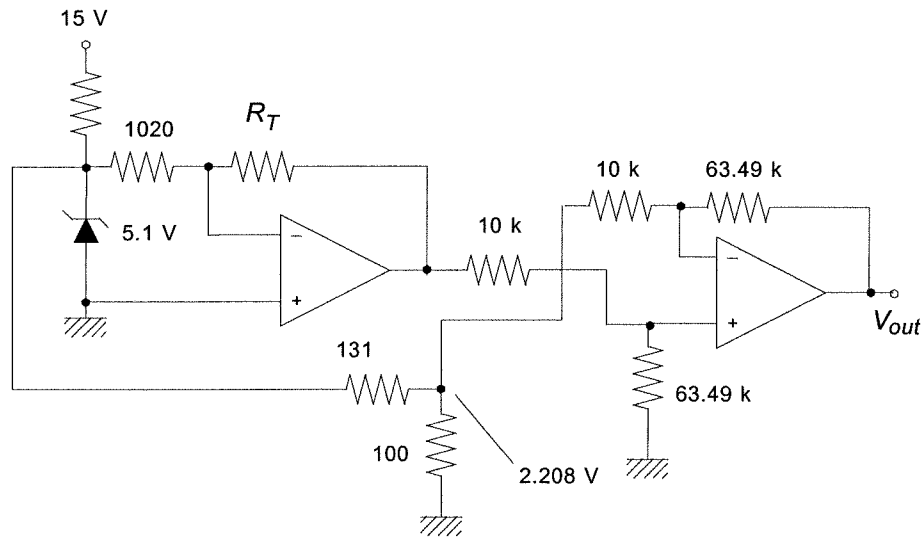

S4.3

First let's heat them up from ambient 21°C to 45°C operational temperature. This is a self-heating temperature rise of $\Delta T = 45 - 21 = 24^\circ\text{C}$. Since the dissipation constant is given we can determine the power which must be dissipated (This is all only approximate - the idea is to operate the thermistors at an elevated temperature, the exact value is not important):

$$P = \Delta TP_D = (24^\circ\text{C})(5 \text{ mW}/^\circ\text{C}) = 120 \text{ mW.}$$

The operating current is then found from

$$P = I^2 R \text{ or } I = (P/R)^{1/2} = (0.12/2000)^{1/2} \approx 8 \text{ mA}$$

From Ohm's law we find the amount of voltage which must be across the thermistor in order to get this current,

$$V = IR = (0.008)(2000) = 16 \text{ V}$$

We are to operate the bridge from a 20 V supply. Then, if the thermistors are in the bottom legs of the bridge, the upper bridge resistors must drop a voltage of $20 - 16 = 4 \text{ volts}$ at 8 mA,

$$R = 4/0.008 = 500 \Omega$$

Now we need an amplifier which will give an output of 6.0 volts when the wind is 60 mph. At 60 mph the exposed thermistor temperature is cooler by 7.7°C and the resistance *increases* by $24 \Omega/^\circ\text{C}$. Therefore the resistance will be $\Delta R = (7.7^\circ\text{C})(24 \Omega/^\circ\text{C}) = 184.8 \Omega$. The bridge off-null voltage is therefore,

$$\Delta V = 20 \left[\frac{2000}{2000 + 500} - \frac{2184.5}{2184.5 + 500} \right] = -0.275 \text{ V}$$

where, of course, the negative sign just denotes which way we chose to subtract the bridge voltages. This shows that the differential bridge amplifier will need a gain of,

$$G = 6.0/0.275 = 21.8$$

The following figure shows the complete circuit. Note that the bridge must be connected so the polarity comes out correctly.

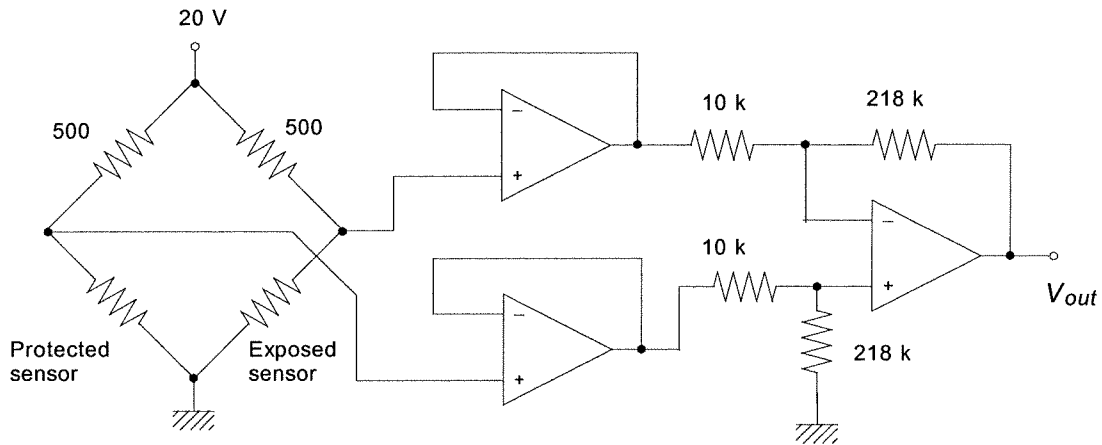

The table is completed by computing the new resistance, bridge off-null voltage and then output voltage. The completed table follows.

Speed (mph)	ΔT ($^{\circ}\text{C}$)	ΔR (Ω)	Bridge ΔV (V)	V_{out} (V)
0	0	0	0	0.0
10	-3.0	72	0.112	2.44
20	-4.5	108	0.166	3.62
30	-5.5	132	0.201	4.38
40	-6.3	151.2	0.228	4.97
50	-7.1	170.4	0.255	5.56
60	-7.7	184.8	0.275	6.00

(b) The following graph shows how the output voltage varies with wind speed. All in all this is not a very good sensor because of non-linearities.

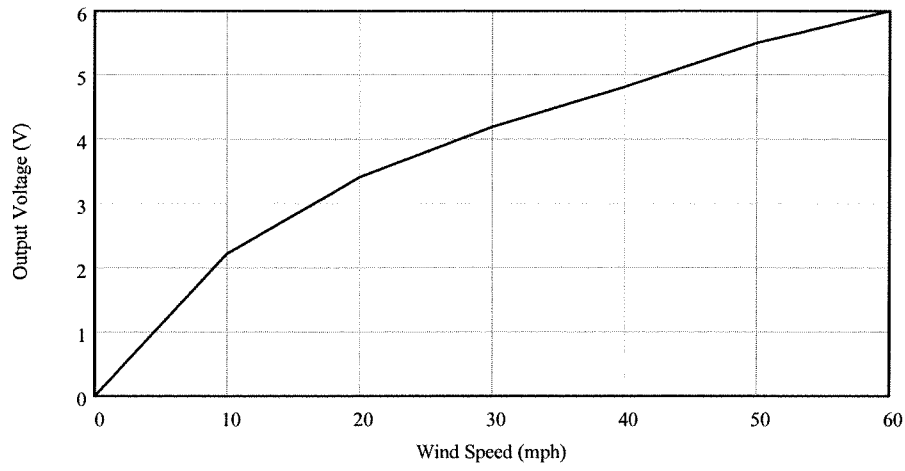

(c) The errors are greatest between 10 and 30 mph where they run from 146% to 46%!

CHAPTER 5

5.1

Well, if there are 0.25 mm between wires which cover 5 cm and the work piece motion is 12 cm then the resolution is found from a simple proportion:

$$0.25 \text{ mm}/50 \text{ mm} = \Delta x/120 \text{ mm}$$

$$\Delta x = 0.6 \text{ mm}$$

So the work piece motion resolution is 0.6 mm. To relate this to resistance change we note that there are 50/0.25 = 200 turns so each must have a resistance of 50 kΩ/200 = 250 Ω per turn. Thus since the resolution represents one turn, the resistance change is 250 Ω.

5.2

The signal conditioning will follow a simple linear formula relating output voltage to sensor resistance.

$$V_{out} = mR_s + V_0$$

where, $R = 0 \Omega$ gives $V_{out} = -6 \text{ V}$, and $R = 50 \text{ k}\Omega$ gives $V_{out} = 6 \text{ V}$. Thus,

$$-6 = m(0) + V_0$$

$$6 = m(50 \text{ k}\Omega) + V_0$$

wherefore, $V_0 = -6 \text{ volts}$, and $m = 2.4 \times 10^{-4} \text{ volts/ohm}$, so, $V_{out} = 0.00024R - 6$

Well, an inverting amplifier with R_s in the feedback provides an output voltage directly proportional to resistance and then a differential amplifier can be used to subtract the 6 volts and change the sign. Look at the circuit below. We pick $V_1 = -1 \text{ volt}$ so that the output of the first amplifier is, $V_{out1} = R_s/R_2$. Then the gain of the differential amplifier is R_7/R_6 and the other input is a fixed 1 volt. The total equation is,

$$V_{out} = \frac{R_7}{R_6 R_2} R_s - \frac{R_7}{R_6}$$

You can see that if $R_7/R_6 = 6$ and $R_2 = 25 \text{ k}\Omega$ then the conditions are satisfied.

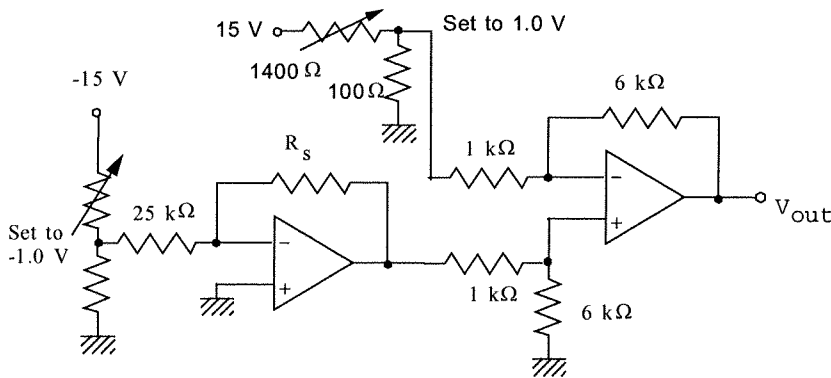

5.3

We know that for a capacitor, $C = \epsilon A/d$. In this instrument it is d which changes to change the capacity while ϵ and A remain constant. For the nominal d of 1 mm, we have,

$$C = 880 \text{ pF} = \epsilon A/1 \text{ mm}$$

for $d = 1.02 \text{ mm}$ the capacity will thus be,

$$C_+ = \epsilon A/1.02 \text{ mm} = (\epsilon A/1 \text{ mm})(1 \text{ mm}/1.02 \text{ mm})$$

$$C_+ = 880 \text{ pF}/1.02 = 863 \text{ pF}$$

and for $d = 0.98 \text{ mm}$,

$$C_- = 880 \text{ pF}/0.98 = 898 \text{ pF}$$

so the total change is $\Delta C = 35 \text{ pF}$.

5.4

The following bridge circuit employs 880 pF capacitors for all three arms and the transducer in the other, for Z_4 . Excitation is by a 10 V (rms), 10 kHz generator. We find the off null voltage for C_4 ranging from 863 pF to 898 pF.

$$\Delta E = 10 \left[\frac{Z_3}{Z_1 + Z_3} - \frac{Z_4}{Z_2 + Z_4} \right]$$

of course, $Z = 1/(j\omega C)$, but since there is a $j\omega$ in every term the above equation for off null voltage reduces to,

$$\Delta E = 10 \left[\frac{C_1}{C_1 + C_3} - \frac{C_2}{C_2 + C_4} \right]$$

for the two cases we thus have,

$$\Delta E_1 = 10(880/1760 - 863/1743) = -48.7 \text{ mV (rms)}$$

$$\text{and } \Delta E_2 = 10(880/1760 - 898/1778) = -50.6 \text{ mV (rms)}$$

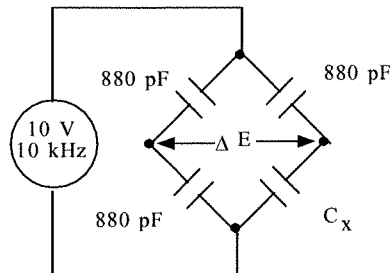

5.5

We have $R_A = 100 \text{ k}\Omega$, $R_B = 20 \text{ k}\Omega$ and, from Example 5.2, C_h varies linearly from 34.75 to 69.50 pF as the height, h , varies from 1 cm to 2 cm so we can write $C_h = 34.75h \text{ pF}$. The total period of the signal is $T_{\text{tot}} = T_{\text{low}} + T_{\text{high}} = 0.693(2R_B + R_A)C$, and the frequency is given by, $f = 1/T_{\text{tot}}$. Since C_h is in parallel with a 1000 pF capacitor, $C = 34.75h + 1000 \text{ pF}$

We can thus write the frequency as,

$$f = 1.0307 \cdot 10^{-5} / C = 1.307 \cdot 10^7 / (34.75h + 1000)$$

so, $f_1 = 9.96 \text{ kHz}$ and $f_2 = 9.64 \text{ kHz}$ and the net change of 320 Hz. A plot of the frequency versus displacement is constructed using the equation for frequency in terms of h given above.

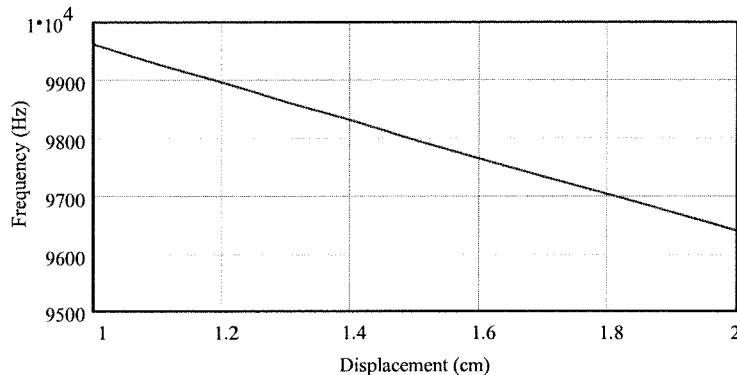

You can see that the frequency varies nearly linearly with displacement.

5.6

The equation for voltage versus displacement, D , can be written, $V_D = (2.5 \text{ mV/mm})D$.

(a) The range of output voltage is,

$$V_D(-20 \text{ cm}) = -0.5 \text{ volts to } V_D(+20 \text{ cm}) = +0.5 \text{ volts}$$

(b) The required resolution of 0.5 mm can be used to find the number of states required from -20 cm to +20 cm, which is 40 cm or 400 mm.

$$\Delta D = 400 \text{ mm} / 0.5 \text{ mm} = 800 \text{ states}$$

A 9-bit ADC has 512 states (not enough) but a 10-bit ADC has 1024 states, so we must use at least a 10-bit converter.

(c) The bipolar converter input range is from -2.5 volts to +2.5 volts (actually $2.5 - 5/1024 = 2.495$ volts, but let's use 2.5). Thus we have,

$$V_{\text{ADC}} = mV_D$$

We know there is no intercept in the equation since V_{ADC} should be zero when V_D (and D) = 0. If we decided to use the more exact figure of 2.495 at +20 cm an intercept would be needed. So the slope is $m = V_{ADC}/V_D = 2.5/0.5 = 5$. Therefore we need an amplifier with a gain of 5. We can use a noninverting amplifier, as follows.

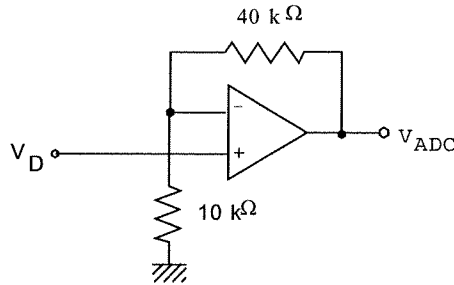

5.7

A simple linkage is lever arms of different length. In this case a simple proportional ratio establishes the proper relations,

$$x/y = 1 \text{ m}/0.3 \text{ m}, \text{ so } y = 0.03x. \text{ If we make } y = 6 \text{ cm} \text{ then } x = 2 \text{ m}.$$

The following figure shows how this would look.

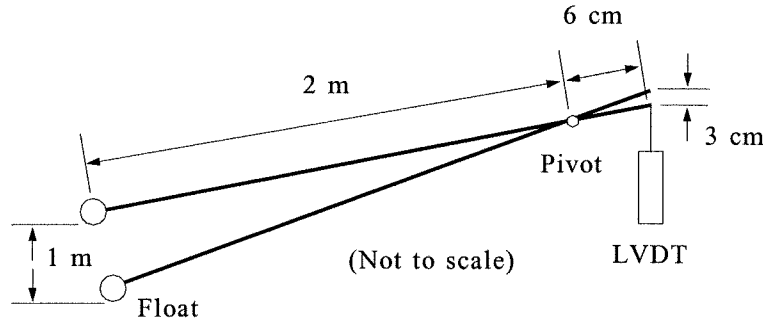

The resolution is determined by 1 meter and 2^{10} states.
 $\text{resolution} = 1.0 \text{ m}/1024 = 0.97 \text{ mm}$

5.8

If the alcohol is at a level of x from the bottom then the rest, $L - x$, contains air. The total capacity is then given by,

$$C_{TOT} = C_{AL} + C_{air}$$

$$C_{TOT} = \epsilon_0 \frac{2\pi R(L-x)}{d} + K\epsilon_0 \frac{2\pi Rx}{d}$$

To get the resolution, we differentiate,

$$\frac{dC_{TOT}}{dx} = \epsilon_0 (K-1) \frac{2\pi R}{d}$$

When $\Delta x = 2 \text{ cm}$ we can find the change in capacity,

$$\Delta C_{TOT} = (8.85 \text{ pF/m})(26-1)(2\pi)(0.0575 \text{ m})(0.02 \text{ m})/0.005 \text{ m} = 319.7 \text{ pF} \approx 320 \text{ pF}$$

A resolution of 2 cm out of 5 m means $5/0.02 = 250$ states. Therefore an 8-bit ADC, which has 256 states will be satisfactory.

5.9

The following bridge circuit is to be used:

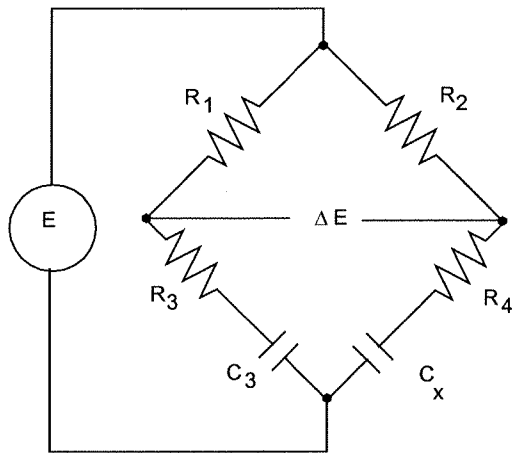

Let's design for a null at 0 m level, where $C_x = 0.0032 \mu\text{F}$. At null we have the condition, $Z_1 Z_4 = Z_2 Z_3$. Using the specific circuit this becomes,

$$R_1(R_4 - j/\omega C_x) = R_2(R_3 - j/\omega C_3)$$

The null must be for real and imaginary parts,

$$R_1 R_4 = R_2 R_3 \text{ and } R_1/C_x = R_2/C_3$$

Well, there are two equations, five variables and $C_x = 0.0032 \mu\text{F}$, so we can pick three of the variables. Let's try $C_3 = 0.02 \mu\text{F}$ and $R_1 = R_3 = 1 \text{ k}\Omega$. From the second we get $R_2/R_1 = C_3/C_x = 6.25$. Then we since $R_1 = 1 \text{ k}\Omega$, $R_2 = 6.25 \text{ k}\Omega$ and from the resistance relation we see that $R_4 = 6.25 \text{ k}\Omega$ also.

The offset voltage is given by,

$$\Delta E = E \left[\frac{R_3 - j/\omega C_3}{R_1 + R_3 - j/\omega C_3} - \frac{R_4 - j/\omega C_x}{R_2 + R_4 - j/\omega C_x} \right]$$

Let's use an excitation of 5 V rms at 1 kHz. Now we need to express C_x in terms of x , the level of the liquid in the tank. The following figure defines all the aspects of the capacitor system,

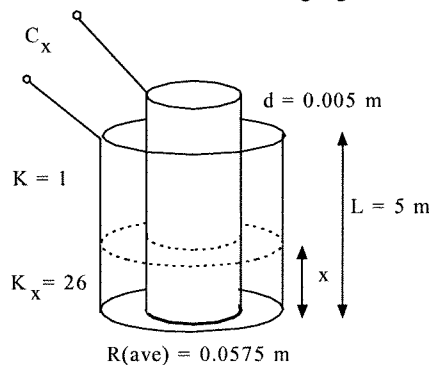

The total capacity is given by the sum of that part in air and alcohol,

$$C_x = C_{al} + C_{air} = [\epsilon_0 \pi R/d] (K_x x + KL - Kx) = 319.7 [25x + 5] \text{ pF}$$

Substituting all the values and simplifying provides the following equation for the voltage,

$$\Delta E = 5 \left[\frac{1 - 7.96j}{2 - 7.96j} - \frac{6.25 - j \frac{249}{25x + 5}}{12.5 - j \frac{249}{25x + 5}} \right]$$

The magnitude and phase of this complex number can now be plotted versus x . These plots were done easily by entering the above complex equation directly into MathCad and plotting the magnitude and phase.

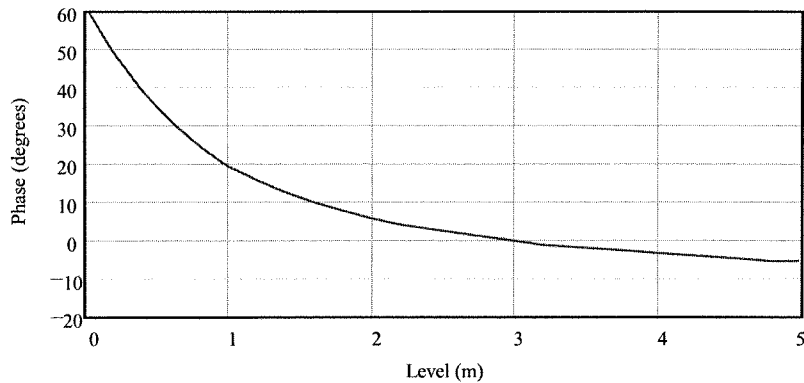
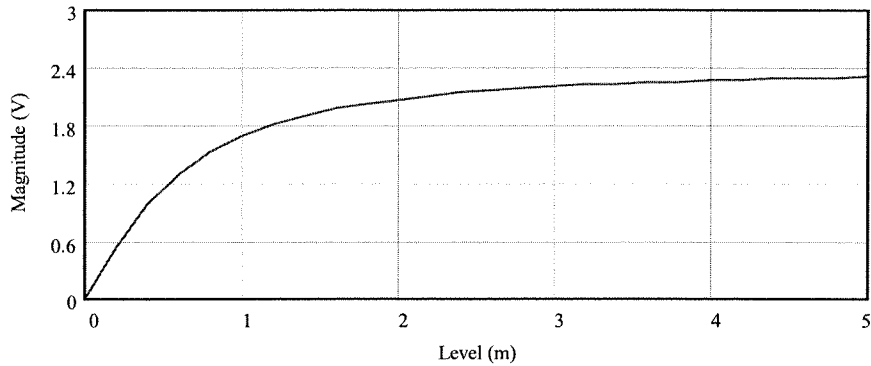

5.10

For an aluminum beam of 6.2 cm diameter the area is given by,

$$A = \pi D^2/4 = \pi(0.062 \text{ m})^2/4 = 0.003 \text{ m}^2$$

The weight of a 550 kg mass is,

$$F = mg = (550 \text{ kg})(9.8 \text{ m/s}^2) = 5390 \text{ N}$$

(a) The stress is given by,

$$\text{Stress} = F/A = 5390/0.003 = 1.8 \times 10^6 \text{ N/m}^2$$

(b) The strain is found from,

$$E = \text{Stress}/\text{Strain}$$

so,

$$\text{Strain} = \text{Stress}/E$$

for aluminum $E = 6.89 \times 10^{10} \text{ N/m}^2$

$$\text{Strain} = 1.8 \times 10^6 / 6.89 \times 10^{10}$$

$$\text{Strain} = 2.6 \times 10^{-5}$$

or

$$\text{Strain} = 26 \mu$$

5.11

We solve Eq. (5.10) for ΔA , (we drop the subscript)

$$lA = (l + \Delta l)(A - \Delta A) = l(1 + \Delta l/l)(A - \Delta A)$$

Cancel l and solve for $A - \Delta A = A/(1 + \Delta l/l)$. This is now used in Eq. (5.11),

$$R = \rho l(1 + \Delta l/l)/(A - \Delta A) = (\rho l/A)(1 + \Delta l/l)^2 = R_0[1 + 2(\Delta l/l) + (\Delta l/l)^2]$$

So if $\Delta l/l$ is much less than one, the squared term will be very small.

5.12

Well, 1μ of strain will give a resistance change of, $\Delta R = GF(R)(\Delta l/l) = (2.06)(120 \Omega)(10^{-6})$
 or $\Delta R = 2.472 \times 10^{-4} \Omega$. So the first question is what temperature will cause this same resistance change. This can be found from the Chapter 4 relation for RTDs, $\Delta R = \alpha_0 R \Delta T$, so

$$\Delta T = (2.472 \times 10^{-4} \Omega) / [(0.0034 \text{ } ^\circ\text{C})(120 \Omega)] = 6 \times 10^{-4} \text{ } ^\circ\text{C}!!$$

Now, the temperature rise due to electrical power dissipation is given by,

$$\Delta T = P/P_D \text{ where } P = I^2 R \text{ so we can solve for the current,}$$

$$I = [P_D \Delta T / R]^{1/2} = [25 \text{ mW}/^\circ\text{C} / (6 \times 10^{-4} \text{ } ^\circ\text{C}) / 120 \Omega]^{1/2} = 0.354 \text{ mA} = 350 \mu\text{A}$$

5.13

The gage factor is given by $GF = (\Delta R/R) / (\Delta l/l)$ so,

$$\Delta R = GF(\Delta l/l)R$$

$$\Delta R = 2.14(144 \times 10^{-6})(120 \Omega)$$

$$\Delta R = 0.037 \Omega$$

5.14

Since this is a design problem there are many correct solutions. We start by noting that since a smooth variation is required in 1000 spans, we must use a variable resistor in one leg of the bridge for nulling. Let us pick this resistor to be a 100 Ω unit, since that is a common value.

The first question is how much strain gage resistance change occurs for the 1000 strain spans. From the gauge factor we find,

$$\Delta R = GF(\Delta l/l)R = 2.03(0.001)(120) = 0.2436 \Omega$$

Of course we assume the temperature compensation gage, R_3 , is always 120 Ω . Let us take R_1 to be fixed and R_2 to be the unit which will be varied, by switching and by the variable.

Then the basic design is,

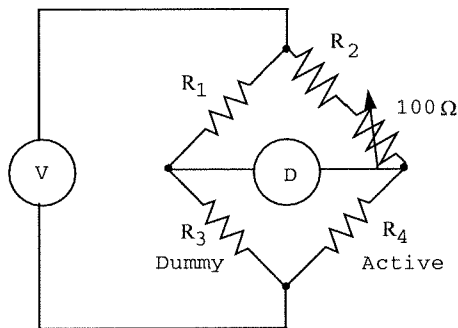

Assume the bridge is nulled when the strain is 0 μ and the variable resistor has a value of 0 Ω . Also the bridge is nulled when the strain is 1000 μ and the resistor is 100 Ω . This gives two equations from the basic bridge null equation, $R_1 R_4 = R_2 R_3$,

$$120R_1 = 120R_2$$

and

$$120.2436R_1 = 120(R_2 + 100)$$

From the first we get $R_1 = R_2$. The second then gives, $0.2436R_1 = 12000$

so,

$$R_1 = R_2 = 49261.1 \Omega$$

Now, for each increase of 1000 μ , there will be an extra 100 Ω resistor in the R_2 leg. For example if the strain is 2500 μ then,

$$\Delta R = (120)(2.03)(2500 \times 10^{-6}) = 0.609 \Omega,$$

then,

$$(120.609)(49261.1) = 120(49261.1 + R)$$

$$R = 250 \Omega \text{ which is } 50 \Omega \text{ from the variable plus } 200 \Omega \text{ from fixed resistors.}$$

The final design is thus as follows:

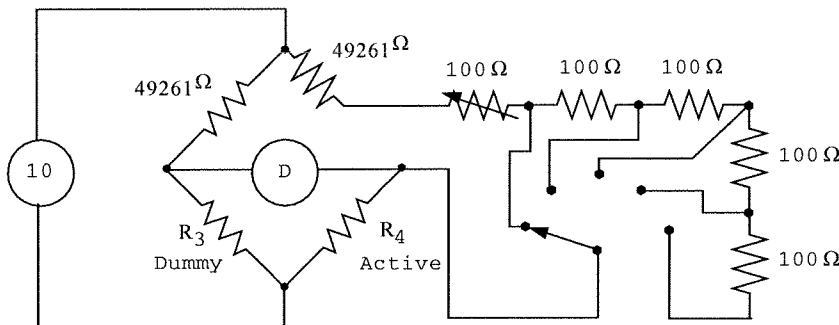

To obtain the desired resolution of 5 $\mu\text{m}/\text{m}$ we must specify the resolution of the null detector. Thus we find the offset voltage for a strain of 5 μ ,

$$\Delta R = \frac{(120)(2.03)(5 \times 10^{-6})}{120} = \frac{0.001218 \Omega}{120.001218}$$

$$\Delta V = 10 \left[\frac{R_D}{49261.1 + 120} - \frac{R_A}{49261.1 + 120.001218} \right]$$

$$\Delta V = -0.2 \mu\text{V}$$

Thus the resolution must be 200 nV.

5.15

The exact bridge offnull voltage is given by

$$\Delta V = V_s \left[\frac{R_D}{R_D + R_1} - \frac{R_A}{R_A + R_2} \right] \quad \text{where} \quad R_A = R \left(1 + \frac{\Delta R}{R} \right) \quad \text{and} \quad \frac{\Delta R}{R} = GF \frac{\Delta \ell}{\ell}$$

We make the assumption that $R_1 = R_2 = R_D = R$. Then the offnull voltage becomes,

$$\Delta V = V_s \left[\frac{R}{R + R} - \frac{R \left(1 + \frac{\Delta R}{R} \right)}{R \left(1 + \frac{\Delta R}{R} \right) + R} \right] = \frac{V_s}{2} \left[1 - \frac{1 + \frac{\Delta R}{R}}{1 + \frac{1}{2} \frac{\Delta R}{R}} \right] = \frac{V_s}{2} \left[\frac{1 + \frac{1}{2} \frac{\Delta R}{R} - 1 - \frac{\Delta R}{R}}{1 + \frac{1}{2} \frac{\Delta R}{R}} \right]$$

We use the expansion that $\frac{1}{1+x} = 1 - x + \frac{x^2}{2!} - \frac{x^3}{3!} + \dots$ for $x < 1$ to write the offnull voltage as,

$$\Delta V = \frac{V_s}{2} \left(-\frac{1}{2} \frac{\Delta R}{R} \right) \left[1 - \frac{1}{2} \frac{\Delta R}{R} + \frac{1}{8} \left(\frac{\Delta R}{R} \right)^2 + \dots \right]$$

Then, if we multiply this out and keep only terms in first order on the quantity $\Delta R/R$ we get the result of Equation (5.14)

$$\Delta V = -\frac{V_s}{4} \frac{\Delta R}{R} = -\frac{V_s}{4} GF \frac{\Delta \ell}{\ell}$$

To find the error we compare the exact value of ΔV with that calculated from this last expression. The approximation expression gives,

$$\Delta V = - (10/4)(2.05)(500 \times 10^{-6}) = -2.5625 \text{ mV}$$

To find the exact we first compute the change in strain gauge resistance,

$$\Delta R = (2.05)(120 \Omega)(500 \times 10^{-6}) = 0.123 \Omega$$

Thus $R_A = 120.123 \Omega$. Now we substitute into the exact ΔV ,

$$\Delta V = 10[0.5 - 120.123/240.123] = -2.5612 \text{ mV}$$

So the error is 1.3 μV or 0.05%!!

5.16

Ok, the problem here is that the GF depends upon strain. We can relate the weight and strain by the simple expression, $\Delta l/l = (1000/300)W = 10W/3$ and we can relate the strain and resistance change by the expression,

$$\Delta R = R(GF)(\Delta l/l) = 300(GF)(\Delta l/l)$$

So the process is to find the strain, look the GF up on the graph and then compute the change in resistance.

Weight	Strain (μ)	-GF (from graph)	ΔR (Ω)
0	0	160	0
50	167	108	5.4
100	333	75	7.5
150	500	52	7.8
200	667	35	7.0
250	833	20	5.0
300	1000	12	3.6

A graph of this data demonstrates the nonlinear variation of resistance and weight (strain)

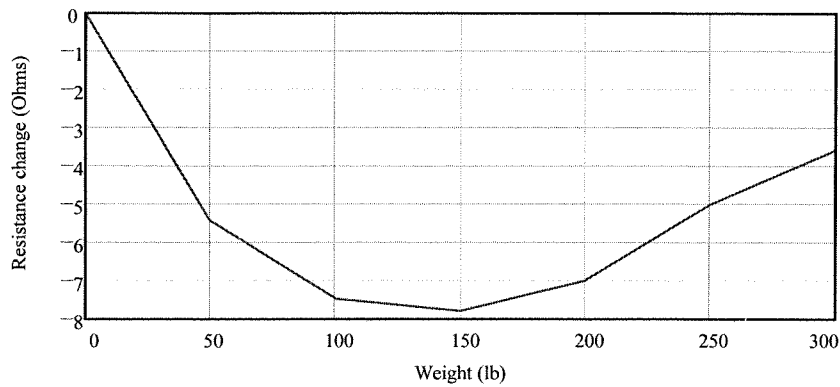

5.17

For the signal conditioning, the active and temperature compensation strain gages will be placed in a bridge circuit. A differential amplifier and following amplifier will be used to provide a signal such that 0 lbs results in 0 volts to the ADC and an output of 00H while 5000 lbs results in 4.995 volts to the ADC and an output of FFH. Example 5.10 showed that the bridge output was 0 to 175.0 V for a 0 to 5000 lb force. Thus the total gain required is,

$$G = 4.995/175 \times 10^{-6} = 28543$$

Let us make the differential gain $G_1 = 500$, then the following amplifier gain must be,

$$G_2 = 28543/500 = 57.1$$

The circuit below provides the required signal conditioning. The pounds per bit is simply,

$$\Delta W = 5000/2^{10} = 4.88 \text{ lb}$$

A plot of hex output versus weight in pounds follows, where the ADC output is expressed as a base-10 integer. It is very nearly linear because only a very small band of bridge voltage is involved.

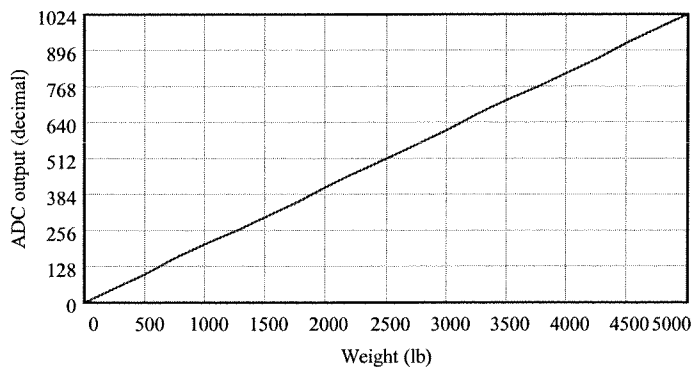
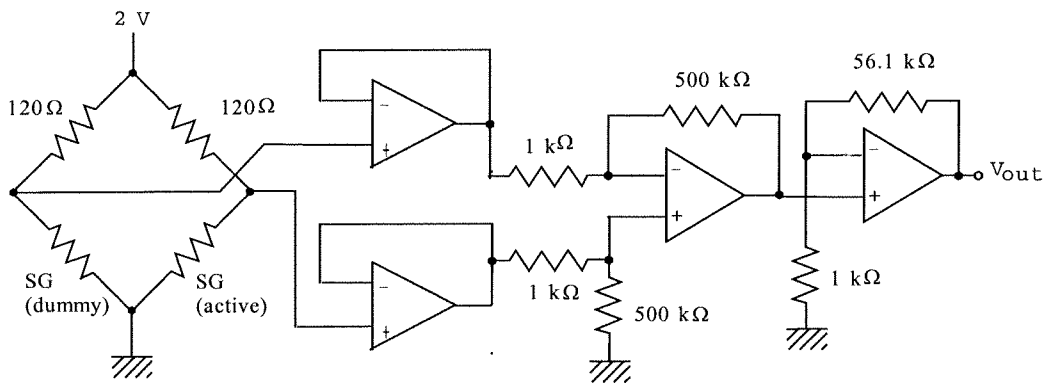

5.18

Clearly the structure of the system must be as follows,

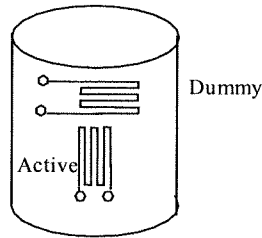

Since the active gauge will be under compression, its resistance will decrease. The change in resistance per pound is found from the basic relation between compressional stress and strain,

$$E = \text{stress/strain} = (F/A)/(\Delta l/l)$$

where

$$E = 11.73 \times 10^{11} \text{ N/m for copper,}$$

$$A = \pi D^2/4 = \pi(6 \text{ in} \times .0254 \text{ m/in})^2/4$$

$$= 1.824 \times 10^{-2} \text{ m}^2$$

Since 1 lb = 4.448 N we find the strain for one pound as,

$$(\Delta l/l) = \frac{4.448 \text{ N}}{(1.842 \times 10^{-2} \text{ m}^2)(11.73 \times 10^{11} \text{ N/m}^2)}$$

$$(\Delta l/l) = 2.06 \times 10^{-10} \quad \text{then the resistance change}$$

is,

$$\Delta R = (120)(2.02)(2.06 \times 10^{-9})$$

$$\Delta R = 5 \times 10^{-8} \Omega !!$$

5.19

Temperature compensation is provided automatically since all gauges will change in resistance with temperature the same fashion. So if they all go up 0.1Ω because of heating the bridge voltage would not change. They need to be wired into the bridge so that one side of the bridge divider voltage goes up because of both gauges and the other side voltage goes down because of both gauges. Note from Figure 5.46 that if the beam is bent down gauges A and B will be under tension and their resistances will increase. Gauges C and D will be under compression so their resistances will decrease. So we wire these into the bridge as follows:

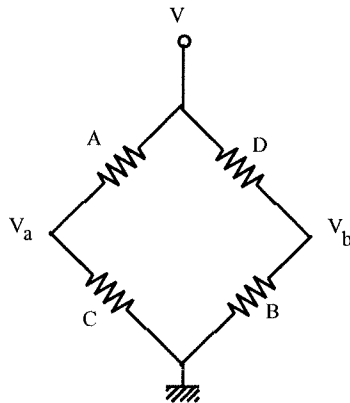

You can see that V_a will decrease from the effects of both gauges A and C. V_b will increase from the effects of both gauges, B and D.

To find the off-null voltage we just use the bridge equation where we note that for gauges A and B,

$$R = R_0 + R_0 GF \frac{\Delta l}{l}$$

while for gauges C and D,

$$R = R_0 - R_0 GF \frac{\Delta l}{l}$$

Now we construct the bridge off-null voltage

$$\Delta V = V_s \left[\frac{R_0 + R_0 GF \frac{\Delta l}{l}}{R_0 + R_0 GF \frac{\Delta l}{l} + R_0 - R_0 GF \frac{\Delta l}{l}} - \frac{R_0 - R_0 GF \frac{\Delta l}{l}}{R_0 - R_0 GF \frac{\Delta l}{l} + R_0 + R_0 GF \frac{\Delta l}{l}} \right]$$

After some algebra this reduces to,

$$\Delta V = V_s GF \frac{\Delta l}{l}$$

which is four times more sensitive than a bridge with only one active gauge.

5.20

Well we can just add another active and dummy gauge to the column, but we must wire them into the bridge so that the effect of stress is not cancelled. Below is the column with the four gauges, labeled A, B, C and D. Note that B and D are dummy gauges and that both A and C decrease in resistance with strain (weight). The bridge circuit is shown to the right.

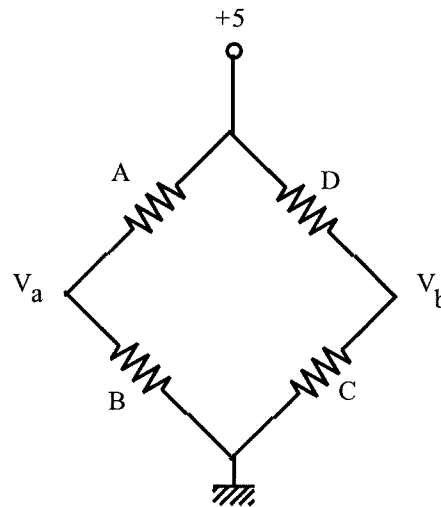
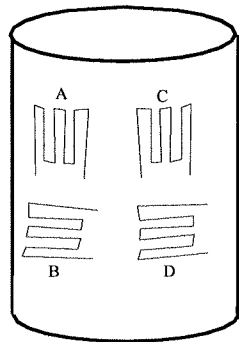

Look at the bridge circuit. You can see that V_a will be caused to increase but V_b will be caused to decrease so the effect is doubled. The off-null voltage is given by,

$$\Delta V = 5 \left[\frac{120}{120 + 120 + 120(2.02) \frac{\Delta l}{l}} - \frac{120 - 120(2.02) \frac{\Delta l}{l}}{120 + 120 - 120(2.02) \frac{\Delta l}{l}} \right]$$

which reduces to,

$$\Delta V = \frac{10.1 \frac{\Delta l}{l}}{2 - 2.02 \frac{\Delta l}{l}} \approx 5.05 \frac{\Delta l}{l} \quad \text{assuming } \Delta l/l \ll 1$$

In Problem 5.18 we found that for 1 lb , $\Delta l/l = 2.06 \times 10^{-10}$. Therefore for 1000 lb we have a voltage of,

$$\Delta V = (5.05)(2.06 \times 10^{-10}) = 1.04 \times 10^{-6} \text{ V}$$

5.21

Rotational rate in revolutions per minute (RPM) converted to radians per second, as,

$$R = (10^4 \text{ rev/min})(1 \text{ min}/60 \text{ s})(2\pi \text{ rad/rev})$$
$$R = 1047.2 \text{ rad/s}$$

5.22

An acceleration of 1 g is 9.8 m/s^2 .

$$(a) v = v_0 + at = v_0 + gt, \text{ but } v_0 = 0 \text{ and } g = 9.8 \text{ m/s}^2$$

$$v = (9.8 \text{ m/s}^2)(5 \text{ s}) = 49 \text{ m/s}$$

$$(b) x = x_0 + v_0t + at^2/2, \text{ but } x_0 = v_0 = 0$$

$$x = (9.8 \text{ m/s}^2)(5 \text{ s})^2/2$$

$$x = 122.5 \text{ m}$$

5.23

We first convert the force to newtons,

$$F = (2.7 \text{ lb})(4.448 \text{ N/lb}) = 12 \text{ N}$$

Then, by Newtons law,

$$a = F/m = 12 \text{ N}/5.5 \text{ kg}$$

$$a = 2.2 \text{ m/s}^2$$

5.24

The shock is the effective de-acceleration experienced by the transistor. It accelerates under gravity for a distance of 1.5 meters. Therefore it attains a velocity (starting from rest) given by the expression,

$$v^2 = 2ax = 2gx$$

thus,

$$v = [2(9.8 \text{ m/s}^2)(1.5 \text{ m})]^{1/2} v = 5.5 \text{ m/s}$$

The shock results when the transistor speed changes from this value to zero in 2.7 ms,

$$a_s = \Delta v/\Delta t = (5.5 \text{ m/s})/(2.7 \text{ ms})$$

$$a_s = 2037 \text{ m/s}^2$$

or,

$$a_s = 2037/9.8 = 207 \text{ g's}$$

5.25

$$a_{peak} = \omega^2 x_0,$$

where $x_0 = (5 \times 10^{-3})/2 = 2.5 \times 10^{-3} \text{ m}$ (peak) and

$$\omega = 2\pi f = 2\pi(16) = 100.5 \text{ rad/s}$$

so,

$$a_{peak} = (100.5)^2(2.5 \times 10^{-3}) = 25.25 \text{ m/s}^2 \text{ since } 1 \text{ g} = 9.8 \text{ m/s}^2,$$

we find,

$$a_{peak} = 25.25/9.8$$

$$a_{peak} = 2.58 \text{ g's}$$

5.26

The natural frequency is given by,

$$f_n = (1/2\pi)[k/m]^{1/2}$$

thus,

$$f_n = (1/2\pi)[140/.05]^{1/2}$$

$$f_n = 13.3 \text{ Hz}$$

5.27

A diagram helps to understand how the instrument works,

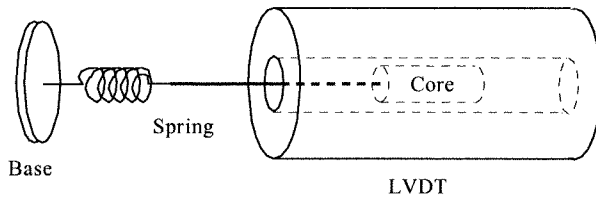

(a) For a relation between acceleration and output voltage we have two facts. First the voltage, V , is related to the displacement, Δx , by,

$$V = (0.31 \text{ mV/mm})\Delta x = (0.31 \text{ V/m})\Delta x$$

Second, for a spring mass accelerometer the relation between spring, mass, displacement and acceleration is given by

$$k\Delta x = ma$$

or,

$$\Delta x = (m/k)a$$

thus we find a relation between voltage and acceleration,

$$V = (0.31)(m/k)a = (0.31)(0.05/240)a$$

$$V = (6.46 \times 10^{-5})a$$

or,

$$a = (15500)V \quad (\text{to three significant figures}) \text{ where } V \text{ is in volts and } a \text{ in } \text{m/s}^2$$

(b) The maximum measurable acceleration is found from the condition that the maximum core displacement is $\pm 2 \text{ cm}$. Thus, the maximum voltage is,

$$V_{max} = (0.31)(\pm 0.02) = \pm 6.2 \text{ mV}$$

and so the maximum acceleration is,

$$a_{max} = (15500)(\pm 0.0062)$$

$$a_{max} = \pm 96.1 \text{ m/s}^2$$

(c) The natural frequency is, $f_n = (1/2\pi)[240/.05]^{1/2} \quad f_n = 11 \text{ Hz}$

5.28

Well, velocity is the integral of acceleration. We have a voltage proportional to acceleration, if we integrate this voltage we will have an output voltage proportional to velocity.

Let's write the relation from Problem 5.25, above, as,

$$V_a = Ka \quad \text{where } K = 6.46 \times 10^{-5} \text{ V/(m/s}^2)$$

then the output from a standard op amp integrator will be,

$$V_v = -\frac{1}{RC} \int V_a dt = -\frac{K}{RC} \int a dt = -\frac{K}{RC} v$$

Clearly we need an inverting amplifier to get rid of the negative sign. The values of R and C are found from the requirement that the scale factor be 2 mV/(m/s) ,

$$K/(RC) = 0.002 \quad \text{or } RC = K/0.002 = 6.46 \times 10^{-5}/0.002$$

$$RC = 0.00323$$

Let's pick $C = 1 \text{ }\mu\text{F}$ and $R = 1 \text{ M}\Omega$ so that $RC = 1$.

Then the inverting amplifier will be given a gain of -

$(1/0.00323) \approx 31$ to provide an integrator output of, $V_{v1} = -Kv$

and an inverting amplifier output of

$$V_v = Jv \quad \text{where } J = 0.002 \text{ V/(m/s)}$$

Since distance is the integral of velocity we use another integrator to find position. The values of R and C for this integrator are selected to provide the scale factor of 0.5 V/m .

$$V_x = -\frac{1}{RC} \int V_{v1} dt = -\frac{K}{RC} \int v dt = -\frac{K}{RC} x$$

so,

$$K/(RC) = 0.5 \quad \text{or } RC = K/0.5 = 6.46 \times 10^{-5}/0.5$$

$$RC = 1.29 \times 10^{-4} \text{ s}$$

if we pick $C = 0.1 \text{ }\mu\text{F}$ then $R = 1.29 \text{ k}\Omega$. The complete circuit is as follows.

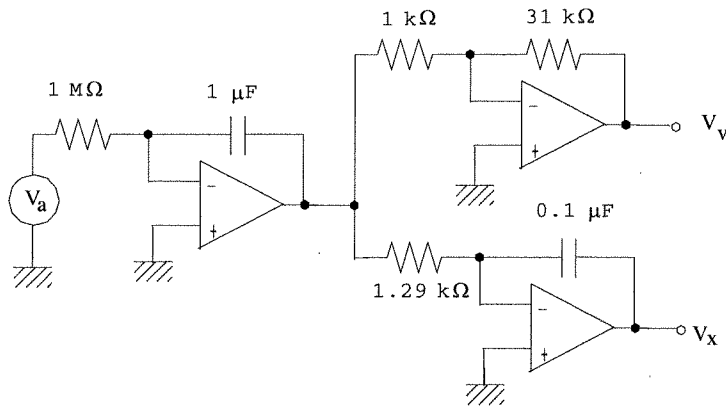

5.29

First we check that the test frequency of 110 Hz is much less than $0.1f_n = 450$ Hz. Therefore the accelerometer is acting as a true accelerometer and not a displacement transducer. The expression for acceleration in vibration is,

$$a = -\omega^2 x_0 \sin(\omega t)$$

where x_0 = the vibration peak displacement and $\omega = 2\pi f$. The peak acceleration is given by,

$$a_p = \omega^2 x_0$$

so,

$$x_0 = a_p / \omega^2$$

The peak acceleration is found from the measured voltage,

$$a_p = (3.6 \text{ V}) / (0.061 \text{ V/g}) = 59 \text{ g}$$

or,

$$a_p = (59)(9.8 \text{ m/s}^2) = 578.4 \text{ m/s}^2$$

thus,

$$x_0 = 578.4 \text{ m/s}^2 / (2\pi 4500)^2 = 1.21 \times 10^{-3} \text{ m}$$

$$x_0 = 1.21 \text{ mm}$$

5.30

The relation between gage resistance and shock can be found by simply working through the principles of the instrument. Clearly a shock will cause compression or extension of the force rod. This will result in a strain in the rod which will be picked up by the strain gage. So, for the gage we have,

$$\Delta R/R = GF(\Delta l/l)$$

For the rod under a force, F, we have,

$$E = (F/A) / (\Delta l/l)$$

or,

$$\Delta l/l = F/(EA)$$

Finally from Newton's law for the mass under acceleration, there will be a force,

$$F = ma$$

combining,

$$a_g \frac{\Delta R}{R} = \frac{GFma}{EA} = \frac{9.8GFm}{EA}$$

Using $E = 10^8 \text{ N/m}^2$, $GF = 2.03$, $R = 120 \Omega$ and $A = 2 \times 10^{-4} \text{ m}^2$ gives,

$$\Delta R = (2.39 \times 10^{-3} \Omega/\text{g}) a_g$$

$$a_g = \text{shock in g's}$$

5.31

A standard resistance bridge can be used to convert the strain gage resistance change of the accelerometer of Problem 5.28 into a voltage change. Let's use 120 Ω resistors in the other arms and a 5.0 volt excitation. Note the gage is under compression. The off-null voltage is,

$$\Delta V = 10[120/240 - R_g/(120 + R_g)] \quad \text{but,}$$

$$R_g = 120 - \Delta R = 120 - 0.00239a_g$$

so,

$$\Delta V = 5 \left[\frac{120}{120+120} - \frac{120-0.00239a_g}{120+120-0.00239a_g} \right]$$

After some algebra this can be written,

$$\Delta V = 2.5 - \frac{300 - 0.01195a_g}{240 - 0.00239a_g}$$

This voltage is plotted below as a_g varies from 0 to 5000 g's. It is very nearly linear because not much off-null voltage ever occurs.

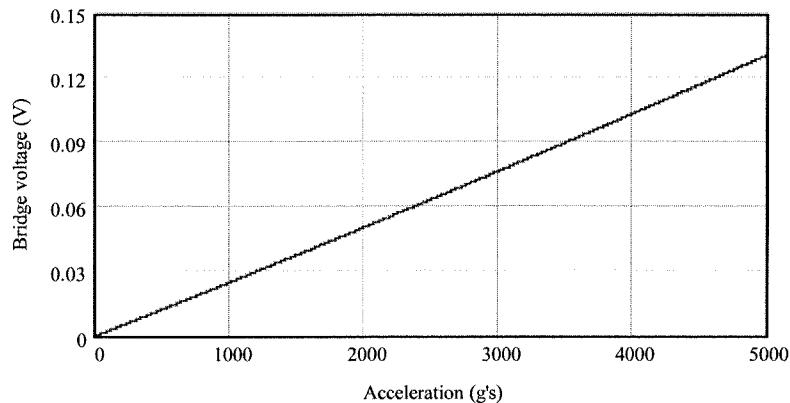

5.32

The relation between pressure and a column of liquid is,

$$p = Wgh = 9.8Wh \text{ for } p \text{ in N/m}^2 \text{ (Pascals)}$$

(a) The density of water is 10^3 kg/m^3 , so a column 3.3 m high provides,

$$p = 9.8(10^3)(3.3) = 32340 \text{ N/m}^2$$

since $1 \text{ atm} = 101330 \text{ N/m}^2$, we have

$$p = 32340/101330 = 0.32 \text{ atm}$$

(b) If the liquid were mercury the density, W , is a factor of 13.6 higher, thus,

$$p = (13.6)(0.32 \text{ atm}) = 4.35 \text{ atm}$$

(c) Since $1 \text{ Pa} = 1 \text{ N/m}^2$, in the first case we have,

$$p = 32 \text{ kPa}$$

and in the second,

$$p = (13.6)(32 \text{ kPa}) = 0.44 \text{ MPa}$$

5.33

To convert from psi to Pa we use $1.45 \times 10^{-4} \text{ psi/Pa}$. Thus,

$$p = (1500 \text{ psi})/(1.45 \times 10^{-4} \text{ psi/Pa})$$

$$p = 10.3 \times 10^6 \text{ Pa} = 10.3 \text{ MPa}$$

Since 1 atmosphere = 14.7 psi we have,

$$p = (1500 \text{ psi})/(14.7 \text{ psi/Atm}) = 102 \text{ Atm}$$

5.34

Force on a diaphragm is the effective area times the pressure difference,

$$F = (p_1 - p_2)A_{\text{eff}} = \Delta p A_{\text{eff}}$$

We must first convert the pressure to Pa to make the units consistent.

$$\Delta p = (5 \text{ psi})/(1.45 \times 10^{-4} \text{ psi/Pa})$$

$$\Delta p = 3.45 \times 10^4 \text{ Pa}$$

now,

$$F = (3.45 \times 10^4 \text{ Pa})(25 \times 10^{-4} \text{ m}^2)$$

$$F = 86.25 \text{ N}$$

We could also express the result in pounds,

$$F = 86.25 \text{ N}/(4.448 \text{ N/lb}) = 19.4 \text{ lb}$$

5.35

We find the maximum speed by the speed which creates a pressure of 5 kPa. To be consistent with units we find the density in kg/m³, 1 gm/cm³ = 1 10⁻³kg/10⁻⁶ m³ = 10³ kg/m³. Now for the speed,

$$v_{max} = (2p/\rho)^{1/2} = [2(5 \times 10^3 \text{ Pa})/(10^3 \text{ kg/m}^3)]^{1/2} = 3.16 \text{ m/s (about 7 mph)}$$

The output voltage is given by $V = (40 \text{ mV/kPa})p = (1/2)(40 \times 10^{-6})(10^3 \text{ kg/m}^3)v^2$. This simplifies to $V = 0.02v^2$. The following graph shows the expected non-linearity because the pressure is related to the square of the speed.

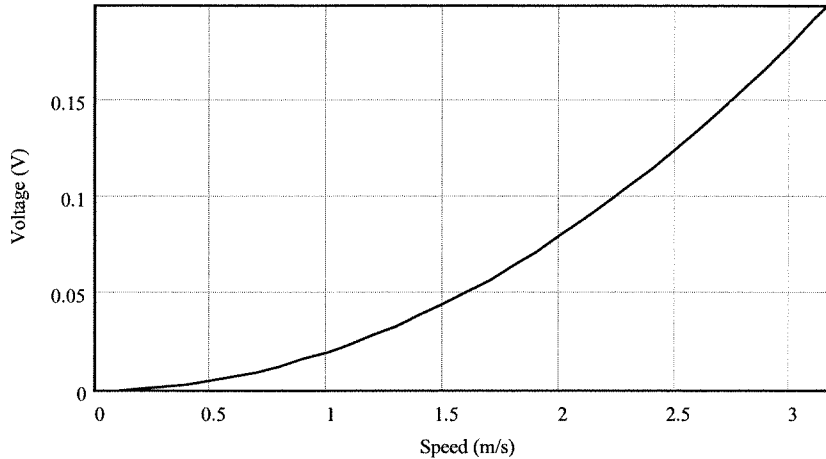

5.36

Bellows: spring constant; $k = 3500 \text{ N/m}$, mass $m = 50 \text{ gms}$ with area, $A = 0.5 \text{ in}^2$.

(a) A pressure of 20 psi will result in a deflection where the spring force and the pressure force are balanced. Oops, first we must convert to a common set of units. Ok, converting to SI:

$$A = (0.5 \text{ in}^2)(0.0254 \text{ m/in})^2 = 3.23 \times 10^{-4} \text{ m}^2$$

$$p = (20 \text{ lb/in}^2)/(0.2248 \text{ lb/N})(0.0254 \text{ m/in})^2 = 137.9 \text{ kPa}$$

Now,

$$k\Delta x = pA \quad \text{so} \quad \Delta x = pA/k = (137.9 \times 10^3 \text{ Pa})(3.23 \times 10^{-4} \text{ m}^2)/(3500 \text{ N/m})$$

$$\Delta x = 1.27 \text{ cm}$$

(b) The natural frequency is given by,

$$f_n = \frac{1}{2\pi} \sqrt{\frac{k}{m}} = \frac{1}{2\pi} \sqrt{\frac{3500 \text{ N/m}}{0.05 \text{ kg}}} = 42.1 \text{ Hz}$$

5.37

The total mass on the platform is given by Newton's Law as,

$$m = F/g = 258 \text{ N}/(9.8 \text{ m/s}^2)$$

$$m = 26.3 \text{ kg}$$

The flow rate in kg/hr is given by, $Q = mR/L$ where R is the rate of flow in m/hr and L the length of the platform. Solving for R ,

$$R = LQ/m = (1 \text{ m})(5200 \text{ kg/hr})/(26.3 \text{ kg})$$

$$R = 197.7 \text{ m/hr}$$

5.38

A water flow of 52.2 gal/hr is converted to kg/hr by using the known density of water and the conversion of gal into m³.

$$Q = (52.2 \text{ gal/hr})(3.785 \times 10^{-3} \text{ m}^3/\text{gal})$$

$$Q = 0.198 \text{ m}^3/\text{hr}$$

The density of water is 1000 kg/m³, so

$$Q_m = (0.198 \text{ m}^3/\text{hr})(10^3 \text{ kg/m}^3)$$

$$Q_m = 198 \text{ kg/hr}$$

To get the flow rate through a 2 inch diameter pipe we use, $Q = Av$ or $v = Q/A$, where $Q = \pi d^2/4$ but the diameter must be in m,

$$d = (2 \text{ in})(0.0254 \text{ m/in}) = 0.0508 \text{ m}$$

so,

$$v = 4(0.198 \text{ m}^3/\text{hr})/(\pi \times 0.0508^2) = 97.7 \text{ m/hr or,}$$

$$v = (97.7 \text{ m/hr})/(3600 \text{ s/hr}) = 0.027 \text{ m/s}$$

5.39

We know that $Q = K[\Delta p]^{1/2}$ so,

$$\Delta p = (Q/K)^2$$

Q will be in m^3/hr but the valve constant is in minutes, so we need a unit conversion 60 min/hr .

$$\Delta p = \left[\frac{Q}{(0.4 \frac{\text{m}^3/\text{min}}{(\text{kPa})^{1/2}})(60 \text{ min/hr})} \right]^2 = \left[\frac{Q}{24} \right]^2$$

This function is plotted below. Notice the nonlinear relation between pressure and flow.

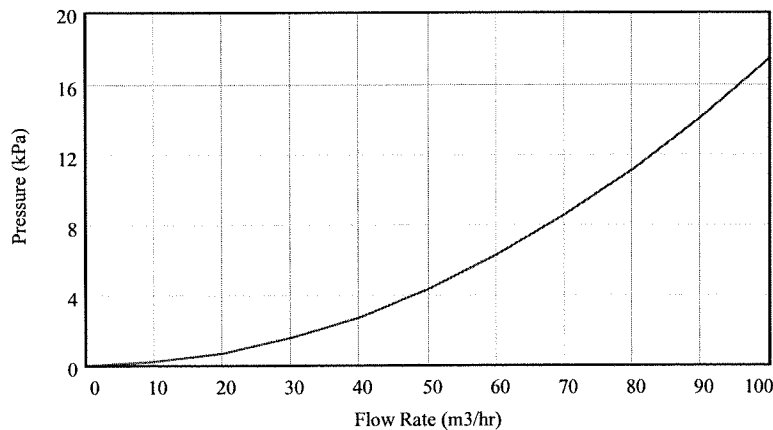

Supplementary Problems

S5.1

(a) If the level is 9 m then the distance from transmitter to surface is 2 m and the total distance traveled is 4 m so the time is,

$$T_0 = (4 \text{ m})/(300 \text{ m/s}) = 13.33 \text{ ms}$$

In a similar way if the level is 1 m then the distance from the sensor is 10 m and the total distance traveled is 20 m,

$$T_1 = (20 \text{ m})/(300 \text{ m/s}) = 66.67 \text{ ms}$$

(b) The system will count down from some preset value, N , where f_c is the counting frequency and T is the count time. Then we can form an equation for the count at any time T as,

$$N_L = N - f_c T$$

There are two unknowns in this equation, N and f_c . They can be found by requiring that the count be 10 when the count time is that for a level of 1.0 meters and 90 when the count time is that for a level of 9 meters,

$$90 = N - f_c(0.01333)$$

$$10 = N - f_c(0.06667)$$

Subtracting the second from the first gives, $80 = f_c(0.05334)$ so that $f_c = 1500 \text{ Hz}$. Substituting this into the second equation gives ,

$$10 = N - (1500)(0.06667) \text{ so that } N = 110.$$

So the equation relating count time and read-out is, $N_L = 110 - 1500T$

This means that the preset value of the counter is to be 110 (01101110_2) and the frequency of the counter clock should be 1500 Hz.

(c) The following diagram completes the design. It works something like this: The rising edge of the 1 s master clock sends out a 10 μs pulse which loads the 110 preset into the counter and clocks a high to the output of the D F/F to start the counter. It also starts a 500 μs pulse which starts the ultrasonic transmitter and disables the receiver. At the conclusion of the 500 μs the transmitter is turned off and the receiver enabled. When the echo is received the output of the receiver clears the count F/F to stop the counting. For whatever time remains on the 1 s master clock the display shows this count.

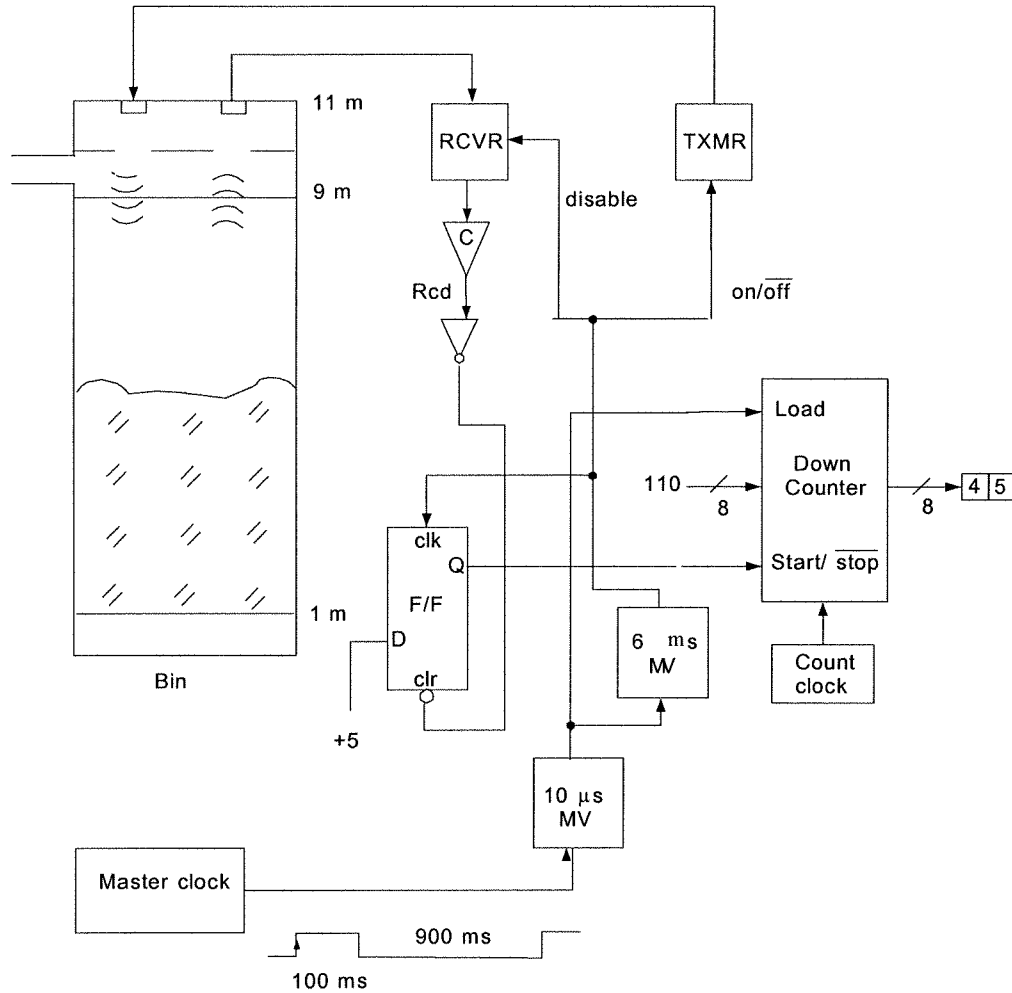

S5.2

The following figure shows how the four gauges are mounted in active orientation and connected in the bridge so that all contribute to the bridge off-null voltage. The voltage at *a* is driven low by both gauge resistance changes while that at *b* is driven high by both gauge resistance changes.

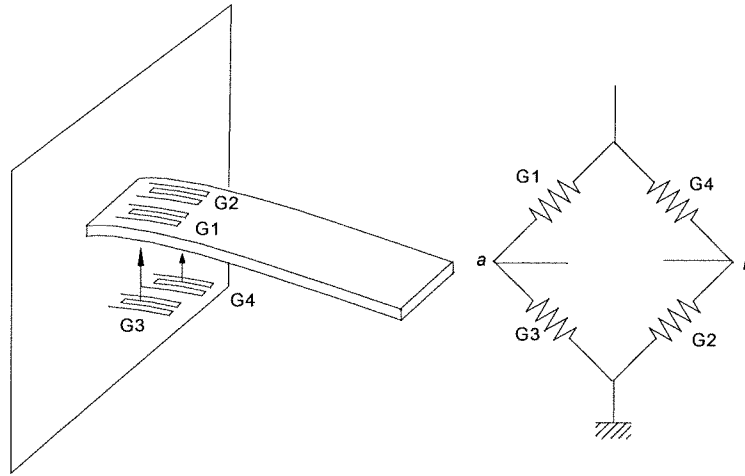

S5.3

(a) We first need a temperature compensated bridge. Let's just make the two fixed resistors 300 Ω as well, then the bridge is nulled with no strain. The two semiconductor strain gauges are placed in the lower legs of the bridge resistors as shown in the figure.

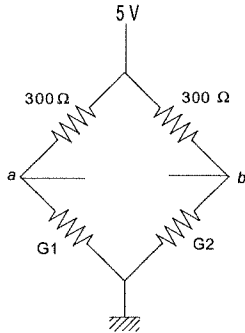

We make G1 the active gauge and G2 the temperature compensation gauge. As a semiconductor strain gauge the gauge factor is negative so the resistance change will be given by,

$$\Delta R = -300 \frac{\Delta l}{l} GF$$

But, since the gauge is under compression the strain will also be negative so the resistance will actually increase,

$$\Delta R = 300 \left| \frac{\Delta l}{l} GF \right|$$

Then the bridge off-null voltage will be given by the expression

$$\Delta V = 5 \left[\frac{R}{R + 300} - \frac{300}{300 + 300} \right] = 5 \left[\frac{300 + |\Delta R|}{600 + |\Delta R|} - 0.5 \right]$$

Where for the semiconductor gauge the GF depends upon strain by Figure 5.45. At the endpoint of 500 μ the GF is found from Figure 5.45 to be about -42 so

$$|\Delta R| = (300 \Omega)(500 \times 10^{-6})(42) = 6.3 \Omega$$

Therefore the bridge off-null voltage is given by, $\Delta V = 5[306.6/606.3 - 0.5] = -0.02598 \text{ V} \approx 0.026 \text{ V}$.

We need a 5.0 volt output so we need a differential amplifier with a gain of $G = 5.0/0.025 = 192.3$.

The following figure shows the completed design.

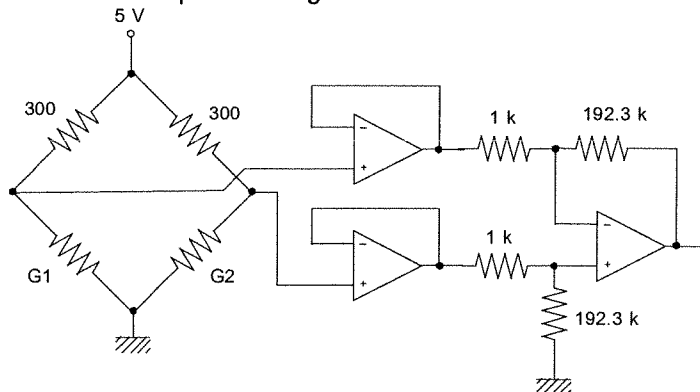

(b) For a plot versus mass flow rate we need to convert the flow rate into strain. So,

for the strain gauge we have, $\frac{\Delta l}{l} = \frac{F}{EA}$ where $E = 6.89 \times 10^{10} \text{ N/m}^2$ is the modulus of elasticity of aluminum, $A = \pi r^2 = \pi(10^{-2})^2 = \pi \times 10^{-4} \text{ m}^2$ is the cross sectional area and F is the force in Newtons. F is found from the mass of material on the platform, $F = mg$. The mass of material is found from the flow equation, $Q = mR/L$ where m is the mass, $R = 0.3 \text{ m/s}$ the speed and $L = 1.5 \text{ m}$ the length. So, putting this all together we find,

$$\frac{\Delta l}{l} = \frac{mg}{EA} = \frac{LQg}{EAR} = \frac{(1.5 \text{ m})(9.8 \text{ m/s}^2)}{(6.89 \times 10^{10} \text{ N/m}^2)(\pi \times 10^{-4} \text{ m}^2)(0.3 \text{ m/s})} Q = 2.26 \times 10^{-6} Q$$

Now we can construct a table of flow to strain to GF to resistance change to bridge off-null voltage to output voltage:

Flow (kg/s)	Strain (μ)	GF	$ \Delta R $	ΔV	V
0	0	-160	0	0	0
25	-56.5	-140	2.37	.010	1.92
50	-113	-125	4.24	.018	3.46
75	-169.5	-109	5.54	.023	4.42
100	-226	-95	6.44	.027	5.19
125	-271.2	-85	6.92	.029	5.58
150	-339	-71	7.22	.030	5.77
175	-395.5	-59	7.00	.029	5.58
200	-452	-50	6.78	.028	5.38

The following plot shows that the output voltage varies non-linearly with flow.

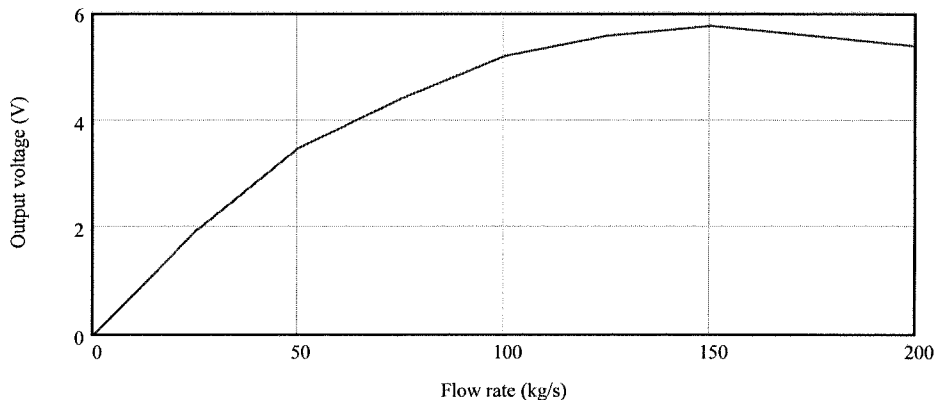

Furthermore because of the combined nonlinearity of the bridge and the gauge factor the output voltage is double valued for some flow rates. Not a good measurement system.

S5.4

(a) The pressure of is given by $p = \rho gh = (1 \text{ gm/cm}^3)(10^3 \text{ kg/gm})(10^{-6} \text{ cm}^3/\text{m}^3)(9.8 \text{ m/s}^2)(1 \text{ m}) = 9.8 \text{ kPa}$

If the liquid specific gravity (SG) varies from 1 to 2 then the liquid pressure varies from 9.8 kPa to 19.6 kPa.

(b) The output voltage of the sensor depends upon the difference in pressure,

$$V_s = 0.045(p_L - p_w) = (0.045 \text{ V/kPa})(p_L - 9.8 \text{ kPa}) = 0.045(\text{SF} - 1)9.8 \text{ V}$$

$$V_s = 0.441(\text{SG} - 1) \text{ V}$$

So the output voltage varies from 0 to 0.441 volts.

(c) The 8-bit ADC with a 5.0 volt reference will change from FEH to FFH at 4.98 volts. Therefore if the output is to be FFH at $\text{SG} = 2$, we form the relation, $4.98 = K(0.441)(2 - 1)$ so the gain, $K = 11.29$. The signal conditioning can thus be a simple non-inverting amplifier with a gain of 11.29.

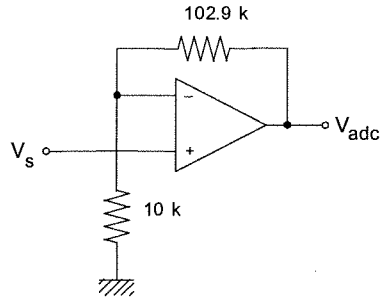

(d) The digital resolution is simply given by 1 part in 256 of the SG span of 1.0 to 2.0, so it is 0.0039.
 (e) An error in ± 2 cm in level represents a $\pm 2\%$ error since the level is nominally 1 m. The relation between SG and ADC voltage is, $SG = 1 + V_s/4.98$ and V_s varies as the inverse of the level so that we have, $V_s = V_s/(1 \pm 0.02) \approx V_s(1 \pm .02)$ therefore $SG = SG(1 \pm .02)$ and so this error in the level system will result in a $\pm 2\%$ error in SG measurement.

S5.5

We want to operate the filaments at 80°C using self-heating so we can estimate how much power must be dissipated in the filaments by $P = P_D \Delta T = (30 \text{ mW}/^\circ\text{C})(60^\circ\text{C}) = 1.8 \text{ W}$. Now we find the resistance of the filament at 80°C : $R(80^\circ\text{C}) = 20 \Omega [1 + 0.035(80 - 20)] = 62 \Omega$.

In order to dissipate 1.8 W in a 62Ω resistor we need a voltage of $V = (RP)^{1/2} = [(62)(1.8)]^{1/2} = 10.5 \text{ V}$. Let's use a 24 V source for a bridge into which the two filaments are placed. Then the other bridge resistors must be, $P = (24 - 10.5)/(10.5/62) \approx 80 \Omega$. Thus we use a bridge like Figure 2.5 with the upper resistors 80Ω each and the lower resistors the filaments.

The bridge off-null voltage is given by:

$$\Delta V = 24 \left[\frac{62}{62+80} - \frac{R}{R+80} \right] = 24 \left[0.4366 - \frac{R}{R+80} \right]$$

where R is given by $R = 20[1 + 0.035(T - 20)]$ and the temperature is given by Figure 5.51.

A table of pressure to temperature to resistance to voltage follows:

Pressure	Temperature	Resistance	Voltage
0	140	104	3.09
10	138	102.6	3.00
20	135	100.5	2.88
30	127	94.9	2.54
40	113	85.1	1.89
50	100	76	1.21
60	92	70.4	0.76
70	88	67.6	0.51
80	84	64.8	0.26
90	82	63.4	0.13
100	80	62	0

The following plot shows that the result is highly non-linear.

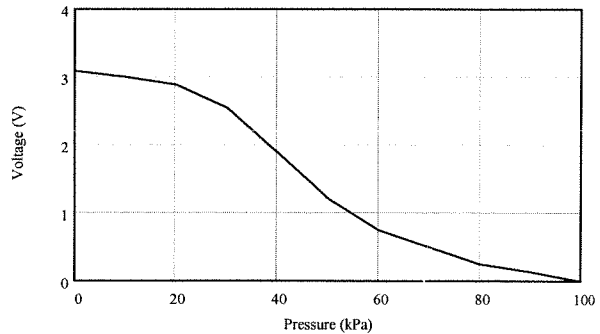

CHAPTER 6

6.1

$$f = c/\lambda = (3 \times 10^8 \text{ m/s})/(3 \times 10^{-2} \text{ m})$$

$$f = 10^{10} \text{ Hz which is in the microwave band}$$

6.2

$$\lambda = c/f = (3 \times 10^8 \text{ m/s})/(6.5 \times 10^{14} \text{ Hz})$$

$$\lambda = 4.62 \times 10^{-7} \text{ m}$$

$$\lambda = 0.462 \mu\text{m} = 462 \text{ nm} \quad (1 \text{ \AA} = 10^{-10} \text{ m}) \quad \text{so,}$$

$$\lambda = 4620 \text{ \AA}$$

6.3

Without the liquid the speed is $c = 3 \times 10^8 \text{ m/s}$
so the time is,

$$t = l/c = (100 \text{ m})/(3 \times 10^8 \text{ m/s})$$

$$t = 0.33 \mu\text{s}$$

With liquid the speed is $v = c/1.7$ so the time is 1.7 times greater,

$$t_l = 1.7t = (1.7)(0.33 \mu\text{s})$$

$$t_l = 0.57 \mu\text{s}$$

6.4

The following diagram shows how the beam spreads as it moves away from the source,

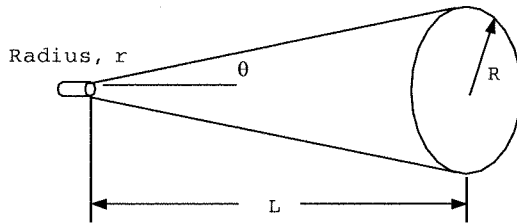

At a distance L the new radius is,

$$R = r + L \tan(\theta)$$

so, $r = 2 \text{ cm} = 0.02 \text{ m}$, $L = 60 \text{ m}$ and $\theta = 1.2^\circ$,

$$R = 0.02 + 60 \tan(1.2^\circ)$$

$$R = 1.277 \text{ m}$$

The size of the beam at 60 m is thus a circle of radius 1.277 m or diameter of 2.554 m.

The intensity is $I = P/A$. If we assume no loss in power over the 60 meters then,

$$A = \pi R^2 = \pi(1.277)^2 = 5.12 \text{ m}^2 \text{ so,}$$

$$I = 100 \text{ mW}/(5.12 \text{ m}^2)$$

$$I = 19.5 \text{ mW/m}^2$$

6.5

The surface area of a sphere at a distance R , is given by $A = 4\pi R^2$ so that the intensity is,

$$I_L = P/A = P/4\pi R^2$$

Solving for R ,

$$R = [P/4\pi I_L]^{1/2} = [10/(4\pi 25 \times 10^{-3})]^{1/2} \quad R = 5.64 \text{ m}$$

6.6

Well, let's see, we know that a 1 cd source puts 1/683 watts of power into any section of surface area at a distance R , which has an area of R^2 . (See Figure 6.7) Now, the total surface area of a sphere of radius R is given by $A = 4\pi R^2$, therefore the the total number of watts must be,

$$P = (4\pi R^2/R^2)(1/683) = 4\pi/683 \text{ W}$$

$$P = 18.4 \text{ mW}$$

6.7

The relation for radius of a beam of divergence θ at a distance L is given by,

$$R = r + L \tan(\theta)$$

where r is the source radius. The distance will first be converted to meters,
 $L = (2.38 \times 10^5 \text{ miles})(5.28 \times 10^3 \text{ ft/mile})(12 \text{ in/ft})(0.0254 \text{ m/in}) = 3.83 \times 10^8 \text{ m}$
 now the radius at the moon is found as,
 $R = 0.02 \text{ m} + (3.83 \times 10^8 \text{ m})\tan(3 \times 10^{-5}) = 1.15 \times 10^4 \text{ m}$ or a diameter of 23 km.
 The intensity is simply, $I = P/A = P/(\pi R^2) = 1000/[\pi(1.15 \times 10^4)^2] = 2.4 \text{ mW/m}^2$. This can also be expressed as 0.024 W/cm^2 which is an easily detectable intensity.

6.8

The intensity in the beam is given by:

$$I = P/A = P/(\pi D^2/4) = 2 \times 10^{-4} \text{ W}/[\pi(5 \times 10^{-2})^2/4] = 0.102 \text{ W/m}^2$$

Each photon carries an energy given by,

$$E_v = hf = hc/\lambda = (6.63 \times 10^{-34} \text{ J-s})(3 \times 10^8 \text{ m/s})/(700 \times 10^{-9} \text{ m}) = 2.84 \times 10^{-19} \text{ J}$$

so for the given intensity, as $W = \text{J/s}$ we have a number of photons per second per meter squared given by,

$$I_N = [0.102 \text{ (J/s)/m}^2]/2.84 \times 10^{-19} \text{ J} = 3.59 \times 10^{17} \text{ photons/(s-m}^2)$$

Thus the number striking the detector of area $A_d = \pi d^2/4 = \pi(2 \times 10^{-3} \text{ m})^2/4 = 3.14 \times 10^{-6} \text{ m}^2$ is given by,

$$N = [3.59 \times 10^{17} \text{ photons/(s-m}^2)](3.14 \times 10^{-6} \text{ m}^2) = 1.13 \times 10^{12} \text{ photons/second}$$

6.9

The first-order time response is given by,

$$R(t) = R_i + (R_f - R_i)[1 - e^{-t/\tau}]$$

thus,

$$R(t) = 150 + (45 - 150)[1 - e^{-t/73}]$$

at 20 ms we get,

$$R(20 \text{ ms}) = 150 - 105[1 - e^{-20/73}]$$

$$R(10 \text{ ms}) = 124.8 \text{ k}\Omega$$

After the pulse passes the resistance will begin to grow exponentially as,

$$R(t) = 124.8 + (150 - 124.8)[1 - e^{-(t-20)/73}]$$

The following figure shows the variation in resistance as the pulse passes.

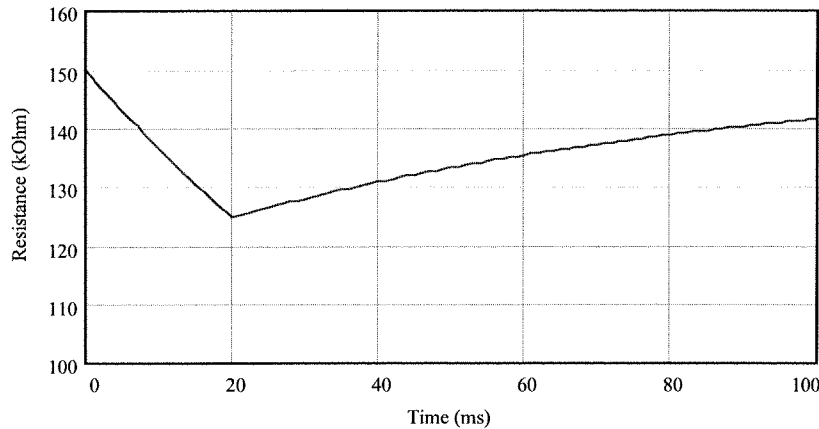

6.10

First we need a system which will discriminate between pulses and then a logic circuit to provide the correct LED operation. The following diagram shows the essential elements of the system.

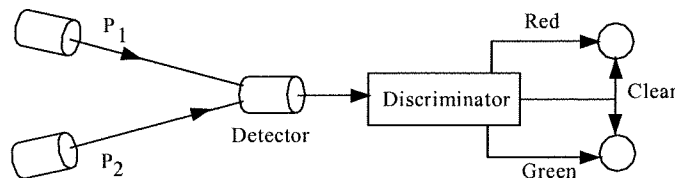

Let us find the magnitude of the cell resistance for each pulse. This means finding the resistance 20 ms after the pulse arrives. We know $R_{dark} = 150 \text{ k}\Omega$ and for P_1 the final resistance is $85 \text{ k}\Omega$ and for P_2 it is $45 \text{ k}\Omega$. Thus the resistance at 20 ms for each case is,

$$R_1 = 150 + (85 - 150)[1 - e^{-20/73}] \text{ k}\Omega = 134.4 \text{ k}\Omega$$

$$R_2 = 150 + (45 - 150)[1 - e^{-20/73}] \text{ k}\Omega = 124.8 \text{ k}\Omega$$

For a discriminator we can use comparators set to trigger at voltages corresponding to one pulse or the other. Another comparator can be used to clear the LEDs when any pulse is detected. To do this we will use a divider to convert cell resistance to voltage. As the figure below shows we use a $150 \text{ k}\Omega$ so that the 5 volt source is split when the cell is dark ($150 \text{ k}\Omega$), i.e., $V_D = 2.5$ volts dark and then increases.

For P_1 the divider voltage, and therefore comparator trigger voltage, will be,

$$V_1 = (150/(134.4+150))5 = 2.637 \text{ volts}$$

For P_2 the corresponding voltage is,

$$V_2 = (150/(124.8+150))5 = 2.729 \text{ volts}$$

For the clear we just select a trigger of 2.52 volts. This way when any pulse strikes the detector the LED's are first cleared in preparation for determination of which pulse arrived. The dividers and comparators in the circuit below show the connections. For the logic circuit, if you get only P_2 the one LED lights, if you get both P_2 and P_1 then the other LED lights. The one-shot outputs a clear pulse which should be short compared to 20 ms, say 1 ms.

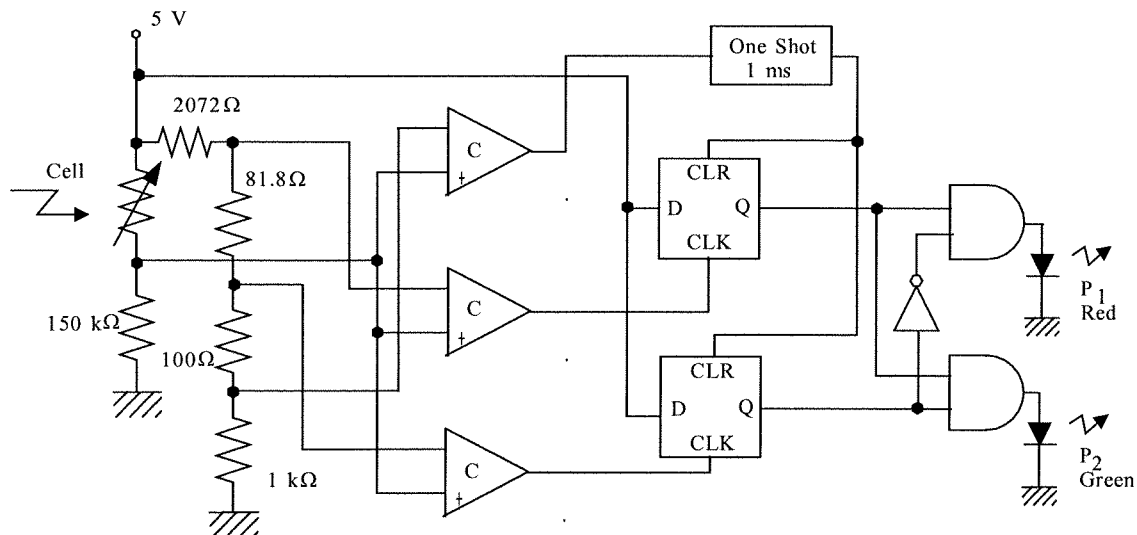

6.11

Ok, the photoconductive cell responds to the intensity, so we need to find the intensity as a function of distance from the source. The intensity at the sensor is given by,

$I_s = P/A = P/\pi R^2$ where $P = 75 \text{ mW}$ and R is the beam radius at the sensor. The radius is found from,

$$R = r + x \tan \theta \quad \text{where } r = 0.5 \text{ cm and } \theta = 2 \text{ mr}$$

so,

$$I_s = P/[\pi(r + x \tan \theta)^2] = 75 \text{ mW}/[\pi(5 \times 10^{-3} \text{ m} + x \tan(2 \times 10^{-3}))^2]$$

$$I_s = 23.87/(0.005 + 0.002x)^2 \text{ mW/m}^2 \quad x \text{ in m.}$$

Expressing this in mW/cm^2 we write $\text{m}^2 = 10^4 \text{ cm}^2$

$$I_s = 23.87/(0.5 + .002x)^2 \text{ mW/cm}^2 \quad x \text{ in cm.}$$

We now compute values of I_s for x varying from 0 to 250 cm and find the corresponding resistance from the graph of Figure 6.9.

x	0	25	50	75	100	125	150	175	200	225	250
I_s	95.5	78.9	66	56.5	48.7	42.4	37.3	33.0	29.5	26.4	23.87
R	0.6	0.8	1.1	1.4	1.6	1.8	2.0	2.2	2.3	2.5	2.7

The following graph shows sensor resistance versus light intensity.

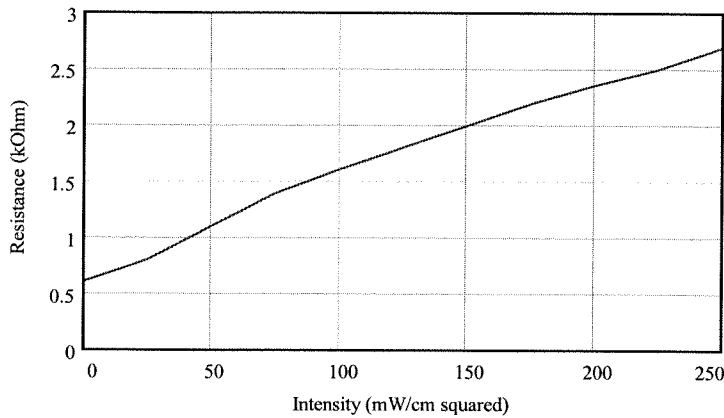

6.12

If we just ignore the nonlinearity then we form an equation between cell resistance and desired output voltage,

$$V_{out} = mR_C + V_0$$

From the graph we find that $R_C = 2.9 \text{ k}\Omega$ at 20 mW/cm^2 and $0.5 \text{ k}\Omega$ at 100 mW/cm^2 . Thus we form two equations,

$$1.0 = m(0.5 \text{ k}\Omega) + V_0$$

$$0.2 = m(2.9 \text{ k}\Omega) + V_0$$

Solving these we find $m = -(0.8/2.4 \text{ k}\Omega)$ and $V_0 = 1.1667 \text{ V}$ so that the equation is,

$$V_{out} = -(0.8/2.4 \text{ k}\Omega)R_C + 1.1667$$

This can be implemented with an inverting amplifier for the first stage with the sensor in the feedback, a $2.4 \text{ k}\Omega$ resistor on the input and a fixed -0.8 volt source (from a divider) on the input. This is followed by a summing amplifier with a constant -1.1666 volts on one input and the output of the first amplifier on the other input.

Testing this we find that for an intensity of 60 mW/cm^2 the resistance is $1.25 \text{ k}\Omega$. The equation gives a result of 0.75 volts , but it should be 0.6 volts . Thus a 25% error occurs because of the strong nonlinearity of the cell resistance versus intensity. In fact the following graph shows the desired output versus intensity and the actual.

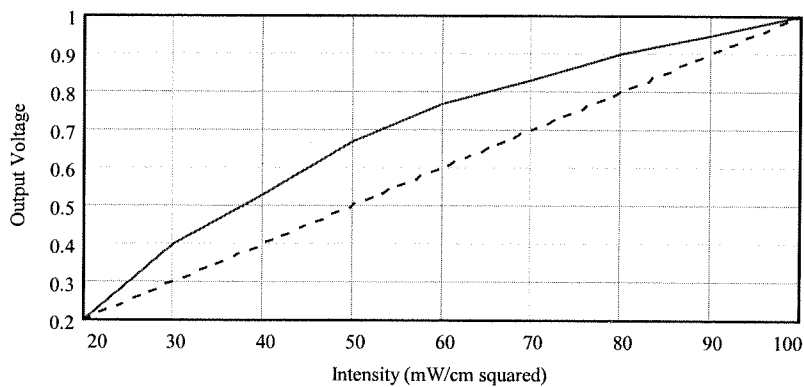

The point here is that you cannot use such a nonlinear sensor to make a linear display.

6.13

Well, the cell voltage is found from,

$$V = V_0 \ln(1 + I_L) = 0.6 \ln(1 + 2) = 0.659 \text{ V}$$

Since the inverting amplifier input resistance is only 100Ω and the cell internal resistance is 65Ω it is clear that there will be loading. The modeled circuit is now,

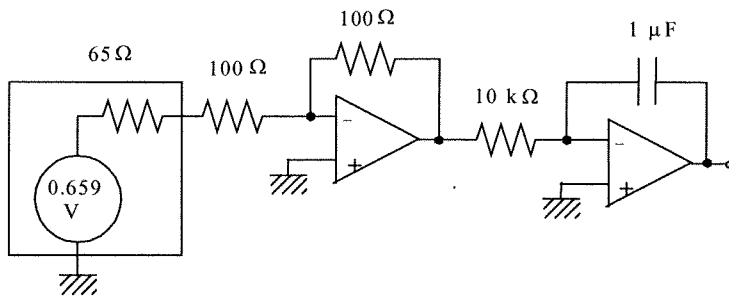

The actual input voltage, V_c , is given by the 0.659 divided between 65 Ω and 100 Ω,

$$V_c = 0.659(100/165) = 0.399 \text{ V} \approx 0.4 \text{ V}$$

Since the inverting amplifier has a gain of -1, the input of the integrator is -0.4 volts. Thus the output voltage is given by,

$$V_{out} = -\frac{1}{(10\text{k}\Omega)(1\mu\text{F})} \int (-0.4) dt$$

$$V_{out} = 40t \text{ volts}$$

The output rises at 40 V/s during the 20 ms pulse. The following sketch shows the relation between the output and input. Note that the maximum output is 0.8 volts at 20 ms.

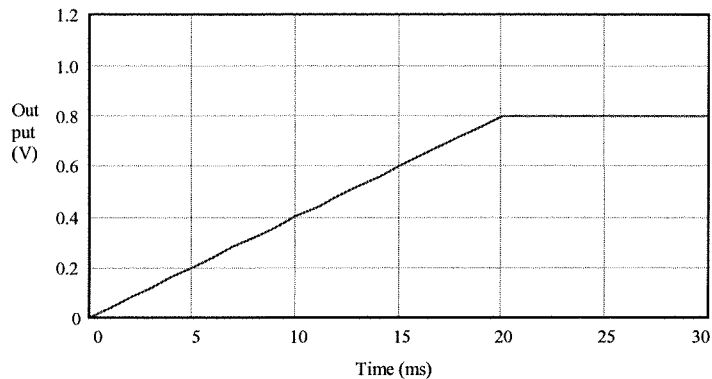

6.14

We need to put cells in series and parallel until we get the required voltage and power. Since the load power is 500 mW at 9.0 volts we find the load resistance from $P = V_L^2/R_L$,

$$R_L = V_L^2/P = 81/0.5 = 162 \Omega$$

The cell internal resistance is found from the open circuit voltage and short circuit current,

$$R = 0.6/0.015 = 40 \Omega$$

Then we model each cell by a 0.6 volt source in series with a 40 Ω resistor. Let's assume n-parallel combinations of m-cells in series. We need the Thevenin equivalent circuit,

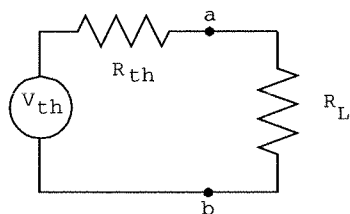

To find this we draw the actual model and first show that it can be reduced to a parallel combination of mR resistance in series with an mV voltage source, as

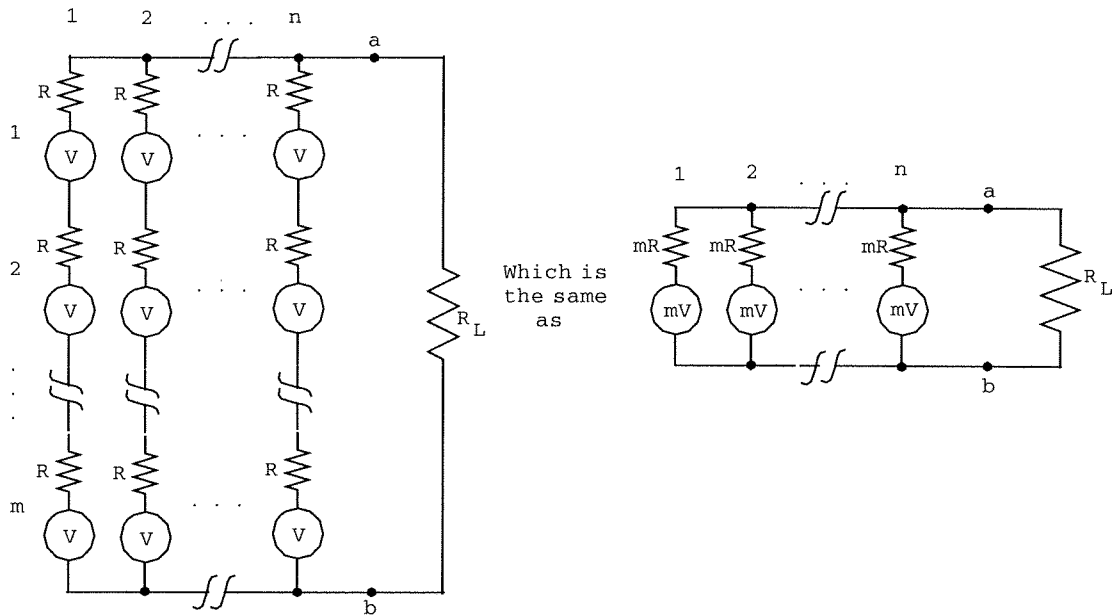

For optimum power delivery we need the Thevenin equivalent circuit of the cell system to have $R_{th} = R_L$ and $V_{th} = 2V_L$. The resistance is simply the resistance from $a-b$ with the voltages replaced by short circuits, Thus,

$$\frac{1}{R_{th}} = \frac{1}{mR} + \frac{1}{mR} + \dots + \frac{1}{mR} = \frac{n}{mR} \quad \text{so} \quad R_{th} = \frac{mR}{n}$$

To find V_{th} we note that since each element in parallel is the same it is clear that $V_{th} = mV$. Thus $m = V_{th}/V = 2V_L/V = 18/0.6 = 30$. Then from the resistance result, $n = mR/R_{th} = mR/R_L = (30)(40)/162 = 7.4$ so we use $n = 8$. Therefore we need 8-parallel combinations of 30 cells in series.

It should be noted that the internal resistance of the cell under load and no-load is not constant so the 40Ω short circuit value will not be correct under the given load conditions. Thus this solution should give an approximate solution, but not exact.

6.15

Let's use a $25 \text{ k}\Omega$ resistor in series with the diode, as in Figure 6.18. A load line will extend from $-1 \mu\text{A}$ to -25 volts in Figure 6.16. This will result in a current range of $-200 \mu\text{A}$ at 100 W/m^2 to $-800 \mu\text{A}$ at 400 W/m^2 . The output of the first stage op amp circuit (again using Figure 6.18), will thus be a voltage, V_a , of -0.2 to -0.8 volts. Now, this voltage range must interface with the 10-bit, bipolar ADC with a 5 volt reference. The design requires an output of 100_{10} when the intensity is 100 W/m^2 and 400_{10} when the intensity is 400 W/m^2 so the ADC output is numerically equal (base 10) to the intensity. It could thus be displayed directly for example.

For the ADC we have a relation, $N = [V_{ADC}/V_R + 1/2]2^n = [V_{ADC}/5 + 0.5]1024$ From this we can find what input voltages are required for 100_{10} and 400_{10} outputs, as,

$$100 = [V_1/5 + 0.5]1024 \quad \text{and} \quad 400 = [V_2/5 + 0.5]1024$$

from which $V_1 = -2.0117$ and $V_2 = -0.5469$. From these we can find an equation for the required signal conditioning, $V_{ADC} = mV_a + V_0$

$$-2.0117 = -0.2m + V_0$$

$$-0.5469 = -0.8m + V_0$$

Solving we find $m = -2.44$ and $V_0 = -2.5$ so that $V_{ADC} = -2.44V_a - 2.5$. This can be implemented by a summing amplifier. The following circuit will satisfy the need.

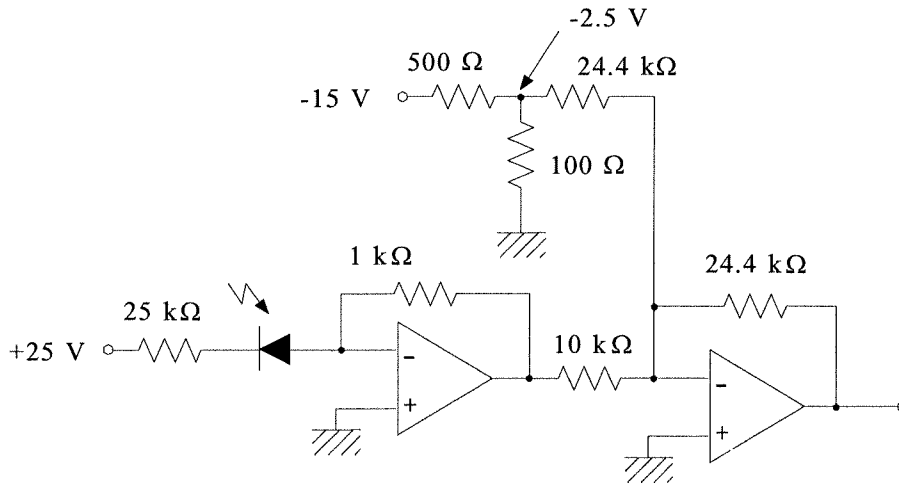

6.16

There will be a collector-emitter current determined by the light intensity and a load line on the transistor curves of Figure 6.20. To find the load line we consider the $10\ \Omega$ and $100\ \Omega$ resistors in the emitter to be in parallel to ground, thus we have $420I_c + V_{ce} + 9.09I_c = 10$, or $429.09I_c + V_{ce} = 10$. When $I_c = 0$ we have $V_{ce} = 10$ and when $V_{ce} = 0$ we have $I_c = 10/429.09 = 23.3\ \text{mA}$. The load line extends from 10 volts on the V_{ce} axis to 23.3 mA on the I_c axis. From this load line the collector currents corresponding to 10, 20, 30, and 40 mW/cm^2 can easily be found. This current is divided between the $10\ \Omega$ and $100\ \Omega$ resistors with a fraction $10/110 = 0.091$ going through the $100\ \Omega$ resistor. This current will be balanced by feedback through the $500\ \Omega$ resistor. Thus the output voltage will be,

$$V_{out} = -500(10/110)I_c = -45.45I_c$$

The following table summarizes these results

Intensity (W/m^2)	Collector current (mA)	Output voltage (volts)
10	4	-0.18
20	7.9	-0.36
30	10.5	-0.47
40	14	-0.64

The following plot shows how the voltage varies with light intensity.

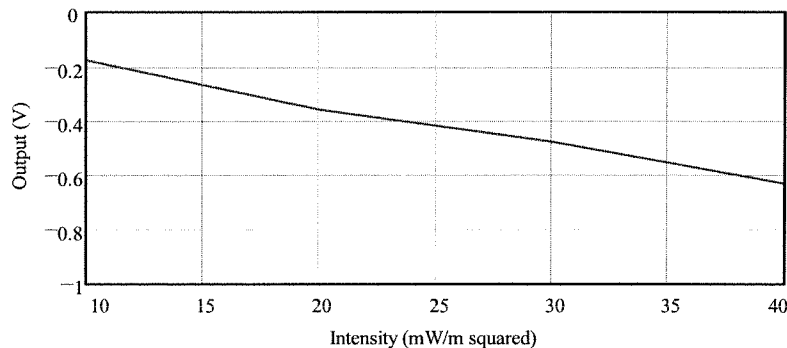

6.17

We use the phototransistor in a circuit like Figure 6.19 to obtain a voltage which varies with light intensity. In fact from Example 6.10, with $R_c = 500\ \Omega$ and a 14 volt supply we find that a 20 mW/cm^2 intensity produces a voltage of 10 volts from the load line of Figure 6.20. Therefore we need a comparator with a 10 volt trigger, but note that the voltage decreases with increasing light intensity. This means that the +10 V must be on the + terminal of the comparator. So when it is dark the phototransistor voltage is large and the comparator output is low. As the intensity

increases the phototransistor voltage drops until, below 10 V, the comparator goes high. The following circuit will satisfy this need.

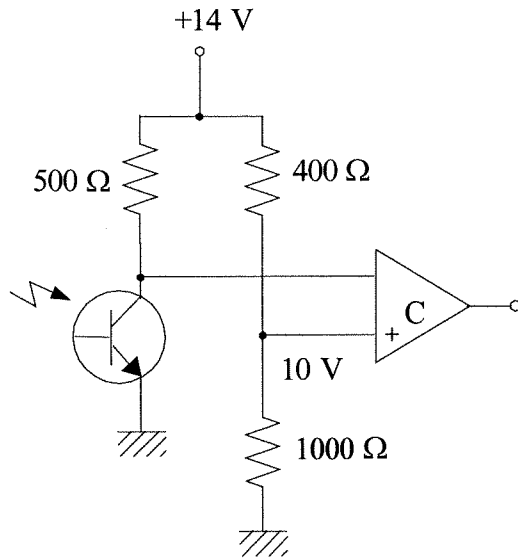

6.18

We need the resistance, R , so that $V_{out} = IR = 3 \mu\text{V}$. The current is found from the gain of the PM tube and the charge of an electron. So,

$$I = (3 \times 10^6)(50 \text{ e/s})(1.6 \times 10^{-19} \text{ C/e})$$

$$I = 2.4 \times 10^{-11} \text{ A} \quad (1 \text{ A} = 1 \text{ C/s})$$

thus,

$$R = V/I = 3 \times 10^{-6} / 2.4 \times 10^{-11}$$

$$R = 125 \text{ k}\Omega$$

6.19

The intensity is given by $I_L = P/A$. If the diameter is 1 mm then the area is,

$$A = \pi(10^{-3})^2/4 = 7.85 \times 10^{-7} \text{ m}^2$$

Thus, the intensity is given by,

$$I_L = 10 \text{ W} / 7.85 \times 10^{-7} \text{ m}^2$$

$$I_L = 1.27 \times 10^7 \text{ W/m}^2 \text{ !!!}$$

6.20 The system under consideration is,

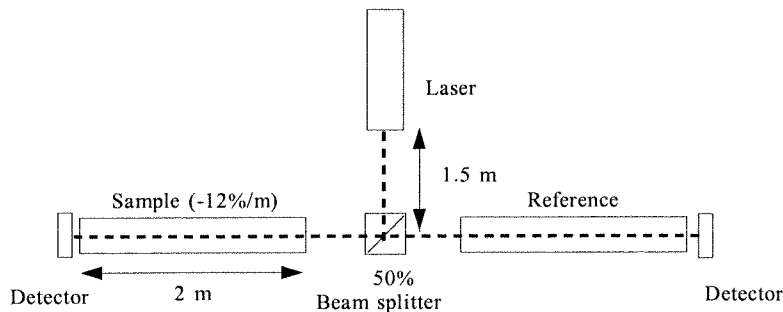

All the mirrors only change direction and do not change the divergence. The beam splitter simply halves the power. Thus we are reduced to a simple beam divergence problem but with a further reduction in beam power of 12 %/m in the sample.

Thus, $R = r + L \tan(\theta)$

$$R = 10^{-3} \text{ m} + 3.5 \tan(2.2 \times 10^{-3}) \text{ m}$$

$$R = 8.7 \text{ mm}$$

The area of the beam at this radius is given by,

$$A = \pi R^2 = \pi(8.7 \times 10^{-3} \text{ m})^2$$

$$A = 2.38 \times 10^{-4} \text{ m}^2$$

The total power at the detector is half the source, 1.05 mW, reduced by 12 %/m by the 2 m tank,
 $P = 1.05 - 0.12(2)(1.05) = 0.798 \text{ mW}$

so the intensity is given by,

$$I_L = P/A = 0.798 \text{ mW}/2.38 \times 10^{-4} \text{ m}^2$$

$$I_L = 3.35 \text{ W/m}^2$$

6.21

Since $x = ct$, we have

$$x = (3 \times 10^8 \text{ m/s})(2.4 \times 10^{-9} \text{ s})$$

$$x = 0.72 \text{ m}$$

6.22

There are many ways to do this. The most straight forward is to use dividers to convert the photocell resistance changes to voltages, find the difference and trigger a comparator if the difference exceeds a value for a 10 % intensity reduction.

The graph of resistance versus intensity shows that the resistance at 15 mW/cm^2 is about $3.6 \text{ k}\Omega$. A 10% reduction to 13.5 mW/cm^2 results in an increase of resistance to about $4.4 \text{ k}\Omega$.

We simply pick divider resistance shown in the circuit below, R_1 and R_2 , to be $20 \text{ k}\Omega$ each. Any other reasonable value could be used. At the nominal intensity of 15 mW/cm^2 the two divider voltages will be the same,

$$V_1 = V_2 = (15)(3.6)/(20+3.6) = 2.288 \text{ V}$$

The differential amplifier output will be zero and the alarm comparator is not triggered.

If the flow intensity reduces there will be a differential amplifier output to indicate this. If it changes by 10% then that divider voltage will increase to,

$$V_2 = (15)(4.4)/(20+4.4) = 2.705 \text{ V}$$

so that the voltage difference is $\Delta V = 0.417 \text{ V}$. If we pick the comparator trigger voltage to be 5 volts, then the differential amplifier must have a gain of,

$$(R_4/R_3) = 5/0.417 = 11.97$$

Thus values of $R_3 = 1 \text{ k}\Omega$ and $R_4 = 11.97 \text{ k}\Omega$ will suffice.

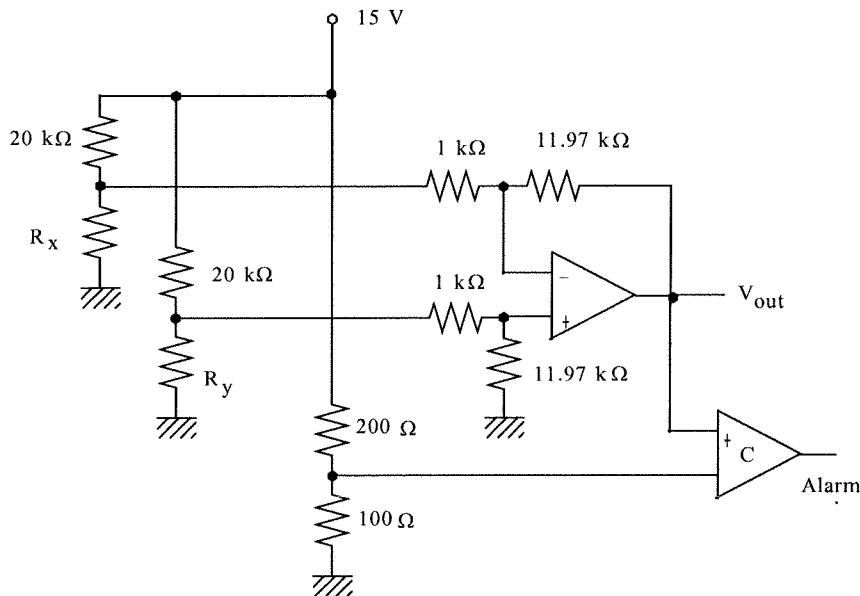

Supplementary Problems

S6.1

(a) Using the circuit of Figure 6.16a we see that the voltage across the diode can be written in the form:

$$V_D = 20 - 15000I$$

The current is dependent on light intensity by the given relation of,

$$I = 1.429I_L + 57 \mu\text{A}$$

where I_L is the light intensity in W/m^2 . Light intensity is given by the relation,

$$I_L = P/A$$

where P is the light power in W and A the beam area in m^2 . The area is dependent upon the distance by the expanding radius given by the divergence relation,

$$R = r + L\tan(\theta)$$

where r is the original laser radius, L the distance from the laser and θ the divergence angle.

When this is all put together we will have a diode voltage which depends upon distance from the source.

Working backwards,

$$R = 0.005 + L\tan(0.2 \text{ rad}) = 0.005 + 0.00349L$$

The area is $A = \pi R^2$ so the intensity is,

$$I_L = \frac{0.06}{\pi(0.005 + 0.00349L)^2}$$

So, the diode current is given by,

$$I = \frac{0.08574}{\pi(0.005 + 0.00349L)^2} + 57 \mu\text{A}$$

Finally the diode voltage is now given by,

$$V_D = 20 - 0.015 \left[\frac{0.08574}{\pi(0.005 + 0.00349L)^2} + 57 \right]$$

When the distance is $L = 0 \text{ m}$ we get $V_D = 2.77 \text{ V}$

When the distance is $L = 5 \text{ m}$ we get $V_D = 18.33 \text{ V}$

For an 8-bit ADC with a 10.0 V reference the last bit sets at 9.9609 volts. Therefore we now need signal conditioning that satisfies:

$$V_{ADC} = mV_D + V_0$$

$$0 = 2.77m + V_0$$

$$9.9609 = 18.33m + V_0$$

These equations give $m = 0.64$ and $V_0 = -1.773 \text{ V}$. This is cast in the form of a differential amplifier as,

$$V_{ADC} = 0.64(V_D - 2.77)$$

The following circuit will perform this conversion.

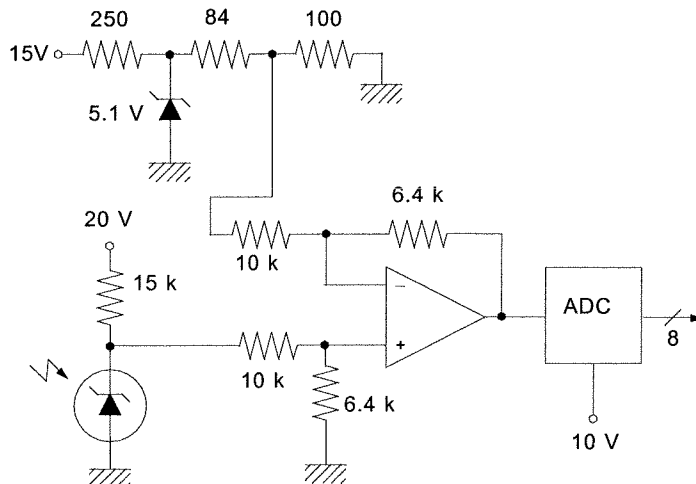

(b) The ADC output is given by $N = 256(V_{ADC}/10)$ where only the integer part is taken. The plot is:

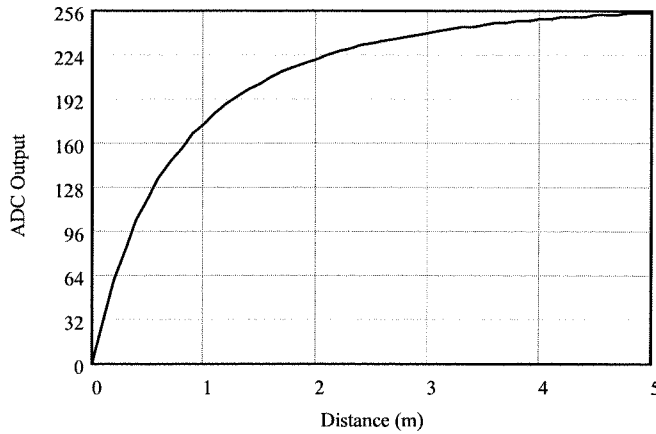

S6.2

Ok, let's assume the system has some kind of intrusion detector which provides a logic high when an intrusion occurs. Then there is a camera and a light, both triggered by a logic high. Finally there are a CdS cell and a photodiode both of which view the light in the room.

Figure 6.9 shows that the CdS cell resistance drops to $2.9 \text{ k}\Omega$ at 20 mW/cm^2 light intensity. So we need to convert this to a voltage and use the voltage as input to a comparator. The easiest thing to do is put the cell in a simple divider. We excite the divider with a 5.1 volt zener regulator and use a $3 \text{ k}\Omega$ resistor for the other resistor in the divider circuit. This makes the divider voltage at 20 mW/cm^2 ,

$$V_{20} = (5.1 \text{ V}) \frac{3 \text{ k}\Omega}{3 \text{ k}\Omega + 2.9 \text{ k}\Omega} = 2.59 \text{ V}$$

This comparator reference voltage can be provided by another divider. The output of this comparator should be ANDed with the intrusion detector with the output triggering the shutter if both are high.

If the ANDed signal is not high it should trigger the flash. The photodiode is then used in a circuit like that of Figure 6.18, but with the feedback resistor $5 \text{ k}\Omega$. At an intensity of 20 mW/cm^2 (which is the same as 200 W/m^2) this will make the output of the op amp 2.0 volts because the current will be $400 \mu\text{A}$. So a second comparator with a reference of 2.0 volts will detect when the intensity has reached 20 mW/cm^2 and serve to trigger the shutter. The following diagram shows the whole system.

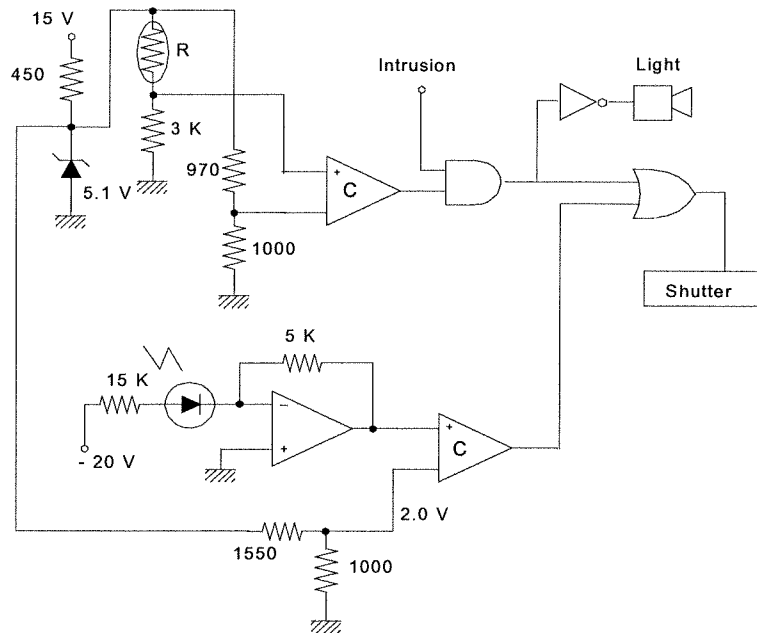

Of course the CdS cell is too slow to detect the intensity of the flash in enough time to trigger the shutter.

S6.3

We will convert the two photocell short circuit currents to voltages using an op amp. With a 100 w resistor in the feedback the output voltages will be $100/I_{sc}$. These two voltages will be amplified by a differential amplifier with a gain sufficient to produce ± 2.5 volts at the extremes of ± 1 cm.

To find the current and therefore input voltages at ± 1 cm we use the relation shown in the problem,

$$I_{sc}(\pm 1 \text{ cm}) = \left[2\pi - \frac{1 \mp 2}{8} \sqrt{15 \pm 4 - 4} - \sin^{-1} \left(\frac{1 \mp 2}{4} \right) \right] = 7.02 \quad \text{and} \quad 4.44 \text{ mA}$$

This means the voltages are 0.702 and 0.444 volts for the two extremes. Therefore the difference is $0.702 - 0.444 = 0.258$ volts. This must produce 2.5 volts on the output of the differential amplifier. So the needed gain is, $G = 2.5/0.258 \approx 9.7$. The following circuit satisfies the design.

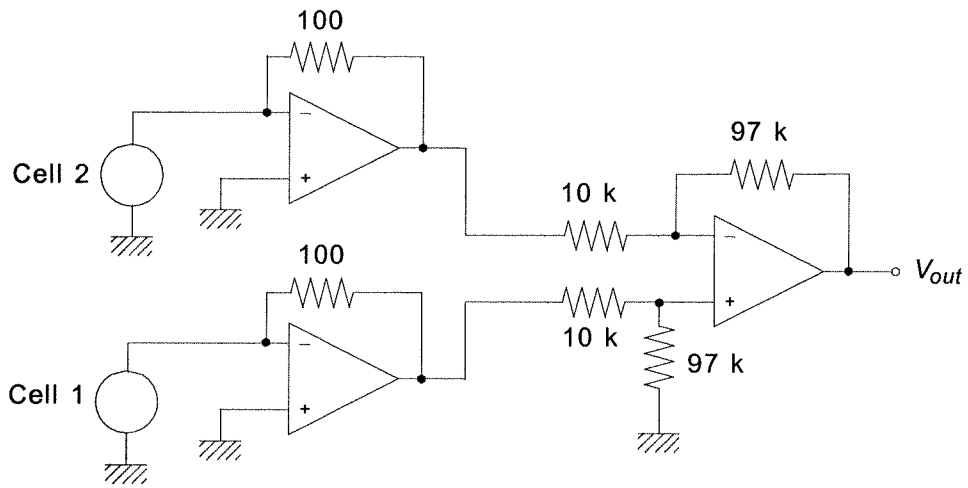

The response is slightly non-linear near the extremes as shown by the following plot.

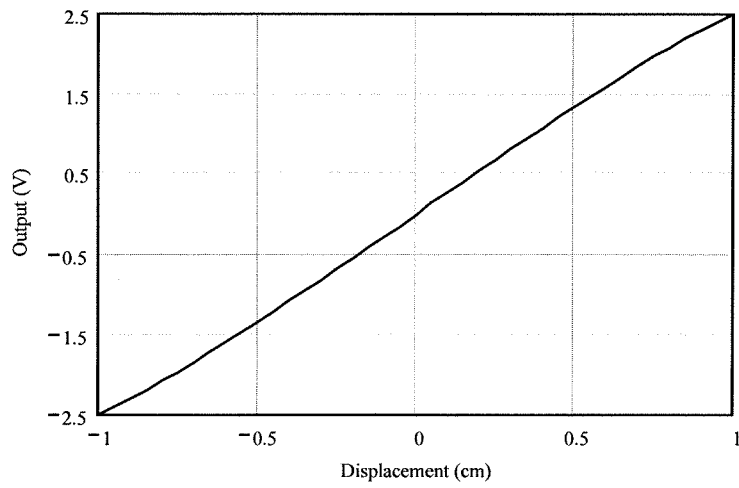

CHAPTER 7

7.1

The $100\ \Omega$ resistor provides $V_a = 100I$ so as I varies from 4 mA to 20 mA this voltage will vary from 0.4 to 2.0 volts. There must be a linear circuit that converts this voltage variation into 20 to 40 volts. So,

$$V_{out} = mV_a + V_0$$

Using the given conditions provides the equations,

$$20 = 0.4m + V_0$$

$$40 = 2.0m + V_0$$

subtracting,

$$20 = 1.6m \quad \text{or} \quad m = 20/1.6 = 12.5 \text{ then,}$$

$$20 = (0.4)(12.5) + V_0$$

$$V_0 = 20 - 5 = 15$$

so the box must provide,

$$V_{out} = 12.5V_a + 15$$

or, $V_{out} = 1250I + 15$ (I in amperes)

7.2

Since the power amplifier has a gain of ten, the equation above can be reduced by a factor of ten.

Using the voltage equation,

$$V_{out} = 1.25V_a + 1.5$$

or $V_{out} = 1.25(V_a + 1.2)$

This can be provided by a differential amplifier as follows,

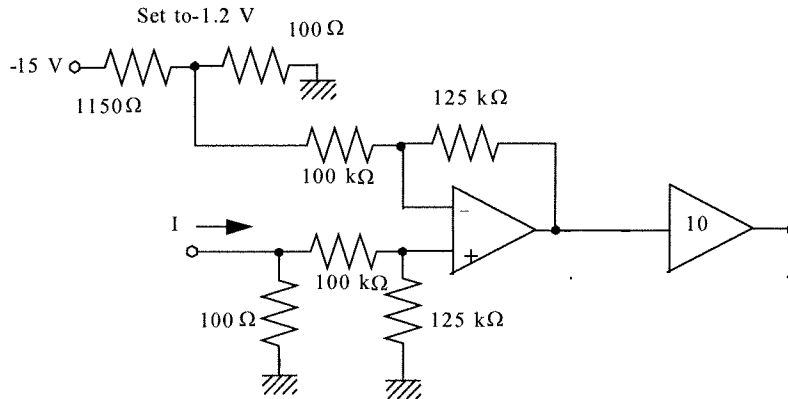

7.3

In block diagram we have,

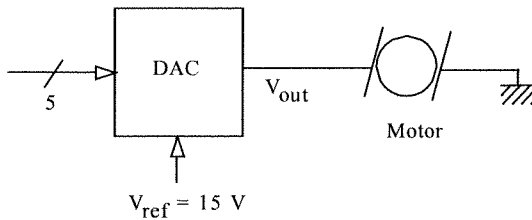

For the minimum rpm we have,

$$V_{out} = V_{ref}(b_12^{-1} + \dots + b_52^{-5})$$

or, $V_{out} = V_{ref}(N/2^5)$

$$5 = 15(N_{min}/2^5)$$

so, $N_{min} = 10.6$ or 10 or 01010_2

For the maximum rpm, $10 = 15(N_{max}/2^5)$ or,

$$N_{max} = 21.33$$
 or 21 or 10101_2

The speed change per LSB is found from the voltage of a LSB and the speed change per volt.

$$\Delta V = V_{ref}2^{-n} = (15)2^{-5} = 0.46875\text{ V}$$

thus, $\Delta R = (200\text{ rpm/V})(0.46875\text{ V})$

$$\Delta R = 93.75\text{ rpm/LSB}$$

7.4

Ok, when the square wave is on (+10 V) the capacitor will charge through R until its voltage reaches +2.5 volts. At that moment the SCR will turn on, discharging the capacitor and placing the 10 volts across the load (less any forward SCR on voltage drop, which we do not know). So what we need to know is when the voltage across the charging capacitor reaches 2.5 volts. The equation for charging the capacitor is given by,

$$V_C = V_0 \left[1 - e^{-t/RC} \right] \text{ where } V_0 = 10 \text{ (when on) and } C = 10 \mu\text{F}$$

(a) 5% on-time means that 2.5 volts must be reached at $0.95(2 \text{ s}) = 1.9 \text{ s}$ and 95% on-time means that 2.5 volts must be reached at $0.05(2) = 0.1 \text{ s}$. Thus we solve for the required R for each case. Solving the above equation for R gives,

$$R = -\frac{t}{C \ln(1 - V_C / V_0)}$$

Thus $R_5 = -\frac{1.9}{(10^{-5} \ln(1 - 2.5 / 10))} = 660 \text{ k}\Omega$ $R_{95} = -\frac{0.1}{(10^{-5} \ln(1 - 2.5 / 10))} = 34.8 \text{ k}\Omega$

(b) for a 50% on-time we have $t = 1.0 \text{ s}$ and $R = 347 \text{ k}\Omega$ so the capacitor voltage is given by, $V_C(t) = 10[1 - e^{-t/3.47}]$ then when the SCR is turned on the capacitor is discharged through the 100Ω resistor, so the voltage decreases according to:

$$V_C(t) = 2.5e^{-t/0.001}$$

The load voltage is zero for the first 1.0 second and 10 for the second 1.0 seconds that the voltage is 10 volts. The SCR is just the opposite. Thus,

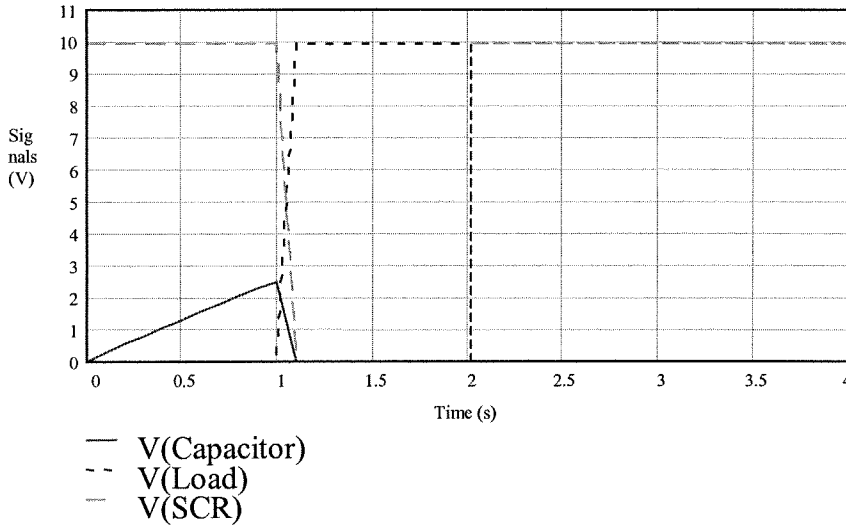

(c) The average power is just the fraction of on time to total time times the instantaneous power, $\langle P \rangle = t_{on}P/T = (t_{on}/T)V^2/R_L = (1/4)(10)^2/10 = 2.5 \text{ W}$

7.5

Now the system has the form:

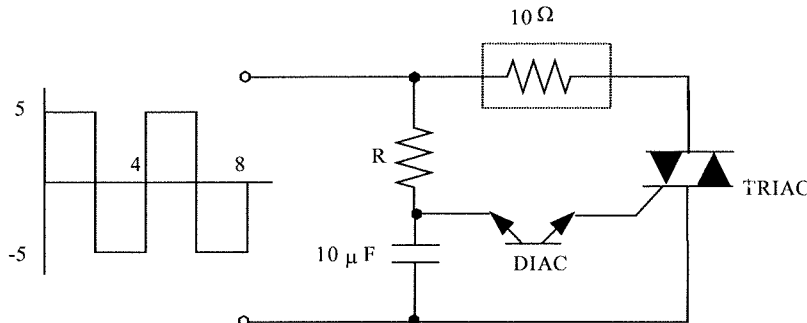

The charging of the capacitor is the same as the problem above except that the DIAC will start conducting at +2 and -2 volts. Thus we find values of $R = -t/[C \ln(1 - V_C/V_0)]$ with $C = 10 \mu\text{F}$, $V_C = \pm 2 \text{ V}$ and $V_0 = \pm 5 \text{ V}$.

(a) The range of R is,

$$5\% \text{ on-time: } t = 0.1 \text{ s, } R_{5\%} = 19.6 \text{ k}\Omega$$

$$95\% \text{ on-time: } t = 1.9 \text{ s, } R_{95\%} = 372 \text{ k}\Omega$$

(b) Using 50% as in the previous problem the capacitor, load and TRIAC voltages are:

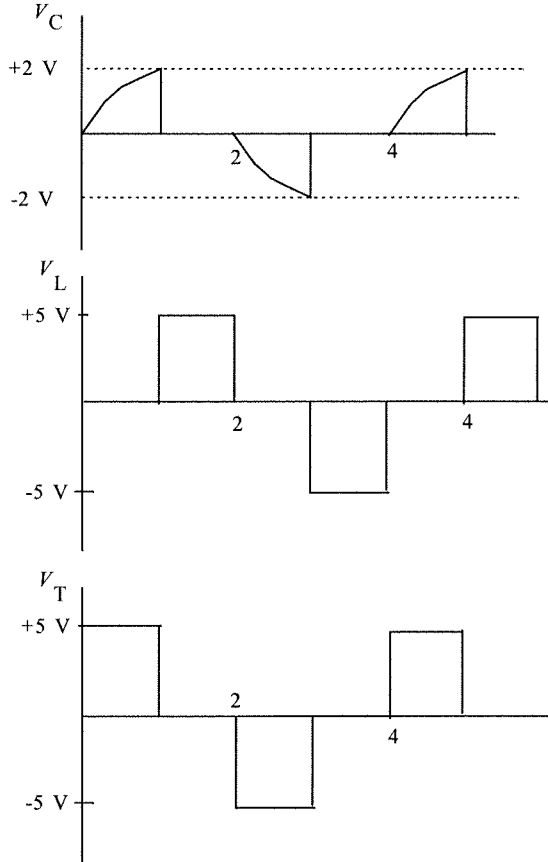

(c) The average power at 50% is again found as the fraction of the period for which the power is dissipated

$$\langle P \rangle = (t_{on}/T)V^2/R_L = (2/4)(5^2)/10 = 1.25 \text{ W}$$

7.6

Well, the resistance of the load is $R_L = 100 \Omega$ (about like a 100 W light bulb). From Example 7.3 we find the time at which the bulb turns on is given in terms of resistance as,

$$t_{on} = 0.511RC = 0.511(0.12 \mu\text{F})R = (6.132 \times 10^{-8})R \text{ s}$$

and R varies from 15 k Ω to 115 k Ω . Ok, we find the average power over one period by integration of the instantaneous power,

$$P_{av} = \frac{1}{T} \int_0^T p^2(t) dt$$

where we know $T = 1/60 = 16.67 \text{ ms}$. The instantaneous power is given by $p(t) = v^2(t)/R_L$. Example 7.3 showed us that the voltage across the load was zero until the SCR turned on and then was equal to the sine wave of the 120 vrms ac source voltage, $v_{ac}(t) = 169.7\sin(377t)$. Thus we conclude that the load voltage within one period is given by,

$$\begin{aligned} v(t) &= 0 && \text{for } t < t_{on} \\ v(t) &= 169.7\sin(377t) && \text{for } t_{on} < t < 8.33 \text{ ms} \\ v(t) &= 0 && \text{for } t > 8.33 \text{ ms (because the SCR is reverse biased)} \end{aligned}$$

Now the average power can be found,

$$P_{av} = \frac{1}{R_L T} \int_0^{T/2} v^2(t) dt = \frac{1}{(100)(16.67 \times 10^{-3})} \int_{t_{on}}^{0.00833} (169.7)^2 \sin^2(377t) dt$$

this can be simplified to

$$P_{av} = 45.82 \int_{t_{on}}^{0.00833} \sin^2(377t) d(377t) = 45.82 \left[\frac{377t}{2} - \frac{\sin(754t)}{4} \right]_{t_{on}}^{0.00833}$$

after substitution of the upper and lower limits and some simplification this becomes

$$P_{av} = 45.82 \left[188.5(0.00833 - t_{on}) + \frac{\sin(754t_{on})}{4} \right]$$

Finally, substituting for t_{on} from above we have,

$$P_{av} = 45.82 \left[188.5(0.00833 - 6.132R \times 10^{-8}) + \frac{\sin(4.62R \times 10^{-5})}{4} \right]$$

Plotting:

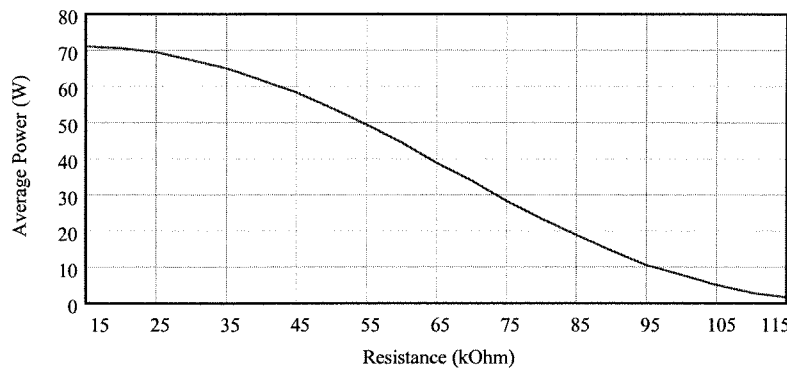

So the average power is not linearly related to the resistance because the ac signal is not linearly related to the time (i.e., it is a sinusoid).

7.7

(a) The voltage across the zener is essentially 5.1 volts at all times, falling briefly to zero only every period of the full-wave rectified signal. Thus the voltage across the capacitor will be given by the typical charging equation, $V_C(t) = 5.1[1 - e^{-t/\tau}]$ where $\tau = (R_T + R)C$. The SCR will fire when $V_C(t) = 1.5$ V so we can solve for the relation between t and τ ,

$$1.5 = 5.1[1 - e^{-t/\tau}] \text{ gives } t/\tau = -\ln[1 - 1.5/5.1] = 0.348$$

$$t = 0.348\tau = 0.348(R_T + R)C$$

At 0°C we want a 10% on-time which means that the time to reach 1.5 volts should be 90% of the period or $0.9(1/120) = 7.5$ ms. At 60°C we want a 90% on time which means that 1.5 volts should be reached in 10% of the period, $0.1(1/120) = 0.83$ ms. Figure 4.5 shows that at 0°C $R_T = 16$ k Ω and at 60°C $R_T = 1$ k Ω . Putting this all together we find two equations for R and C ,

$$0.0075 = 0.348(16000 + R)C$$

$$0.00083 = 0.348(1000 + R)C$$

Solving these simultaneous equations gives $R = 875 \Omega$ and $C = 1.28 \mu\text{F}$.

(b) The power ratings are found by the power dissipated by the resistor and the zener respectively. In the case of the resistor there is a voltage across its terminals of the average full-wave rectified voltage less the 5.1 V zener voltage. The average is given by,

$$\langle V \rangle = \frac{1}{T} \int_0^T V_0 \sin(377t) dt = \frac{(120)(169.7)}{377} \int_0^{1/120} \sin(377t) d(377t) = 54[-\cos(377/120) + \cos(0)] = 108 \text{ V}$$

$$P_R = (108 - 5.1)/2.5 \text{ k}\Omega = 4.23 \text{ W} \text{ so we need a 5 W power resistor.}$$

The current through the zener is the current through the 2.5 k Ω resistor, $I = (108 - 5.1)/2.5 \text{ k}\Omega = 41$ mA. Thus, $P_Z = (0.041 \text{ A})(5.1 \text{ V}) = 0.2 \text{ W}$ so a 1/2 W zener will suffice.

(c) The SCR turns on at a time t , given above, which depends upon the resistance, R , which depends on the temperature. The average voltage across the motor will thus be given by,

$$\langle V_M \rangle = \frac{1}{T} \int_0^T V_0 \sin(377t) dt = \frac{(120)(169.7)}{377} \int_0^{1/120} \sin(377t) d(377t) = 54[-\cos(377/120) + \cos(377t)]$$

substituting with $t = 0.348(R + 875)(1.28 \times 10^{-6}) = 4.45 \times 10^{-7}$ we get,

$$\langle V_M \rangle = 54[1 + \cos(1.68 \times 10^{-4}(R + 875))]$$

So, we look up the values of R for temperature between 0 and 60 °C and use this to find the average voltage from the equation above.

Temperature (°C)	Resistance (kΩ)	Voltage
0	16	2.5
10	10	40.3
20	6.5	71.6
30	4.5	87.4
40	3	97.0
50	2	101.8
60	1	105.3

A plot of voltage versus temperature provides,

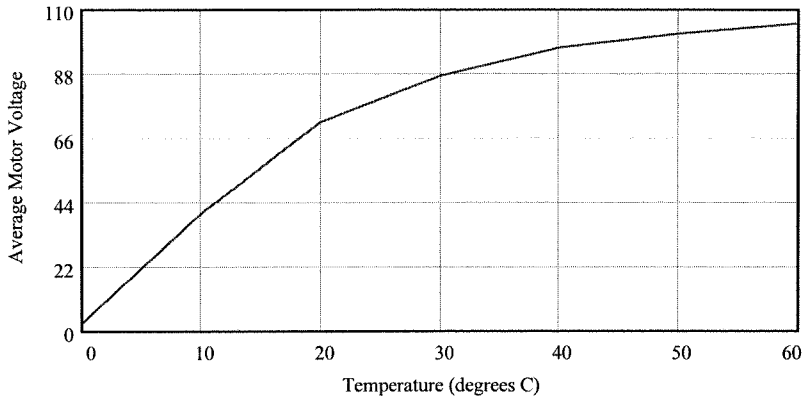

7.8

To get 10% and 90% on-time we need to find the values of R which will provide times to reach ± 28 V of 7.5 ms and 0.83 ms. We are given that $V_0 = 169.7$, $\omega = 377$ and $C = 0.12 \mu\text{F}$. After substituting these values into the equation for $V_C(t)$ we find the following two equations to be solved for R_{10} and R_{90} .

$$28 = \frac{169.7}{1 + (4.5R_{10} \times 10^{-5})^2} \left[0.31 + 4.5R_{10} \times 10^{-5} e^{-62500/R_{10}} + 4.28R_{10} \times 10^{-5} \right]$$

and

$$28 = \frac{169.7}{1 + (4.5R_{90} \times 10^{-5})^2} \left[0.31 + 4.5R_{90} \times 10^{-5} e^{-6944/R_{90}} - 4.28R_{90} \times 10^{-5} \right]$$

In principle we just solve for the two values of resistance, but in practice this cannot be done. A solution to whatever degree of accuracy is desired can be obtained graphically. In the following plot we graph the right hand side of the two functions above versus values of resistance and the constant 28. The value of resistance where the function crosses the 28 volt line is the solution. You can see that for R_{10} this is beyond 230 kΩ and for R_{90} it is less than 4 kΩ. The next two plots are with greatly expanded scales for the two functions to further refine the values of resistance.

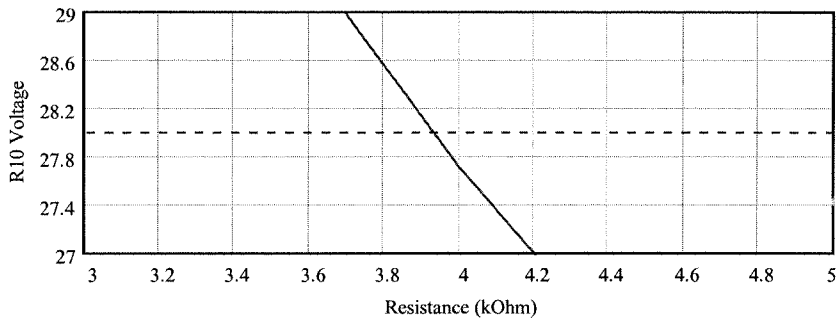
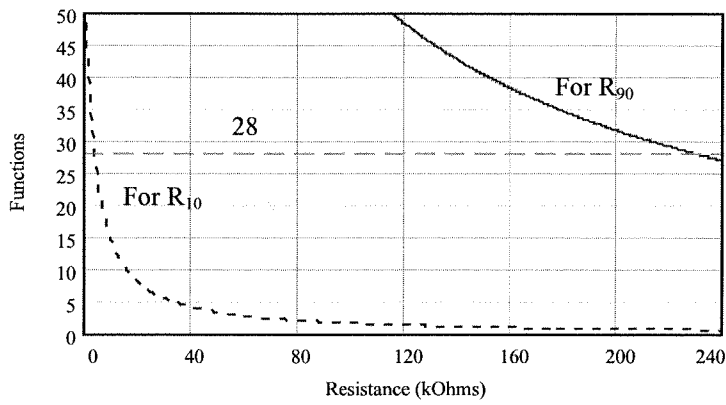

From this graph you can see that the value of resistance is $R_{10} \approx 3.95 \text{ k}\Omega$.

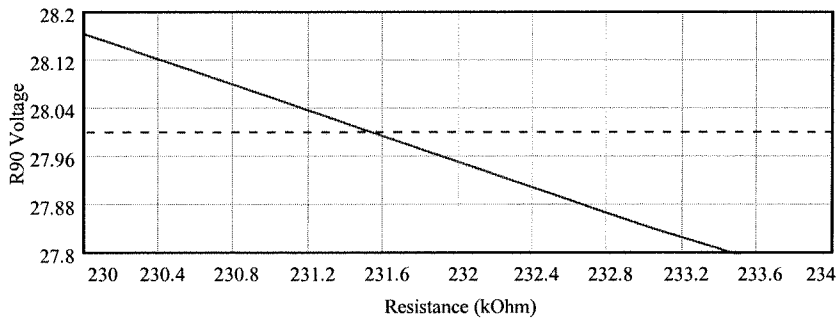

This graph shows that the value of $R_{90} \approx 231.5 \text{ k}\Omega$.

7.9

To make the stroke larger we use a short pivot arm from the solenoid to the pivot and a long pivot arm from the pivot to the working end. The stroke distance is then simply the ratio of arm lengths. The system would function as follows.

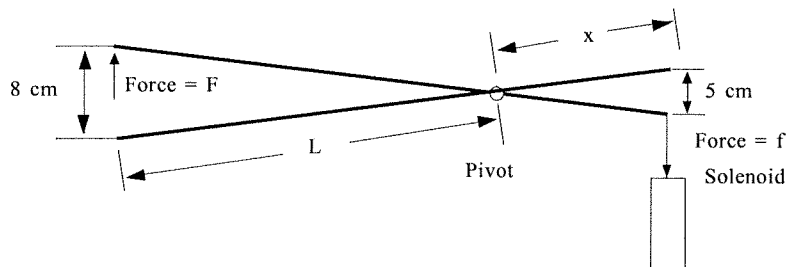

Let us pick $x = 10$ cm, then $L = (8/5)10$ cm = 16 cm. To find the force we equate torques about the pivot. Thus $8F = 5f$ provides that $F = (5/8)6$ N = 3.75 N.

7.10

We have,

$$(130 \text{ steps/rev})(10.5 \text{ rev/s}) = 1365 \text{ steps/s}$$

so we need 1365 pulses per second where each pulse produces one step.

7.11

The motor steps once for each pulse, so,

$$R = (2000 \text{ steps/s})(7.5^\circ/\text{step}) = 15000^\circ/\text{s}$$

There are 360° per revolution, so,

$$R = (15000^\circ/\text{s})/(360^\circ/\text{rev}) = 41.67 \text{ rev/s}$$

There are 60 seconds per minute, so,

$$R = (41.67 \text{ rev/s})(60 \text{ s/min})$$

$$R = 2500 \text{ rpm}$$

7.12

Since $F = pA$, then with $p = 90$ kPa and $A = 30$ cm²

$$F = (90 \times 10^3)(30 \times 10^{-4} \text{ m}^2)$$

$$F = 270 \text{ N}$$

7.13

For the hydraulic system the force is propagated by the pressure. So we have,

$$p_1 = p_2$$

or,

$$(F_1/A_1) = (F_2/A_2)$$

$$F_1 = F_2(A_1/A_2)$$

since $A = \pi D^2/4$ we can write this expression using the diameters as,

$$F_1 = F_2(D_1/D_2)^2$$

A 500 kg mass has a force under gravity of,

$$F_2 = mg = (500 \text{ kg})(9.8 \text{ m/s}^2) = 4900 \text{ N}$$

so the required lifting force is,

$$F_1 = (4900 \text{ N})(2/40)^2$$

$$F_1 = 12.25 \text{ N}$$

7.14

The pneumatic pressure required can be computed from the required force using,

$$F_1 = pA_1$$

or,

$$p = F_1/A_1 = 4F_1/[\pi(D_1)^2]$$

$$p = (4)(12.25 \text{ N})/[\pi(0.02 \text{ m})^2]$$

$$p = 39 \text{ kPa}$$

7.15

There are many possible ways to do this. Here is one using a comparator. This comparator is assumed to have a 5 volt high output so this is divided to obtain the required 4 volt SCR trigger. A simple divider provides the 7.5 volt comparator trigger voltage. As the light intensity increases the photocell resistance will drop, which increases V_1 . When the cell reaches 2.5 k Ω , V_1 will rise to 7.5 volts and the comparator will go high.

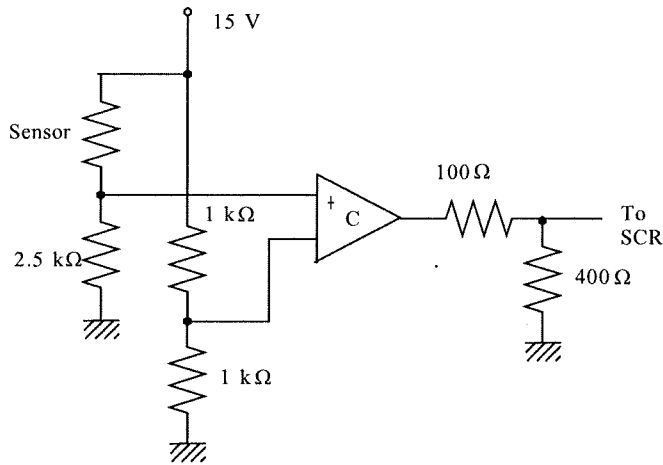

7.16

A block diagram of the required system can be constructed as follows,

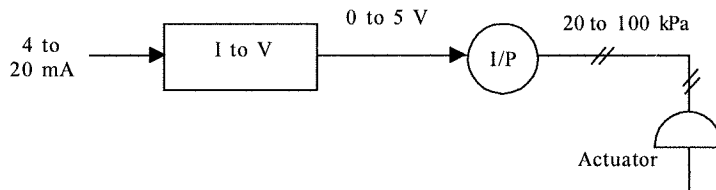

There are many ways to convert the 4 to 20 mA into 0 to 5 volts. One way is to use a 100 Ω resistor to convert the current to 0.4 to 2.0 volts. Then an amplifier with offset is needed.

$$V_1 = mV + V_0$$

or,

$$0 = 0.4m + V_0 \text{ so, } V_0 = -0.4m$$

$$5 = 2.0m + V_0$$

subtracting,

$$5 = 1.6m \text{ or } m = 3.125 \text{ thus } V_0 = -1.25$$

So the equation can be written:

$$V_1 = 3.125(V - 0.4)$$

This can be provided by a differential amplifier,

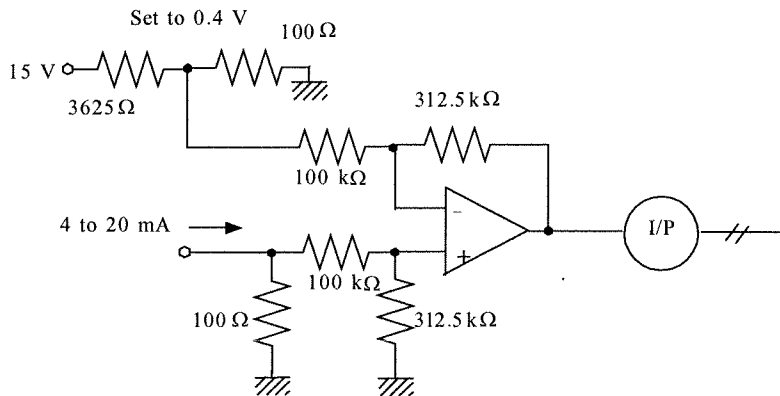

To get the area we see that 20 kPa must produce 200 N. Thus from the relation, $F = pA$ we have,

$$A = F/p$$

$$A = 200 \text{ N}/(20 \text{ kN/m}^2) = 0.01 \text{ m}^2$$

7.17

The relation between pneumatic pressure and force is,

$$F = pA$$

or

$$A = F/\rho$$

thus,

$$A = 30 \text{ lb}/(9 \text{ lb/in}^2)$$
$$A = 3.3 \text{ in}^2$$

7.18

For control valve sizing we use,

$$Q = C_v[\Delta p/S_G]^{1/2}$$

or,

$$C_v = Q[S_G/\Delta p]^{1/2} \quad C_v = 600[1.3/55]^{1/2}$$
$$C_v = 92.2$$

From Table 7.1 we would use a 3 inch or 8 cm pipe.

7.19

$$R = Q_{max}/Q_{min} = 32, \quad Q_{max} = 100 \text{ m}^3/\text{hr}, \text{ so}$$
$$Q_{min} = 100/32 = 3.125 \text{ m}^3/\text{hr}$$

The flow is given by,

$$Q = Q_{min}R^x$$

where $x = s/s_{max}$ is the fraction of stem travel, so,

$$Q = 3.125(32)^{2/3} = 31.5 \text{ m}^3/\text{hr}$$

and

$$Q = 3.125(32)^{4/5} = 50 \text{ m}^3/\text{hr}$$

7.20

We will use the relation,

$$Q = C_v[\Delta p/S_G]^{1/2} \text{ or, } C_v = Q[S_G/\Delta p]^{1/2}$$

We need the flow in gal/min where $1 \text{ gal} = 0.00379 \text{ m}^3$

$$Q = (65 \text{ m}^3/\text{hr})(1 \text{ hr}/60 \text{ min})(1 \text{ gal}/0.00379 \text{ m}^3)$$

$$Q = 285.8 \text{ gal/min}$$

The pressure is simply the gauge pressure at the outlet,

$$\Delta p = \rho gh = (10^3 \text{ kg/m}^3)(9.8 \text{ m/s}^2)(20 \text{ m})$$

$$\Delta p = 196 \text{ kPa} \quad (1 \text{ Pa} = 1.45 \times 10^{-4} \text{ psi})$$

$$\Delta p = 28.42 \text{ psi}$$

now we can find C_v ,

$$C_v = (285.8)[1/28.42]^{1/2}$$

$$C_v = 53.5$$

From Table 7.1 this requires a 2 inch or 5 cm valve.

7.21

$$R = Q_{max}/Q_{min} = 30$$

When $Q = 65 \text{ m}^3/\text{hr}$ the stem is half open, $s = 2.5 \text{ cm}$, so, $Q = 65 = Q_{min}(30)^{0.5}$

or

$$Q_{min} = 11.87 \text{ m}^3/\text{hr}$$

The maximum flow is found as, $Q_{max} = RQ_{min} = (30)(11.87)$

$$Q_{max} = 356 \text{ m}^3/\text{hr}$$

For $100 \text{ m}^3/\text{hr}$,

$$100 = (11.87)(30)^{s/5}$$

$$(30)^{s/5} = 8.42$$

$$(s/5)\log(30) = \log(8.42)$$

$$s = 3.13 \text{ cm}$$

7.22 A diagram of this problem is as follows,

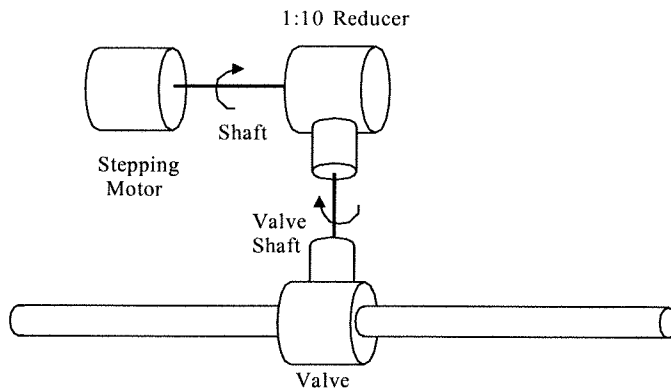

Five turns of the valve shaft require 50 turns of the stepping motor shaft. This means a total of
 $50 \text{ turns} \times 360^\circ/\text{turn} = 18,000^\circ$
 If there are 3.6° per step to the motor then this will take,
 $18000^\circ/3.6^\circ/\text{step} = 5000 \text{ steps}$
 If the maximum stepping rate is 250 steps/s then the time to complete 5000 steps is,
 $t = 5000 \text{ steps}/250 \text{ steps/s} = 20 \text{ seconds}$

7.23

(a) For a linear control valve 40 gal/min represents
 $(40/90) = 0.444$ of the range or 44.4% of range.

In terms of signal we must have,

$$p = 0.444(15 - 3) + 3$$

$$p = 8.33 \text{ psi}$$

(b) For an equal percentage valve with $R = 6$ and $Q_{min} = 15 \text{ gal/min}$ we use the expression,

$$Q = Q_{min}R^x, \text{ where } x = s/s_{max} \text{ thus,}$$

$$40 = (15)(6)^x \text{ gives}$$

$$x = 0.547 \text{ or } 54.7\%$$

This is a signal pressure of,

$$p = 0.547(15 - 3) + 3$$

$$p = 9.56 \text{ psi}$$

Supplementary Problems

S7.1

(a) The stepper moves 2.5° per step so to get a speed of $R \text{ rpm}$ we need a stepping rate or frequency of

$$f = R (\text{rev/min})(360^\circ/\text{rev})/(2.5^\circ/\text{step}) = 144R \text{ steps/min} = 2.4R \text{ steps/sec} = 2.4R \text{ Hz}$$

So the 100 to 200 rpm is provided by an input frequency from 240 to 480 Hz. We must convert the 4-20 mA to a voltage and let this be input to a V/F converter to produce the required frequency variation. Suppose we choose to convert the current to a voltage range of 1.0 to 2.0 volts. Then the V/F converter must be characterized by: $f = KV_{in}$ so that $240 = K(1 \text{ V})$ and therefore $K = 240$. You can see then that when $V_{in} = 2 \text{ volts}$ we get $f = 480 \text{ Hz}$ as required.

From the Figure 3.26, showing V/F conversion using the LM 331, we find,

$$K = \frac{R_s}{R_L} \frac{1}{2.09} \frac{1}{R_t C_t} = 240 \text{ Let's use } R_s = 10 \text{ k}\Omega \text{ and } R_L = 10 \text{ k}\Omega \text{ then we get,}$$

$$240 = \frac{10}{10} \frac{1}{2.09} \frac{1}{R_t C_t} \text{ or } R_t C_t = 2 \times 10^{-3}$$

So if we pick $C_t = 0.1 \mu\text{F}$ then $R_t = 20 \text{ k}\Omega$.

To convert the current to voltage we have $V_{in} = mI + V_0$ so we get

$$1 = 0.004m + V_0$$

$$2 = 0.020m + V_0$$

solving we find $m = 62.5$ and $V_0 = 0.75 \text{ V}$. The following circuit provides this response.

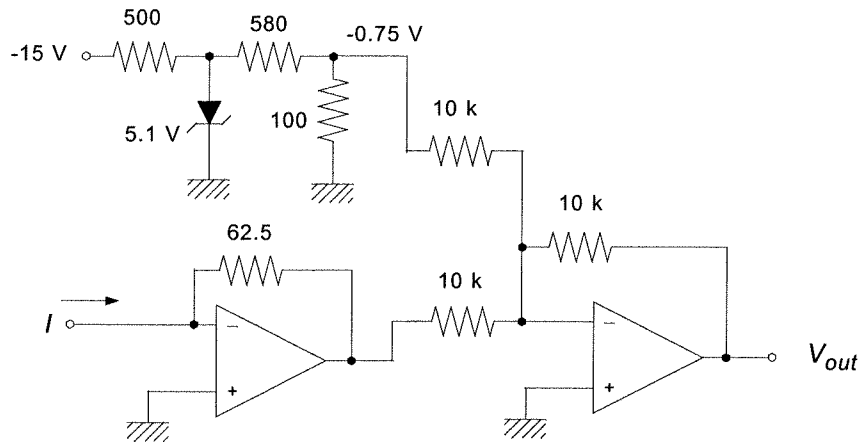

S7.2

(a) For a total travel of 4 cm and with 0.18 cm/turn we find, $N = 4/0.18 = 22.2$ turns of the gear.

(b) If the rotational rate is 15 rpm then the total time required will be,

$$t = 22.2 \text{ turns}/(15 \text{ turns/min}) = 1.48 \text{ minutes}$$

Since the rangeability is given as $R = (Q_{max}/Q_{min}) = 20$ and the maximum flow as $Q_{max} = 0.6 \text{ m}^3/\text{min}$, we find,

$$Q_{min} = Q_{max}/R = (0.6 \text{ m}^3/\text{min})/20 = 0.03 \text{ m}^3/\text{min}$$

(c) 90% of the maximum is, $Q = 0.9(0.6 \text{ m}^3/\text{min}) = 0.54 \text{ m}^3/\text{min}$. Thus we form the equation,

$$Q = 0.54 \text{ m}^3/\text{min} = (0.03 \text{ m}^3/\text{min})20^x$$

where $x = s/s_{max}$ is the fraction of stem travel.

Thus,

$$20x = 18$$

$$x = \log(18)/\log(20) = 0.965$$

and since $s_{max} = 4 \text{ cm}$, we find $s = 3.86 \text{ cm}$.

S7.3

Well, first let's just convert the current to voltage by passing it to ground through a 100 Ω resistor. Then the controller signal will be a voltage of 0.4 to 2.0 volts. This means that if the controller sends out 20 mA which becomes 2.0 volts then a comparator output should go high to the up terminal of the motor. Now suppose the controller input is 10 mA or 1.0 volts. Well, another comparator output should go high to the down terminal until the stem position is reached. We thus put the 1 kΩ motor resistor in a bridge so that its endpoint voltages are 0.4 and 2.0 volts. The following figure shows the resulting circuit.

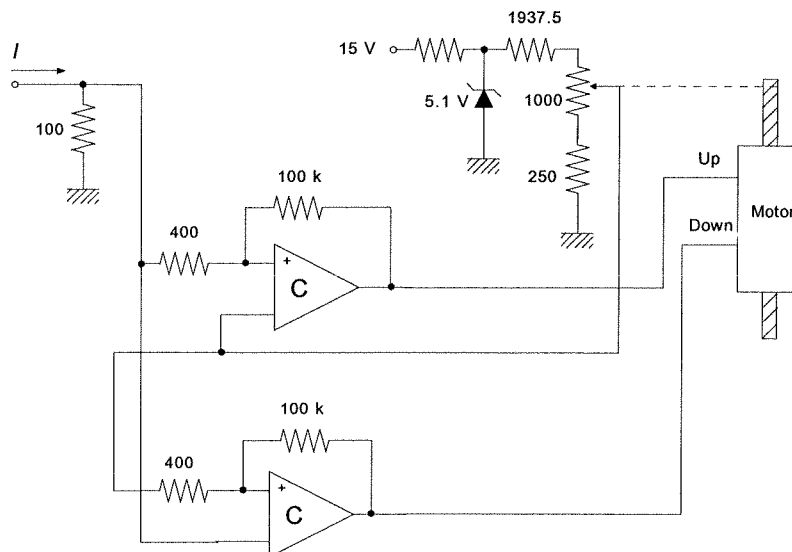

Notice that some hysteresis was provided for each comparator to prevent chattering as the correct stem position is reached. Assuming a 5.0 volt TTL output the hysteresis is $400 \times 5 / 100 \text{ k} = 0.02$ volts which is about 1.25% of the range.

CHAPTER 8

8.1

The operation of a microwave oven in terms of a discrete state system is described in two phases. Phase 1 is to identify the operational elements of the system (inputs and outputs) and Phase 2 is to define the sequence of events necessary to employ the oven.

- Phase 1:
1. generator (source of microwaves)
 2. fan (for cooling)
 3. light inside oven
 4. safety switch on door
 5. main power switch
 6. timer switch

(This is a basic set, others could be added)

- Phase 2:
1. open door and put in food
 2. close door
 3. set timer
 4. turn main power on
 - (5. open and close door to take a look)
 6. time up (cooking finished)

Now these two phases are combining by specification of what the state of the elements identified in Phase 1 should be during Phase 2. The following table gives a typical solution.

CONDITION	GENERATOR	FAN	LIGHT	DOOR SW	PWR SW	TIMER
1. Open door	OFF	OFF	ON	ON	OFF	OFF
2. Place food	OFF	OFF	ON	ON	OFF	OFF
3. Close door	OFF	OFF	OFF	OFF	OFF	OFF
4. Set timer	OFF	OFF	OFF	OFF	OFF	OFF
5. Power on	ON	ON	OFF	OFF	ON	ON
6. Open door	OFF	OFF	ON	ON	ON	OFF
7. Close door	ON	ON	OFF	OFF	ON	ON
8. Time up	OFF	OFF	OFF	OFF	OFF	OFF
9. Stop Button	OFF	OFF	OFF	OFF	OFF	OFF

8.2

We present just a basic system here. With some thought many features can be added or enhanced. We need to identify the variables in the system and then the sequence of events necessary to make it work.

- Inputs:
1. coin inserted
 2. sugar button
 3. cream button
 4. start button

- Outputs:
1. cup drop solenoid
 2. coffee valve
 3. sugar inject solenoid
 4. cream inject solenoid

Sequence of events: (we assume the sugar and cream buttons are push-on, push-off so the user can change their mind)

1. insert coin
2. push buttons for sugar and/or cream.
If both are pushed-off the coffee will be black
3. push start button to brew coffee

8.3

The flow chart is easily constructed by simply using the narrative description given in the solution of Example 8.3.

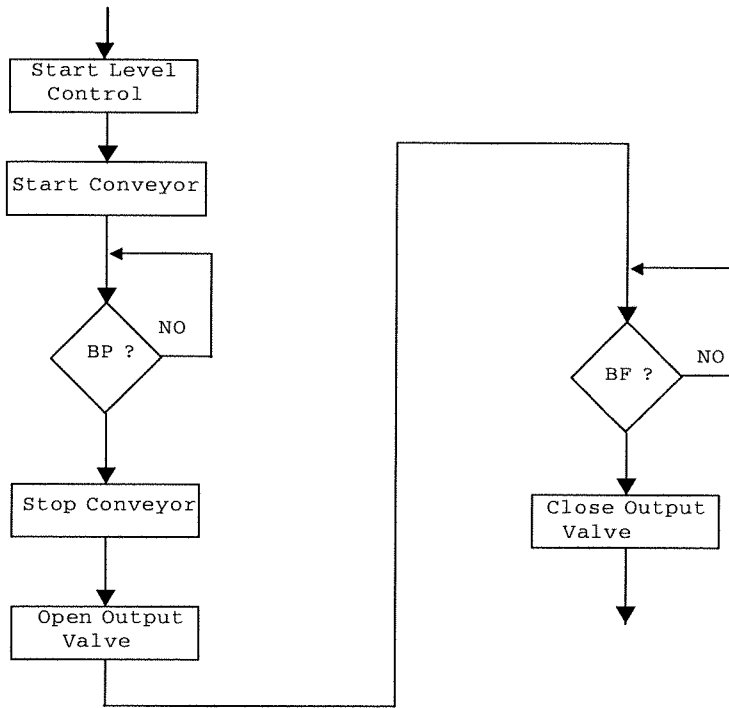

8.4

We construct this flowchart using the simple narrative statement of the sequence of events given above.

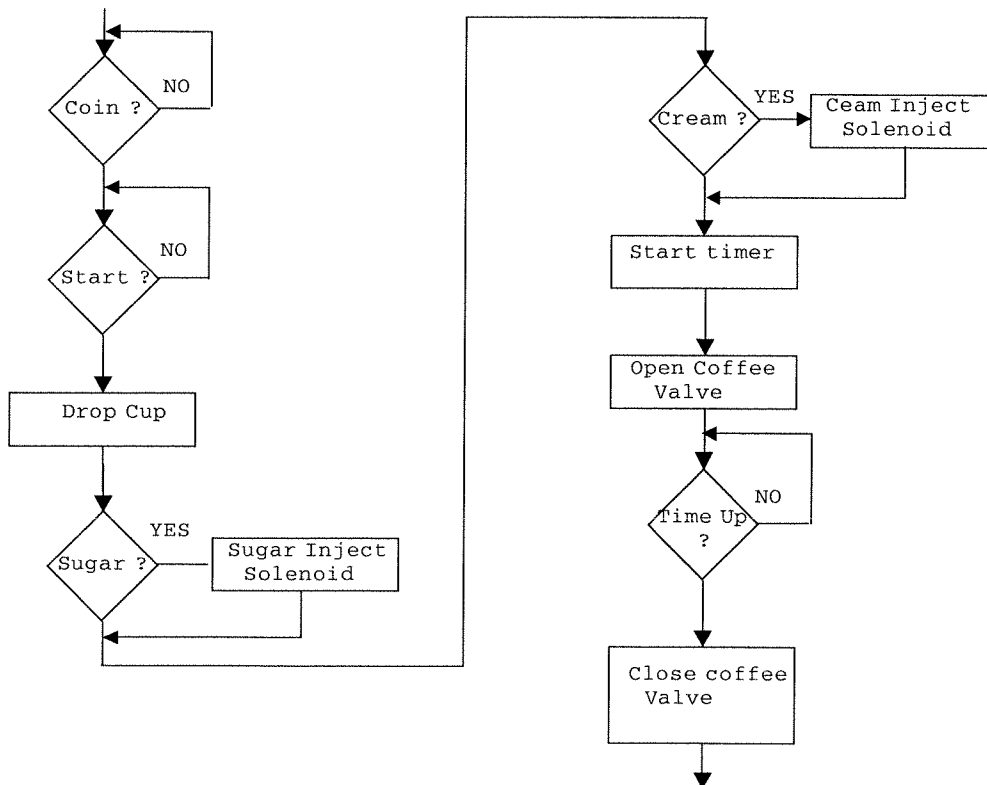

8.5

First the system state must be defined in terms of the variables of the system. An added variable, R, is true when the system is running. We let the state be defined by:

(BP)(BF)(R)(LC)(V)(M)

The first three, (BP)(BF)(R), are inputs while the last three, (LC)(C)(M), are outputs. The entire state of six variables determines what assignments to make for the outputs.

For the running phase of the system we simply define the values of each of the variables in the state defined above.

PRE-STATE		POST-STATE	COMMENT
1. 000000	»	000000	Idle state, not running
2. 001000	»	001101	Conveyor turned on, level control on
3. 001101	»	001101	Waiting for a bottle
4. 101101	»	101110	Bottle present, stop conveyor, start fill
5. 101110	»	101110	Waiting for bottle fill
6. 111110	»	111101	Bottle full, stop fill, start conveyor
7. 111101	»	001101	Bottle not present, bottle not full go to 3

8.6

We must identify the conditions under which each of the seven outputs should be true, i.e., active.

Let's start with valve, VA. This should be open (true) if LA is false but we cannot simply set $VA = \overline{LA}$ because during the empty phase we do not want VA to open when the level falls below LA. Thus we combine this with VC.

$$VA = \overline{LA} \bullet \overline{VC}$$

For valve, VB, we want it open (true) when LB is not true. But in addition we want it to not open during the empty phase (VC) and while the A fill is occurring, so

$$VB = \overline{LB} \bullet \overline{VC} \bullet LA$$

When LA and LB are both true we can start the timer,

$$TM = LA \bullet LB$$

Now we let TU determine the state of the heat and stir,

$$H = \overline{TU}$$

$$S = \overline{TU}$$

where we assume that TM is edge triggered, i.e., when TM goes high the timer starts. This drives TU low until the timer completes when TU goes high.

Valve, VC, is to open (true) when the timer completes (TU goes high) and remain so until LE goes true for tank empty. There is a problem here however. If we simply set $VC = TU \bullet LE$ then the valve will open as soon as VA becomes true and fills the system above LE. One way to solve this is to add a flip-flop which is set by TU and reset (cleared) by LE. In this way VC can only be true during empty and not during fill. The hardware configuration and timing are given by the following diagram.

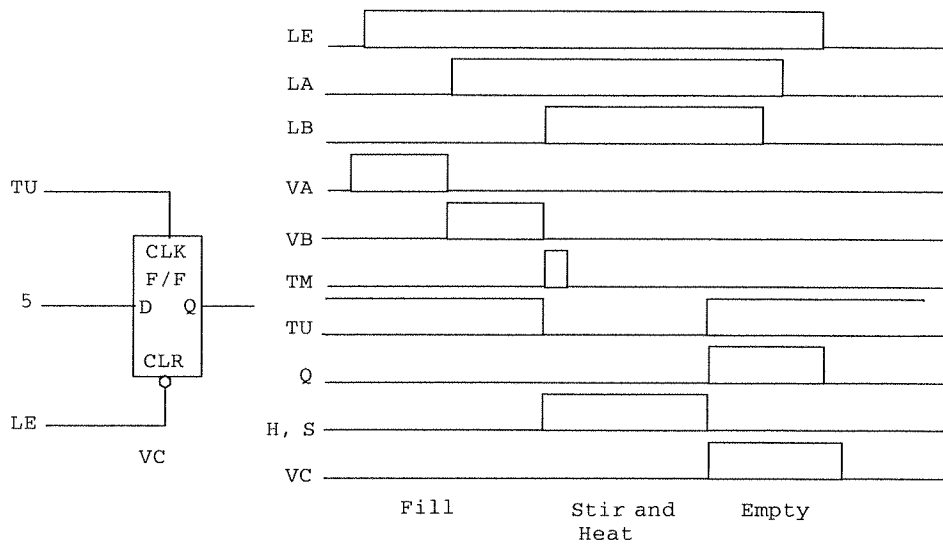

With this system the equation for VC will be, $VC = LE \cdot Q$

8.7

The following physical ladder diagram will provide the required sequence.

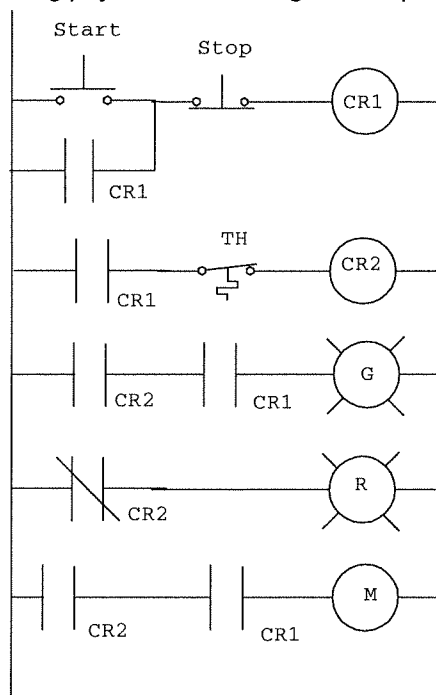

8.8

The following ladder diagram will provided the indicated sequencing.

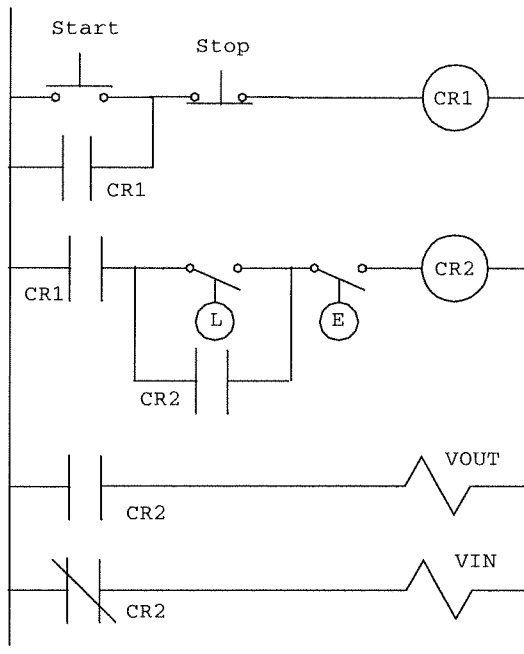

8.9

The following ladder diagram provides the required running phase.

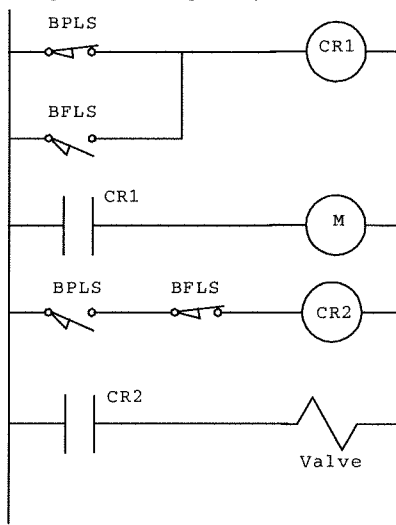

8.10

Note that the timer, TR1, is assumed to be such that when its rung is true the timer goes true for the indicated time, 5 minutes, thus it is an ON timer.

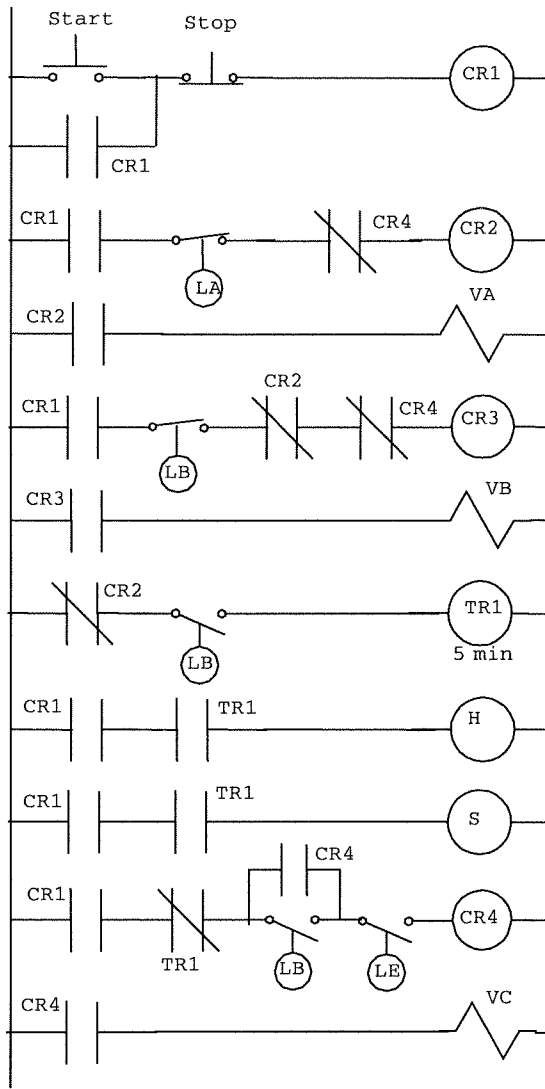

8.11
The text does not specify the green running light.

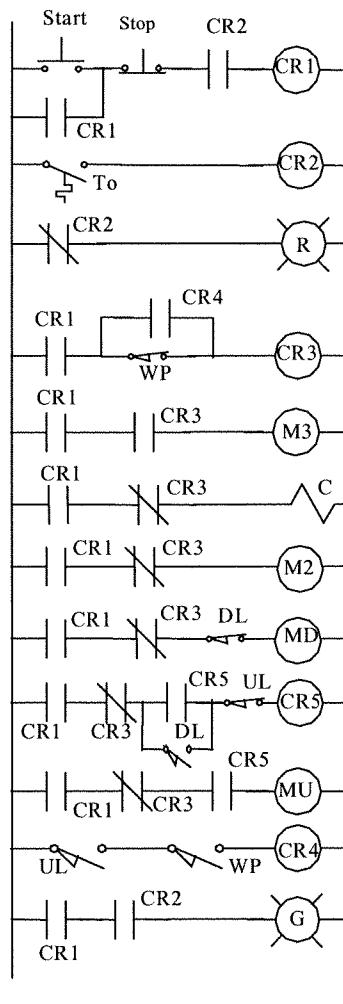

8.12

For this solution it is assumed that both NO and NC connections are available. An interesting modification is to specify that only NO (or NC) are available. The following assignments are made for inputs and outputs:

INPUTS:

- START (NO) = 00
- STOP (NC) = 01
- LA (NC) = 02
- LA (NO) = 03
- LB (NC) = 04
- LB (NO) = 05
- LE (NO) = 06

OUTPUTS:

- VA = 08
- VB = 09
- VC = 10
- S = 11
- H = 12

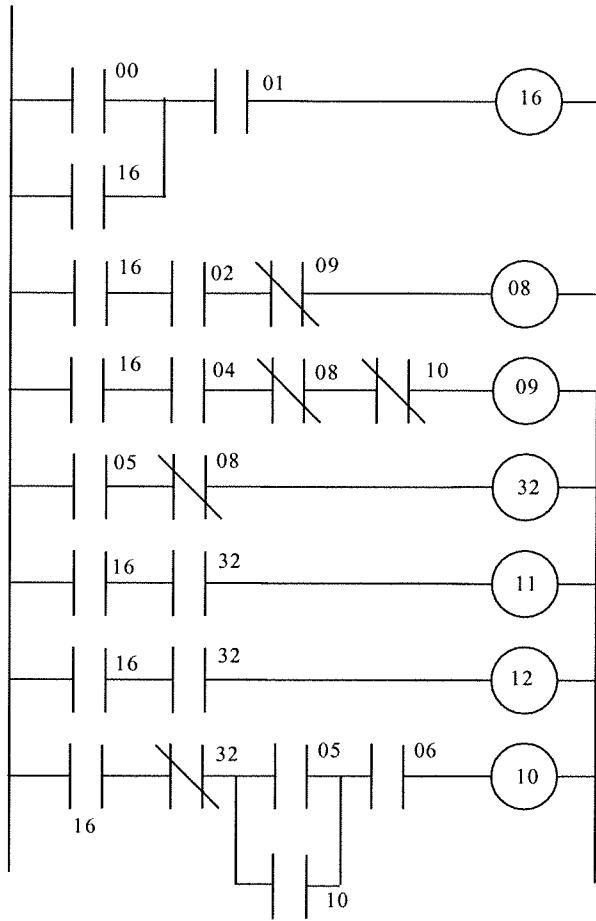

8.13

The following programmed ladder diagram solves this requirement.

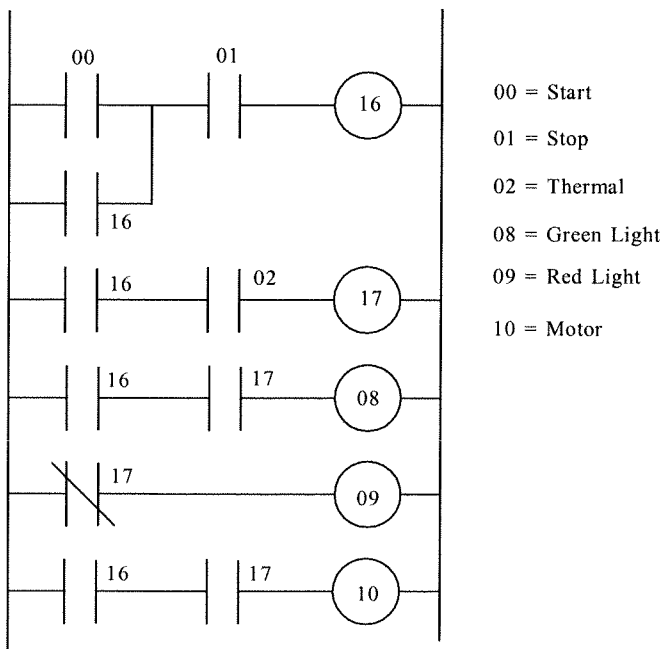

8.14

Assumption: level switches close on a rising level

INPUTS: ON PB (NO) = 00 OFF PB (NO) = 01
 E LSW (NO) = 02 L LSW (NO) = 03
 OUTPUTS: VIN = 08 VOUT = 09

Counter: (1.5 min)/(60 s/min)/(10 ms/tick) = 9000 ticks

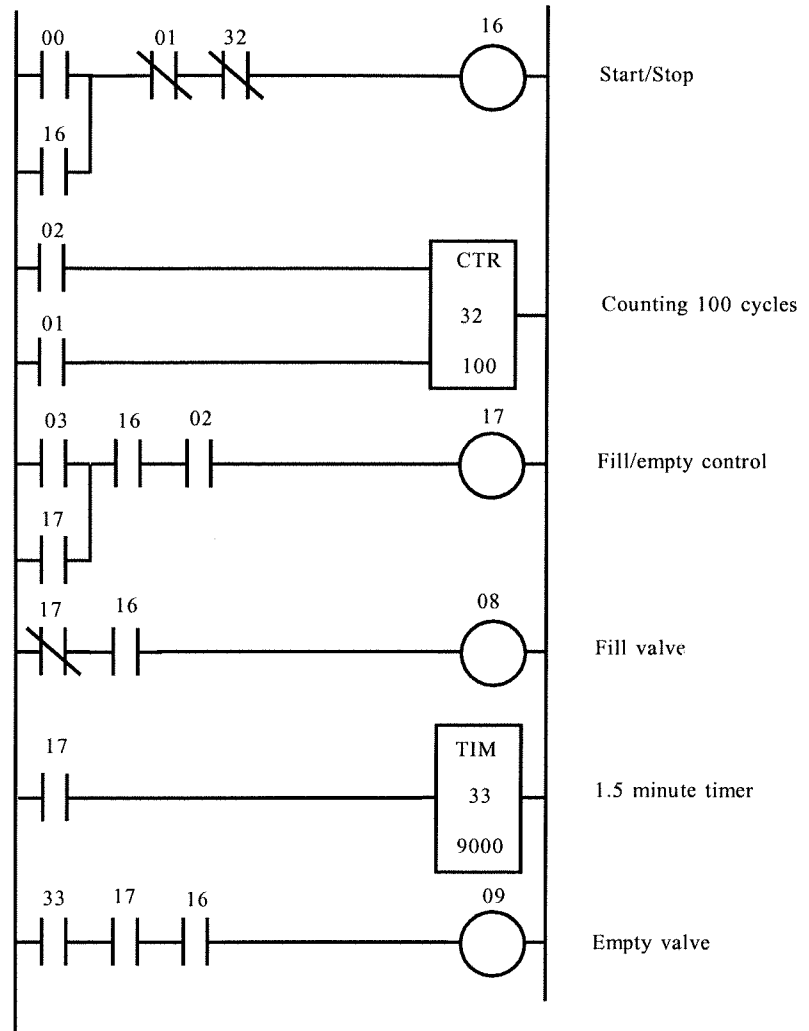

8.15

The programmed ladder diagram uses only the NC switches specified in the actual hardware.

Assignments are:

INPUTS: START = 00 STOP = 01 LLS = 02 RLS = 03
 OUTPUTS: CW = 08 CCW = 09

Timer: (assume 10 ms/tick) (30 s)/(10 ms/tick) = 3000 ticks

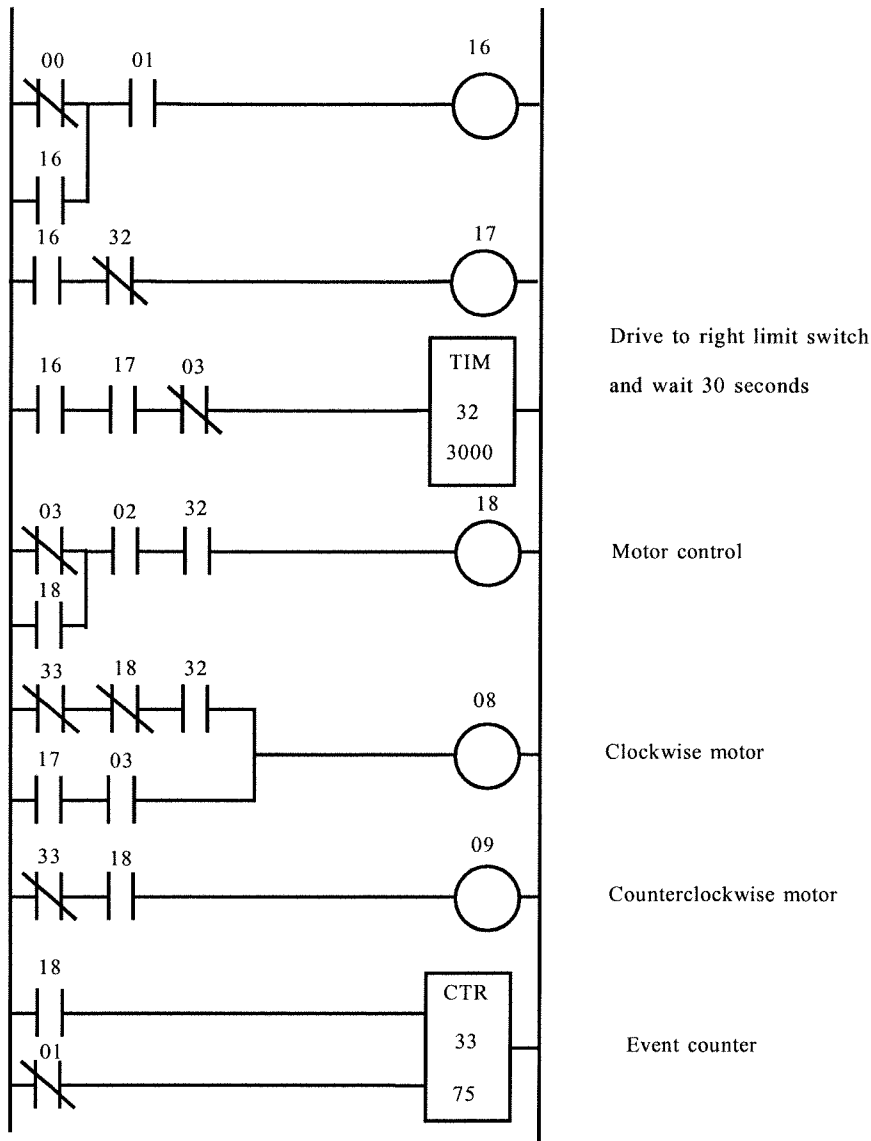

8.16

This solution makes the assumptions that WP is NO and closes when a work is present, DL is NO and closes when the limit is reached, and UL is NO and closes when the limit is reached. The following assignments are made:

INPUTS:	START (NO) = 00	OUTPUTS:	RED LIGHT = 08
	STOP (NC) = 01		M3 CONVEYOR = 09
	THERMAL (NO) = 02		WORK CLAMP = 10
	WP (NO) = 03		M2 DRILL = 11
	DL (NO) = 04		MD DOWN = 12
	UL (NO) = 05		MU UP = 13
			GREEN LIGHT = 14

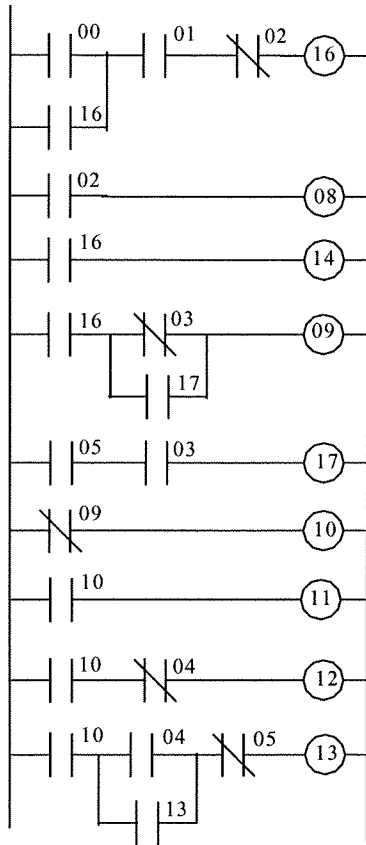

Supplementary Problems

S8.1

We specify that the liquid fill and solid fill occur at the same time. The first part of the flow chart reflects this requirement. After this the flow chart just follows the specified actions.

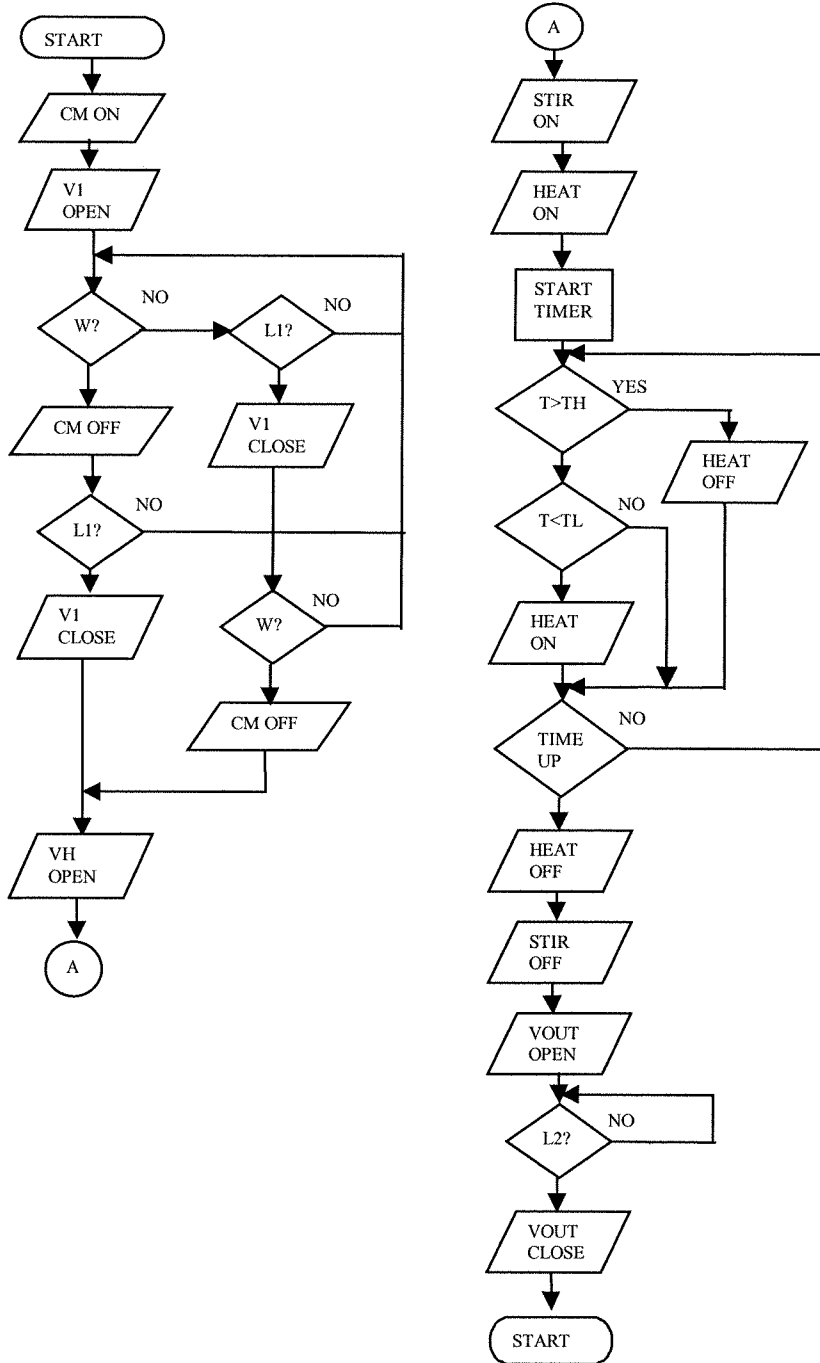

S8.2

We specify a Start and Stop push button system as usual. The problem specifies that only NO connections are available for all sensors. Yet in the following ladder diagram we show both NO and NC switches. If the system were really going to be implemented by relay logic then all NC rungs

would have to be split into two rungs to provide a NC position. For example Rung 2 to operate the conveyor for dry material movement uses a NC weight (W) switch. If we were constrained to use only the NO position this would be written as two loops:

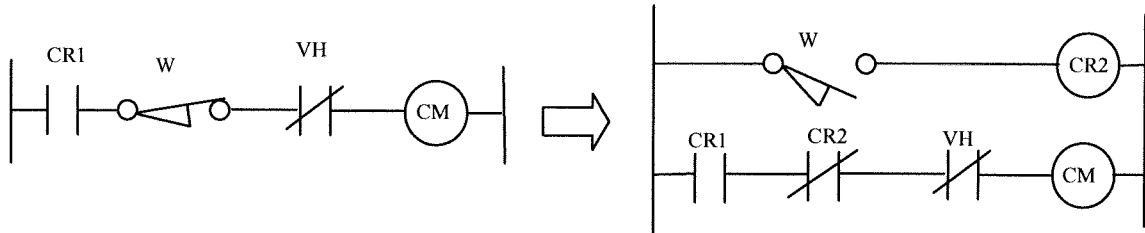

So, here is the ladder diagram using both NO and NC connections

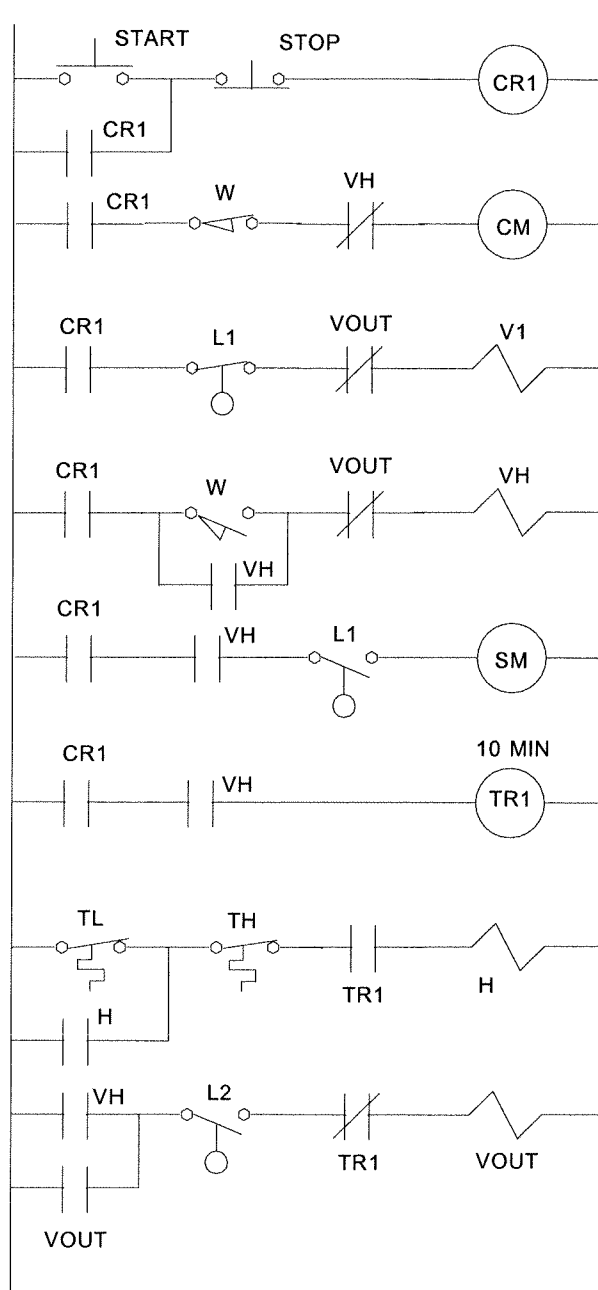

S8.3

Using the port definitions shown the programmed ladder diagram which implements the physical diagram of Problem S8.2 is given below.

W = 00	CM = 08	Timer = 32
L1 = 01	V1 = 09	
L2 = 02	VH = 10	
TL = 03	SM = 11	
TH = 04	VOUT = 13	

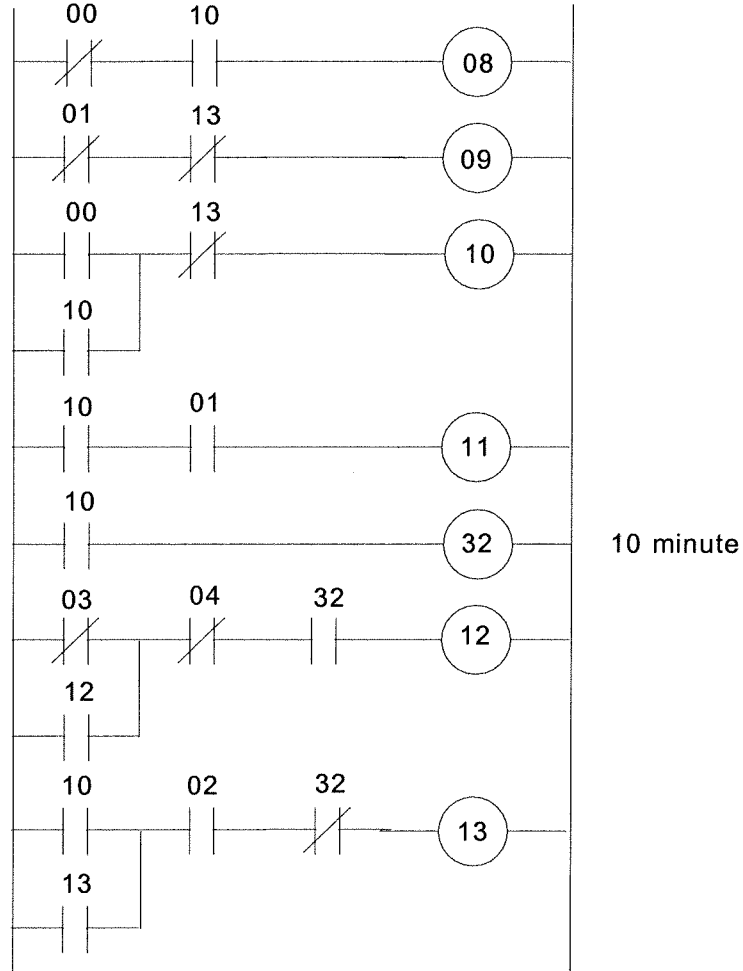

CHAPTER 9

9.1

The process load consists of the following variables:

Input flow A: Q_A Output flow B: Q_B
 Input temperature: T_o Ambient temperature: T_A

9.2

- a) Self: yes, will adopt some temperature
 Load: outside temperature, doors/windows open, humidity, cooking, number of people.
 Transient: taking shower/bath, cooking, opening of door or window.
 Lag: yes, start compressor, cool evaporator coils, move volume of air through house.
- b) Self: no, if conveyor stops, crackers burn-up.
 Load: oven temperature, size of crackers, ingredients of crackers, number of crackers, feed rate of crackers.
 Transient: change of oven temperature, ingredient of crackers.
 Lag: no substantial process lag is involved, except crackers in oven when change is made may be in-between settings.
- c) Self: no, tank will overflow or empty.
 Load: input pressure head, output flow rate, viscosity of liquid, temperature.
 Transient: change in head pressure, change in output flow rate, change in temperature.
 Lag: virtually no process lag.

9.3

$$e_p = 100 * (C_{sp} - C_m) / (C_{max} - C_{min})$$

$$e_p = 100(327 - 294) / (460 - 2240) = 13.75\%$$

9.4

First we need an equation relating voltage and motor speed.

$$S = mV + S_o$$

we have, $800 = 25m + S_o$

$$1750 = 50m + S_o$$

subtracting, $950 = 25m$ thus $m = 38 \text{ rpm/V}$

then, $800 = (25)(38) + S_o$ gives $S_o = -150 \text{ rpm}$

so, $S = 38V - 150$

(a) When $V = 38$ volts this equation gives a speed of,

$$S = (38)(38) - 150$$

$$S = 1294 \text{ rpm}$$

(b) In terms of percent of range this represents a controller output of,

$$V_p = 100(1294 - 800) / (1750 - 800)$$

$$V_p = 52\%$$

9.5

A diagram of this system helps to see how it works,

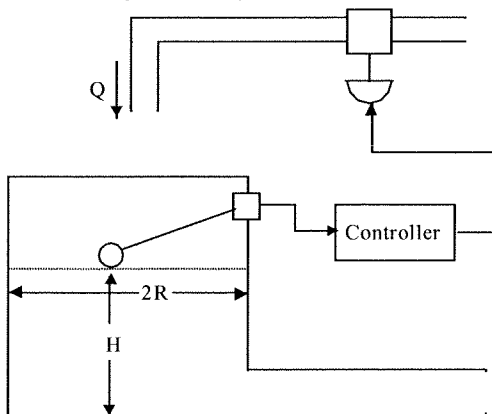

(a) With a neutral zone of 1 m and no over/under-shoot the fill valve will switch open at 11.5 m and close at 12.5 m. Suppose the volume flow rate is called Q (m^3/min), then the time to fill a volume V (m^3) is given by,

$$t = V/Q \text{ (in minutes)}$$

Suppose the level is at 11.5 m and the fill valve opens. Then the input flow is $2 \text{ m}^3/\text{min}$ and the (constant) outflow is $1 \text{ m}^3/\text{min}$. Therefore $Q = 1 \text{ m}^3/\text{min}$. The valve will stay open until the level reaches a level of 12.5 m. This represents a volume of,

$$V = \pi R^2 H$$

where $R = 2.5 \text{ m}$ and $H = 1 \text{ m}$. The time to fill this volume is,

$$t = \pi(2.5 \text{ m})^2(1 \text{ m})/1 \text{ m}^3/\text{min}$$

$$t = 19.6 \text{ min}$$

At 12.5 m the fill valve closes and the flow becomes $Q = -1 \text{ m}^3/\text{min}$. The time to drop to 11.5 m will be exactly the same so that the total cycle period is,

$$T = 2t = 2(19.6 \text{ min})$$

$$T = 39.2 \text{ min}$$

(b) The graph of level change versus time is given by,

$$\delta H = Qt/\pi R^2 \text{ where } Q = \pm 1 \text{ m}^3/\text{min}$$

or, $\delta H = \pm 0.051 t$ in meters and where the switch between + and - occurs every 19.6 minutes. The graph of this response follows

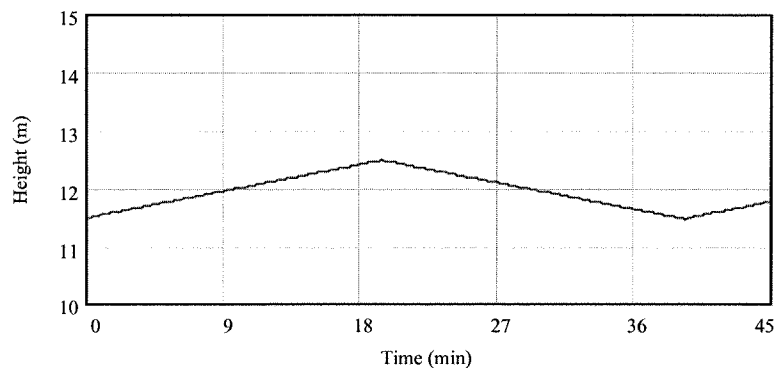

9.6

With a $\pm 2\%$ neutral zone the equations for temperature drop and temperature rise, Eqs. (9-7) and (9-8), are the same but the trip points become,

$$T_{low} = 323 - 0.02(323) = 316.54 \text{ K}$$

$$T_{high} = 323 + 0.02(323) = 329.46 \text{ K}$$

the lag remains 0.5 min. It is quite possible to calculate the cycling period since the behavior is totally described. Suppose the temperature is at 323 K and the system is heating. The time to reach the upper trip point is,

$$t_1 = (329.46 - 323)/(4 \text{ K/min}) = 1.615 \text{ min}$$

Heating continues for $t_2 = 0.5 \text{ min}$ which results in a temperature rise of

$$\Delta T = (0.5 \text{ min})(4 \text{ K/min}) = 2 \text{ K (the overshoot) so that the temperature is } 331.46 \text{ K.}$$

Cooling at -2 K/min occurs until the lower trip point is reached, which takes a time of,

$$t_3 = (316.54 - 331.46)/(-2) = 7.46 \text{ min}$$

Cooling continues for $t_4 = 0.5 \text{ min}$, which results in a temperature drop of

$$\Delta T = (0.5 \text{ min})(-2 \text{ K/min}) = -1 \text{ K (the undershoot)}$$

so that the temperature drops to 315.54 K.

Finally we heat again until the temperature reaches 323 K to complete one cycle. This takes a time,

$$t_5 = (323 - 315.54)/4 = 1.865 \text{ min}$$

The total time, which is the cycle time, is the sum of these five times, $t_{TOT} = 11.94 \text{ min}$. The following graph shows this same process

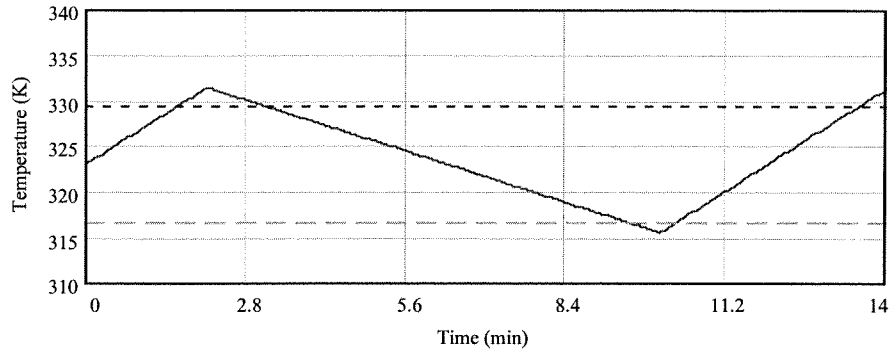

9.7 A setpoint of 60 gal/min with a ± 5 gal/min deadband means that the trip points are,

$$Q_{upper} = 65 \text{ gal/min}$$

$$Q_{lower} = 55 \text{ gal/min}$$

The controller output is determined by the relations,

$$p(t) = p(0) + 6t \quad \text{for } Q > Q_{upper}$$

$$p(t) = p(0) - 6t \quad \text{for } Q < Q_{lower}$$

Examination of Figure 9.25 and use of the above output relations shows the following events:

For $t < 1$ min, $Q < 65$ gal/min, so $p(t) = 50\% = \text{constant}$

(1) at $t = 1$ min, Q reaches 65

$$p(t) = 50 + 6(t - 1)$$

(2) at $t = 4.25$ min, $Q < 65$ again, so

$$p(t) = 50 + 6(4.25 - 1) = 69.5\% \text{ (constant)}$$

(3) at $t = 4.75$ min, $Q < 55$,

$$p(t) = 69.5 - 6(t - 4.75)$$

(4) at $t = 8$ min, $Q > 55$

$$p(t) = 69.5 - 6(8 - 4.75) = 50\% \text{ (constant)}$$

This is plotted in the following graph of output versus time.

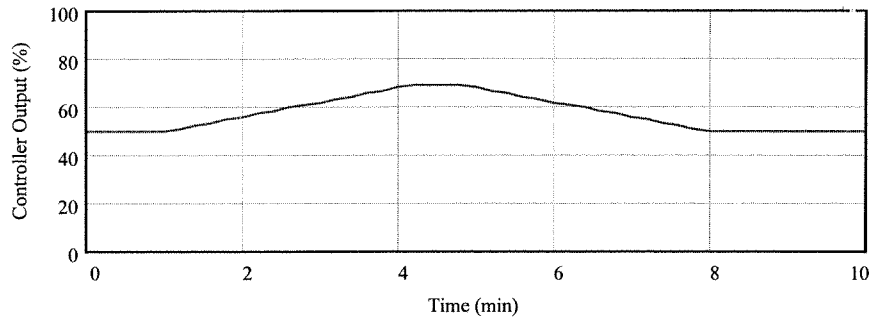

9.8

For the proportional controller the equation for output is,

$$p = K_p e_p + p_0$$

Here,

$$p_0 = 50\% \quad \text{and} \quad e_p = 100(73.5 - T)/(130 - 50)$$

$$e_p = 1.25(73.5 - T)$$

Ideally to make the error zero ($T = 73.5^\circ\text{C}$) the output should be 50%. A load change may modify conditions so that an output other than 50% is required for zero error. The system will adopt some permanent offset error to provide the necessary correction to p_0 . The error depends upon the magnitude of the gain, K_p .

Suppose the new output must be 55%, then the offset error will be,

$$e_p = (55 - 50)/K_p = 5/K_p$$

and temperature can be found from,

$$T = 73.5^\circ\text{C} - 0.8e_p$$

$$(a) K_p = 0.1 \quad e_p = 50\% \quad T = 33.5^\circ\text{C}$$

$$(b) K_p = 0.7 \quad e_p = 7.14\% \quad T = 67.8$$

(c) $K_p = 2.0$	$e_p = 2.5\%$	$T = 71.5$
(d) $K_p = 5.0$	$e_p = 1\%$	$T = 72.7$

9.9

For this problem we use the controller output equation of Problem 9.8 with $K_p = 2$

$$p = 2e_p + 50$$

where $e_p = 1.25(73.5 - T)$

(a) $T = 61^\circ\text{C}$,

$$e_p = 1.25(73.5 - 61) = 15.625\%$$

$$p = 2(15.625) + 50 = 81.25\%$$

(b) $T = 122^\circ\text{C}$,

$$e_p = 1.25(73.5 - 122) = -60.625\%$$

$$p = 2(-60.625) + 50 = -71.25\% \text{ K } 0\% \text{ (saturated)}$$

(c) $T = (82 + 5t)^\circ\text{C}$ (T increasing linearly in time)

$$e_p = 1.25[73.5 - (82 + 5t)] = -10.625 - 6.25t$$

$$p = 2(-10.625 - 6.25t) + 50$$

$$p = 28.75 - 12.5t \%$$

9.10

A reset action of 2.2 minutes means that $T_I = (2.2)(60) = 132$ seconds. Therefore the integral gain is,

$$K_I = 1/T_I = 1/132 = 0.0076 \text{ } \%/(\% \cdot \text{s}) \text{ (or } \text{s}^{-1}\text{)}$$

The output equation is,

$$p(t) = K_I \int e_p dt + p(0)$$

where $p(0) = 0$ and $e_p = 2.2\%$ (fixed)

$$p(t) = 0.0076 \int 2.2 dt = 0.017 \int dt$$

$$p(t) = 0.017t \% \text{ (increasing linearly with time)}$$

9.11

The derivative controller output is given by,

$$p(t) = K_D \frac{de_p}{dt}$$

thus,

$$p(t) = 4 \frac{d}{dt} [2.2 \sin(0.04t)] = (4)(2.2)(0.04) \cos(0.04t)$$

$$p(t) = 0.352 \cos(0.04t)$$

9.12

The error given in Figure 9.26 is used in this and the next few problems. The error can be described in time by the following section-by-section equations:

(1) $0 < t < 2$ $e_p = t$ (ramp at 1 %/s)

(2) $2 < t < 4$ $e_p = -2.5t + 7$ (ramp at -2.5 %/s)

(3) $4 < t < 6$ $e_p = 1.5t - 9$ (ramp at 1.5 %/s)

For the proportional controller with $K_p = 2$ and $p_0 = 50\%$ the equations for each section of the error relation is given by,

(1) $p = 2t + 50$

(2) $p = 2(-2.5t + 7) + 50 = -5t + 64$

(3) $p = 2(1.5t - 9) + 50 = 3t + 32$

These relations for the output are plotted as follows.

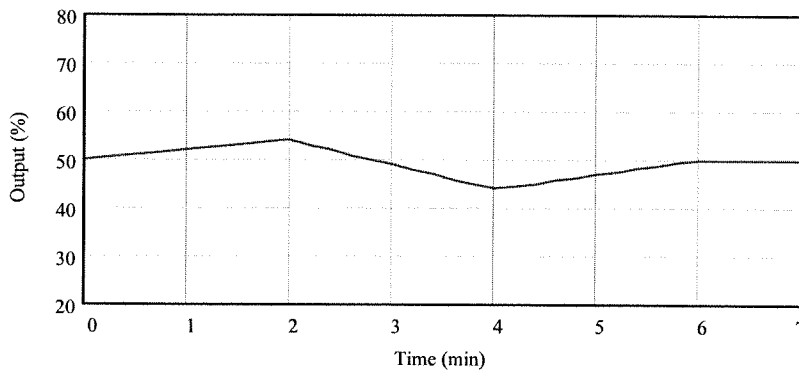

Notice that the output is of the same form as the error.

9.13

The PI controller with $K_p = 2$, $K_i = 2.2 \text{ s}^{-1}$ and $p_i(0) = 40\%$ is governed by the following equation,

$$P = 2e_p + 4.4 \int e_p dt + 40$$

This equation must be evaluated for each of the time sections over which our error curve is defined, as given in the solution to Problem 9.12.

(1) $0 < t < 2$

$$p_1(t) = 2t + 4.4 \int_0^t t dt + 40 = 2t + 4.4 \left[t^2 / 2 \right]_0^t + 40$$

$$p_1(t) = 2t + 2.2t^2 + 40$$

At the end of the period, $t = 2$ seconds the integral term will be given by,

$$p_{11}(2) = 2.2(2)^2 + 40 = 48.8\%$$

(2) $2 < t < 4$

$$p_2(t) = 2(-2.5t + 7) + 4.4 \int_2^t (-2.5t + 7) dt + 48.8$$

$$p_2(t) = -5t + 14 - 11 \left[t^2 / 2 \right]_2^t + 30.8 \left[t - 2 \right]_2^t + 48.8$$

$$p_2 = -5t + 14 - 5.5(t^2 - 4) + 30.8(t - 2) + 48.8$$

At the end of the period, $t = 4$ s, the integral term will be given by,

$$p_{21}(4) = 44.4\%$$

(3) $4 < t < 6$

$$p_3(t) = 2(1.5t - 9) + 4.4 \int_4^t (1.5t - 9) dt + 44.4$$

$$p_3(t) = 3t - 18 + 6.6 \left[t^2 / 2 \right]_4^t - 39.6 \left[t \right]_4^t + 44.4$$

$$p_3(t) = 3t - 18 + 3.3(t^2 - 16) - 39.6(t - 4) + 44.4$$

At the end of the period, $t = 6$ s, the integral term will be given by,

$$p_{31}(6) = 31.2\%$$

These equations are plotted in the following graph. Note the curvature provided by the quadratic terms resulting from the integral action. Note that a reset has occurred since at the end the error is zero but the controller output has not returned to 40%.

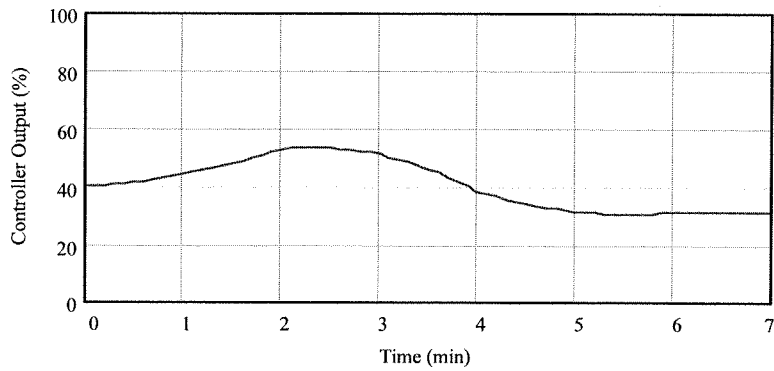

9.14

A PD controller with $K_P = 2$, $K_D = 2$ s and $p_0 = 40\%$ is described by the following equation,

$$p = 2e_p + 4 \frac{de_p}{dt} + 40$$

Using the defined error expressions above the response of the PD controller is described by the following relations:

(1) $0 < t < 2$

$$p_1 = 2t + 4 \frac{d}{dt}(t) + 40$$

$$p_1 = 2t + 44$$

(2) $2 < t < 4$

$$p_2 = 2(-2.5t + 7) + 4 \frac{d}{dt}(-2.5t + 7) + 40$$

$$p_2 = -5t + 14 + 4(-2.5) + 40$$

$$p_2 = -5t + 44$$

(3) $4 < t < 6$

$$p_3 = 2(1.5t - 9) + 4 \frac{d}{dt}(1.5t - 9) + 40$$

$$p_3 = 3t - 18 + 4(1.5) + 40$$

$$p_3 = 3t + 28$$

These relations are plotted below to show the output as a function of time. Note the sharp discontinuities from the derivative term.

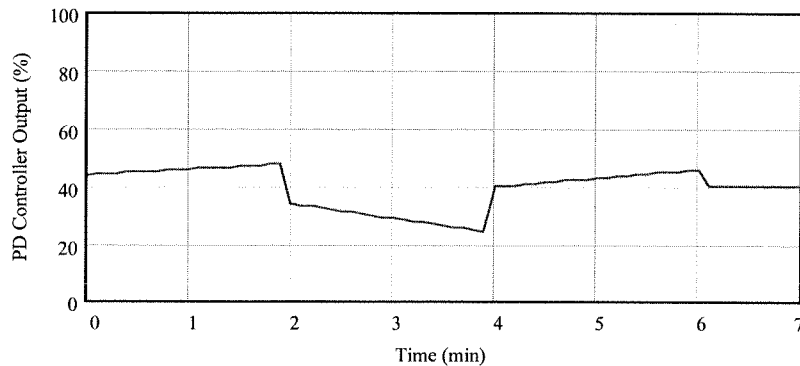

9.15

For the PID controller with $K_P = 2$, $K_I = 2.2$ s⁻¹, $K_D = 2$ s and $p_i(0) = 40\%$ the output equation is,

$$p(t) = 2e_p + 4.4 \int e_p dt + 4 \frac{de_p}{dt} + 40$$

We now substitute the error relations found above for the three sections of the error versus time.

(1) $0 < t < 2$

$$p_1(t) = 2t + 4.4 \int_0^t t dt + 4 \frac{dt}{dt} + 40$$

$$p_1 = 2t + 4.4[t^2/2]_0^t + 4(1) + 40$$

$$p_1 = 2t + 2.2t^2 + 44$$

At the end of the period, $t = 2$ s, the value of the integral term is,

$$p_{11} = 2.2(2)^2 + 40 = 48.8\%$$

(2) $2 < t < 4$

$$p_2(t) = 2(-2.5t + 7) + 4.4 \int_2^t (-2.5t + 7) dt + 4 \frac{d}{dt} [-2.5t + 7] + 48.8$$

$$p_2 = -5t + 14 - 11[t^2/2]_2^t + 30.8[t]_2^t + 4(-2.5) + 48.8$$

$$p_2 = -5t + 14 - 5.5(t^2 - 4) + 30.8(t - 2) + 38.8$$

At the end of the period, $t = 4$ s, the value of the integral term is,

$$p_{21} = 44.4\%$$

(3) $4 < t < 6$

$$p_3(t) = 2(1.5t - 9) + 4.4 \int_4^t (1.5t - 9) dt + 4 \frac{d}{dt} [1.5t - 9] + 44.4$$

$$p_3 = 3t - 18 + 6.6[t^2/2]_4^t - 39.6[t]_4^t + 4(1.5) + 44.4$$

$$p_3 = 3t - 18 + 3.3(t^2 - 16) - 39.6(t - 4) + 50.4$$

At the end of the period, $t = 6$ s, the value of the integral term is,

$$p_{31} = 31.2$$

These relations for the controller output are plotted below. Note the discontinuities introduced by the derivative term. Note the integral reset effect shown by the fact that the output did not return to 40% when the error returned to zero.

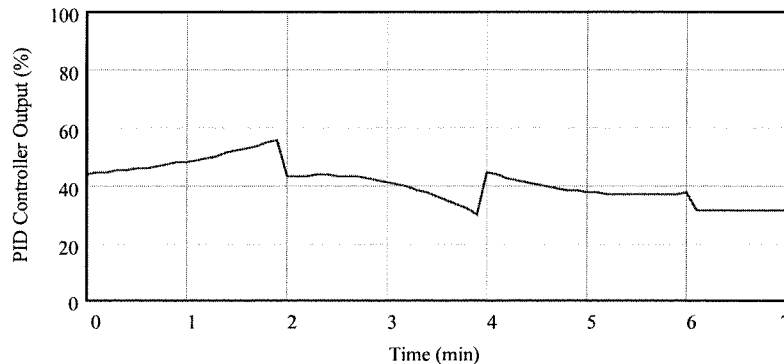

9.16

(a) $PB = 20$ means that $K_p = 100/PB = 100/20 = 5 \%/%$.

(b) 12 repeats per minute simply means $K_i = 12 \%/(\% \cdot \text{min})$

(c) The controller equation, for reverse action, is given by,

$$p = -5e_p - 60 \int_0^t e_p dt + 72$$

If $e_p = 1.5\%$ then this equation becomes,

$$p = -7.5 - 60(1.5)t + 72 = 64.5 - 90t$$

The time to saturate at 0% is found by solving,

$$0 = 64.5 - 90t$$

$$t = (64.5 - 0)/90 = 0.717 \text{ minutes or}$$

$$t = 43 \text{ seconds}$$

9.17

The addition of rate action with $K_D = 0.2$ minutes means the equation for controller output is now,

$$p(t) = -5e_p - 60 \int_0^t e_p dt - 1.0 \frac{de_p}{dt} + 72$$

Of course if the error were +1.5% as in the previous problem the addition of derivative action would have no effect. Now however the error is specified as,

$$e_p = 0.9t^2$$

thus,

$$p = -4.5t^2 - 18t^3 - 1.8t + 72$$

This is a cubic equation in t and we need to know when it goes to zero, i.e., the t for which $p = 0$. This can easily be found from a computer math package which finds the roots of polynomials, or from Newton's root finding on a calculator. If you are desperate, you can simply plot it and find the approximate zero. In any event the answer is 1.488 minutes.

9-18

We start by writing all the equations which describe the behavior of the system. First the equation for PI controller action with the given gains is,

$$p = 0.9e_p + 0.36 \int_0^t e_p dt + p_i(0)$$

The output varies from 3 to 15 psi, so that 0% means 3 psi and 100% means 15 psi. The equation relating controller output, p , and pressure, P in psi, is simply,

$$P = 3 + (15 - 3)p/100 = 3 + 0.12p$$

Thus since at $t = 0$ the output was 10.8 psi (and the error = 0 from Figure 9.25), then,

$$p_i(0) = (P-3)/0.12 = (10.8 - 3)/0.12 = 65\%$$

so the controller equation is,

$$p = 0.9e_p + 0.36 \int_0^t e_p dt + 65$$

Finally the relation between actually flow, Q , and e_p is given by,

$$e_p = 100(60 - Q)/(100 - 20) = 1.25(60 - Q) \%$$

The output as a function of time is found by using the Q from Figure 9.25 to compute the error and then the controller output. The controller output is converted to pressure (psi) and plotted.

The flow has the following characteristics:

TIME	FLOW	ERROR
$0 < t < 2$	$Q_1 = 60 + 5t$	$e_{p1} = -6.25t$
$2 < t < 4$	$Q_2 = 70$	$e_{p2} = -12.5$
$4 < t < 5$	$Q_3 = 150 - 20t$	$e_{p3} = -112.5 + 25t$
$5 < t < 7$	$Q_4 = 50$	$e_{p4} = 12.5$
$7 < t < 9$	$Q_5 = 15 + 5t$	$e_{p5} = 56.25 - 6.25t$
$9 < t$	$Q_6 = 60$	$e_{p6} = 0$

Now the expression for p must be solved in each time period and the corresponding value of pressure, P ,

determined from the simple equation given above. In each case the accumulated value of the integral term, p_i , at the end of the time period is computed as the starting value of the next period.

The results are:

$$p_1 = -5.625t - 1.125t^2 + 65$$

$$p_{i1}(2) = 60.5$$

$$p_2 = -11.25 - 4.5(t - 2) + 60.5$$

$$p_{i2}(4) = 51.5$$

$$p_3 = -101.25 + 22.5t - 40.5(t - 4) + 4.5(t^2 - 16) + 51.5$$

$$p_{i3}(5) = 51.5$$

$$p_4 = 11.25 + 4.5(t - 5) + 51.5$$

$$p_{i4}(7) = 60.5$$

$$p_5 = 50.625 - 5.625t + 20.25(t-7) - 1.125(t^2-49) + 60.5$$

$$p_{5l}(9) = 65$$

$$p_6 = 65 \text{ since the error is now zero.}$$

These expressions are used in $P = 3 + .12p$ to find the pressure in psi. The plot below shows the variation of P with time.

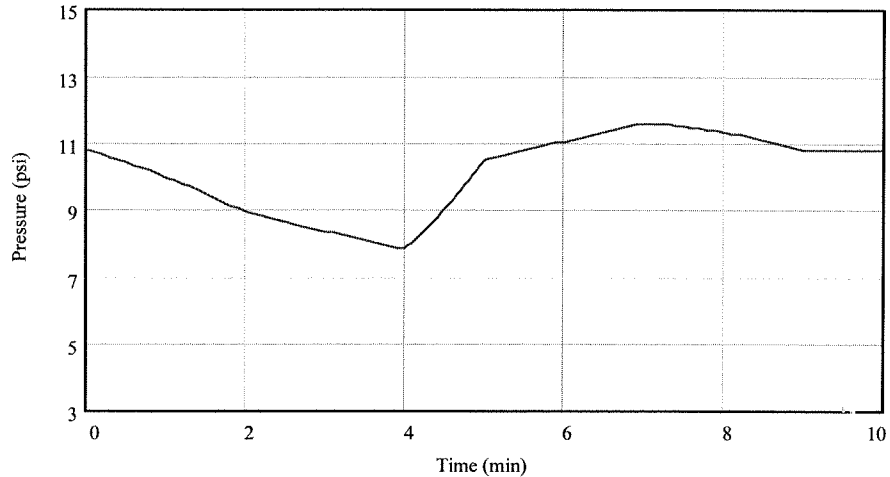

9.19 The controller equation is given by,

$$p = 4.5e_p + 31.5 \int_0^t e_p dt + p_l(0)$$

We take $p_l(0) = 0$ and $e_p = 3\sin(\pi t)$

$$p = 13.5\sin(\pi t) + 94.5 \int_0^t \sin(\pi t) dt$$

$$p = 13.5\sin(\pi t) - (94.5/\pi)[\cos(\pi t)]_0^t$$

$$p = 13.5\sin(\pi t) - 30[\cos(\pi t) - 1]$$

This can be put into the form: $p = A\sin(\pi t + \phi)$ by using the relations,

$$A = [(13.5)^2 + (30)^2]^{1/2} = 32.9$$

$$\text{and } \phi = \tan^{-1}(-30/13.5) = -65.8^\circ$$

thus we have a lag of 65.8°

Supplementary Problems

S9.1

A five degree temperature change is a percent change of $(5/(100-20)) = 6.25\%$ and this occurs in 10 seconds. Therefore the error equation for temperature is

$$e_p(t) = [6.25\%/10s]t = 0.625t \%$$

and it doesn't matter if it is a change from 30 to 35°C or one of 80 to 85°C. But, as noted in the problem statement, the controller reacts to current.

(a) The following plot of current versus temperature clearly shows the non-linear response. The current changes much more for temperature changes in the high range compared to the low.

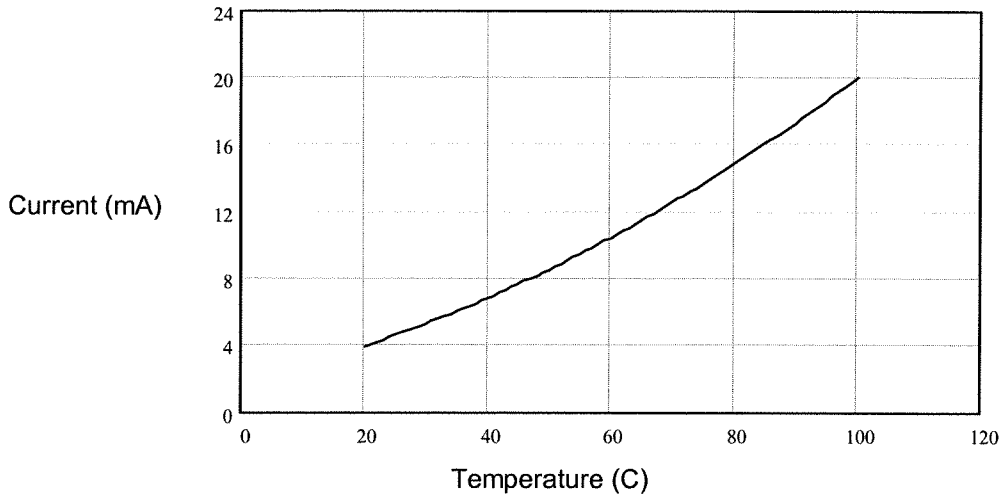

(b) We express the current change by finding the currents at temperatures of 30, 35, 80 and 85°C.

$$I_{30} = 1.91 \left(1 + \frac{30}{44.72} \right)^2 = 5.33 \text{ mA}$$

$$I_{35} = 1.91 \left(1 + \frac{35}{44.72} \right)^2 = 6.07 \text{ mA}$$

$$I_{80} = 1.91 \left(1 + \frac{80}{44.72} \right)^2 = 14.86 \text{ mA}$$

$$I_{85} = 1.91 \left(1 + \frac{85}{44.72} \right)^2 = 16.07 \text{ mA}$$

So in the first case the current change is $\Delta I_{30} = 0.74 \text{ mA}$ and in the second, $\Delta I_{80} = 1.21 \text{ mA}$.

The range of current is of course $\Delta I = 20 - 4 \text{ mA} = 16 \text{ mA}$ so we find the change of current in the two cases as percent of range as,

$$\Delta p_{30} = 0.74/16 = 4.63\% \text{ and } \Delta p_{80} = 1.21/16 = 7.56\%$$

Thus, even though the temperature changed by the same amount in both cases the percent of range change of current was not the same. The controller therefore is fed signals in the two cases that suggests the temperature changed more in the second case.

(c) Since the change occurred in 10 seconds, equations for the two cases are found as,

$$e_{p30}(t) = [4.63\%/10 \text{ s}]t = 0.463t \%$$

$$e_{p80}(t) = [7.56\%/10 \text{ s}]t = 0.756t \%$$

S9.2

Using the given gains and $e_p(t) = Kt$, the general form of the two equations will be,

$$p(t) = 2Kt + K \int_0^t dt + 10 \frac{d}{dt} (Kt) + p(0) = 2Kt + \frac{Kt^2}{2} + 10K + p(0)$$

so we have,

$$p_{30}(t) = 0.463[t^2/2 + 2t + 10] + 30 \text{ and } p_{80}(t) = 0.756[t^2/2 + 2t + 10] + 50$$

We see that the form of controller response is the same in both cases but in the 80°C case the change is larger in magnitude. The following plot shows the response as a function of time.

After 10 seconds the changes are,

$$\Delta p_{30}(10) = 37\% \text{ and } \Delta p_{80}(10) = 60\%$$

Actually in the second case the output saturates at 100% as the plot shows.

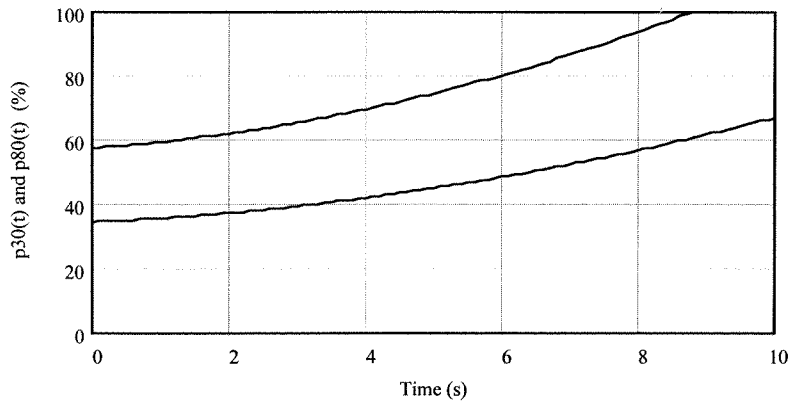

9.3

The PID equation is,

$$p(t) = e_p + \int_0^t e_p dt + \frac{d}{dt}(e_p)$$

Now we set $e_p(t) = \sin(2\pi ft)$. The equation for controller output is found by recalling that,

$$\int \sin(\omega t) dt = -\frac{1}{\omega} \cos(\omega t) \quad \text{and} \quad \frac{d}{dt}[\sin(\omega t)] = \omega \cos(\omega t)$$

Then we have, $p(t) = \sin(2\pi ft) + \frac{1}{2\pi f} [-\cos(2\pi ft)]_0^t + 2\pi f \cos(2\pi ft)$ or

$$p(t) = \sin(2\pi ft) + \left(2\pi f - \frac{1}{2\pi f}\right) \cos(2\pi ft) + \frac{1}{2\pi f}$$

Using the identities given in the problem we write this equation in the form,

$$p(t) = K \sin(2\pi ft + \phi)$$

where,

$$K = \sqrt{1 + \left(2\pi f - \frac{1}{2\pi f}\right)^2} \quad \text{and} \quad \phi = \tan^{-1}\left(2\pi f - \frac{1}{2\pi f}\right)$$

The following two plots show the gain K and phase, ϕ , plotted versus frequency from 0.001 to 100 Hz using a semilog plot. You can see that the gain becomes very large at low and high frequencies.

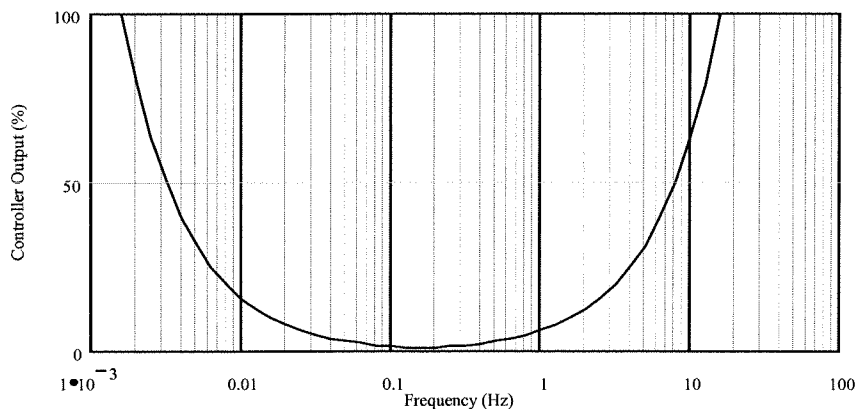

The phase shift goes from -90° to $+90^\circ$

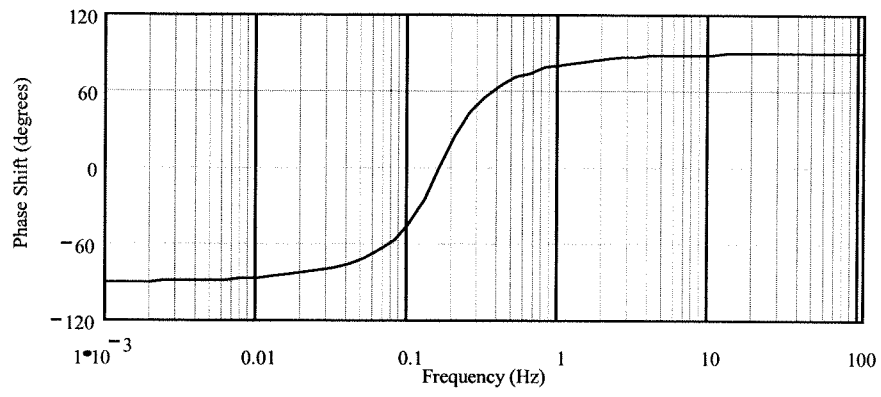

CHAPTER 10

10.1

The relation between position and current is a simple linear equation,

$$I = kx + I_0$$

since $I = 4 \text{ mA}$ when $x = 0$ we must have $I_0 = 4 \text{ mA}$. Then when $x = 2 \text{ m}$ we must have,

$$20 \text{ mA} = 2k + 4 \text{ mA} \text{ or } k = (20 - 4) \text{ mA}/2 = 8 \text{ mA/m}$$

thus, $I = 0.008x + 0.004$ amperes

This current is passed through a 100Ω resistor which results in a voltage given by $V = 100I$. Thus the relation between voltage and position is,

$$V = 0.8x + 0.4 \text{ Volts}$$

(a) a setpoint of 0.85 m means that the voltage will be,

$$V = (0.8)(0.85) + 0.4 = 1.08 \text{ volts}$$

and this must be V_{sp} .

(b) The error voltage is $V_e = V_{sp} - V$. If $V_{sp} = 1.5$ volts then the range of error is,

$$\begin{array}{ll} 0 \text{ m gives } 0.4 \text{ volts} & V_e = 1.5 - 0.4 = 1.1 \text{ volts} \\ 2 \text{ m gives } 2.0 \text{ volts} & V_e = 1.5 - 2.0 = -0.5 \text{ volts} \end{array}$$

10.2

The following circuit shows that we use $R_L = 100 \Omega$ which converts the 4 to 20 mA into 0.4 to 2 volts. By using resistors in the op amp circuit of $100 \text{ k}\Omega$ we keep loading to 1 part in 1000. The output voltage is

$$V_e = V_{sp} - 100I$$

or, in terms of the position,

$$V_e = V_{sp} - 0.8x - 0.4$$

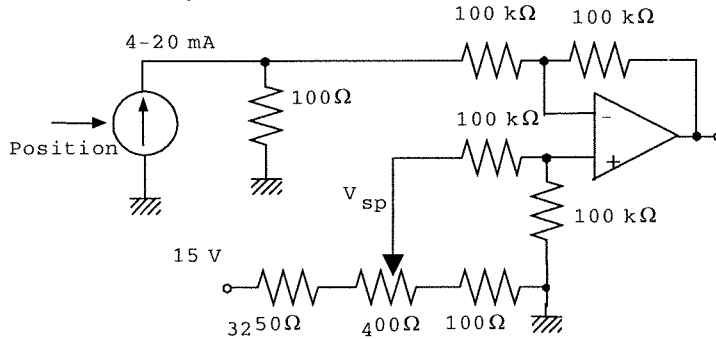

V_{sp} can be set to any value between 0.4 and 2 volts.

10.3

This problem has trip points determined from $V_{sp} \pm \Delta V$. In this case 4.3 ± 1.1 volts, so $V_H = 5.4 \text{ V}$ and $V_L = 3.2 \text{ V}$. The following diagram shows the desired response of the system.

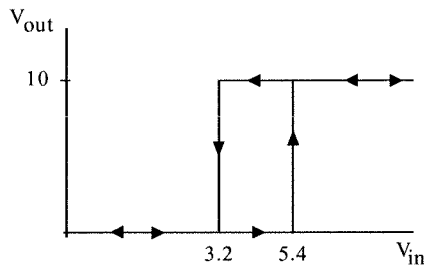

From Equation (10-2), $V_L = 3.2 = 4.3 - (R_1/R_2)10$ or, $R_1/R_2 = 0.22$

We now select resistors to satisfy this relation for the resistors. Suppose we select $R_3 = 2.2 \text{ k}\Omega$ then

$$R_1 = 2.2 \text{ k}\Omega \text{ and } R_2 = 2.2 \text{ k}\Omega/0.22 = 10 \text{ k}\Omega$$

The inverter resistors can be anything in the $\text{k}\Omega$'s, say $10 \text{ k}\Omega$.

10.4

This is an example of a reverse acting two-position controller since the light is to be on when the voltage is low. The basic response desired is,

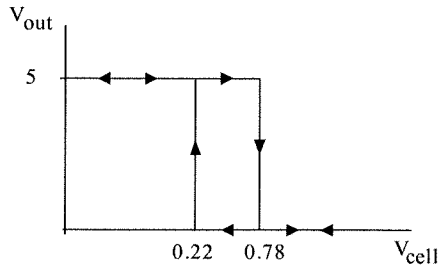

This is just the two-position controller of Figure 10.5 with the output of the comparator passed through an inverter. Thus,

$$V_H = 0.78 = V_{sp}$$

and

$$V_L = 0.22 = V_{sp} - (R_1/R_2)V_0$$

Let us assume TTL output for the comparator, so that $V_0 = 5$ volts. That leaves two resistors to be determined but with only one equation. So we can pick one. Let us pick $R_1 = 1 \text{ k}\Omega$ to keep the currents in the low mA. Then we have,

$$0.22 = 0.78 - 5(1 \text{ k}\Omega)/R_2$$

or

$$R_2 = 5(1 \text{ k}\Omega)/0.56 = 8.93 \text{ k}\Omega$$

The following circuit provides the two position control.

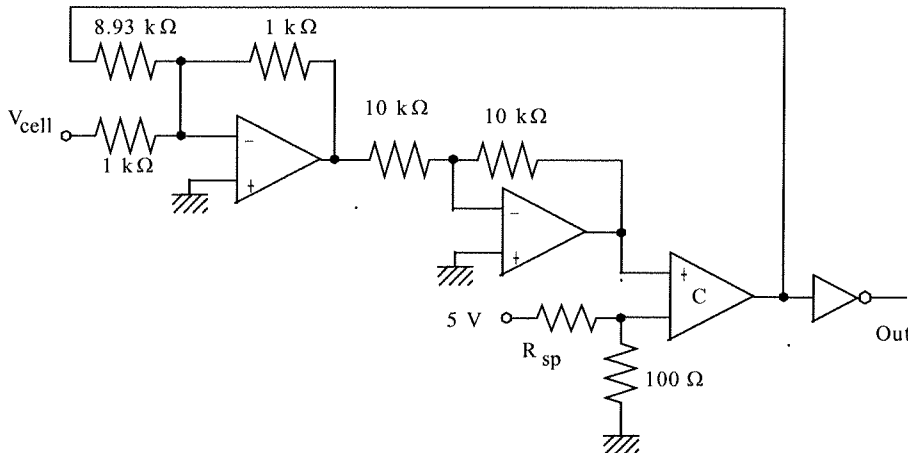

10.5

We use the two-position controller shown in Figure 10.5. Then the output should be 5.0 volts when the temperature reaches 250°C and drops back to 0.0 volts when the temperature drops back to 240°C . Well, the Type J TC produces 13.56 mV at 250°C and 13.01 mV for 240°C , assuming a 0°C reference. Suppose we use a differential amplifier with a gain of 100 so that the voltages become 1.356 V and 1.301 V respectively. Then, according to the design associated with Figure 10.5, we have

$$V_H = 1.356 \text{ V}$$

and
$$V_L = 1.301 = V_H - (R_1/R_2)V_0$$

so,
$$1.301 = 1.356 - (R_1/R_2)(5.0)$$

This gives, $R_1/R_2 = 0.011$, so we pick $R_1 = 1 \text{ k}\Omega$ and then $R_2 = 90.9 \text{ k}\Omega$. We use the following differential amplifier to condition the TC voltage and a simple divider to produce the 1.356 volt setpoint along with the circuit of Figure 10.5.

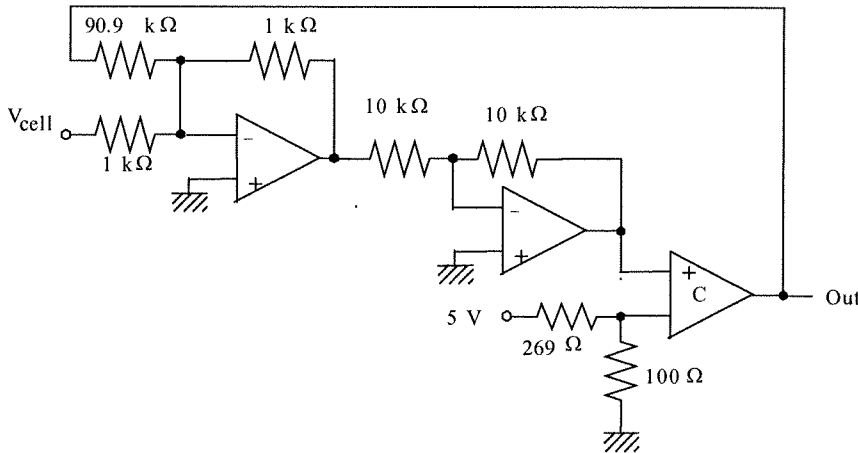
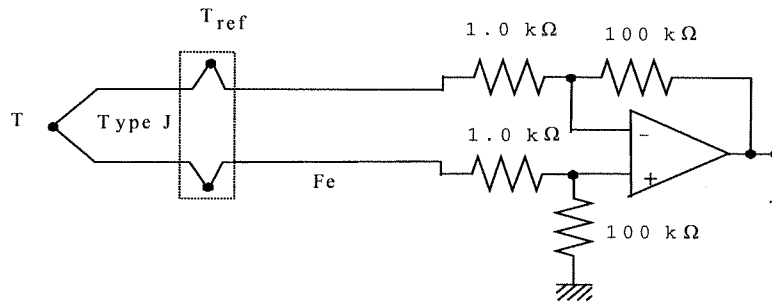

10.6

We can put the thermistor in a divider to convert its resistance change to a voltage and then use the two-position of Figure 10.5. We must keep self-heating below 0.5°C so the maximum power dissipated is found from,

$$P = P_D \Delta T = (5 \text{ mW}/^{\circ}\text{C})(0.5^{\circ}\text{C}) = 2.5 \text{ mW}$$

We want to divider voltage to increase with temperature, but the thermistor resistance decreases with temperature. Therefore we put the thermistor as the upper divider resistance. The maximum currents at the two extremes is given by $I_1 = [2.5 \text{ mW}/1400]^{1/2} = 1.34 \text{ mA}$ and $I_2 = [2.5 \text{ mW}/4700]^{1/2} = 0.73 \text{ mA}$. From Ohm's law we find the resulting divider resistances from,

$$1.34 \text{ mA} = \frac{5}{R + 1400} \quad \text{which gives } R = 2331 \Omega, \text{ or}$$

$$0.73 \text{ mA} = \frac{5}{R + 4700} \quad \text{which gives } R = 2149 \Omega$$

Let's use a 2.5 kΩ resistor to be sure the self-heating is below the specification.

The divider voltages at 35°C and 60°C are,

$$V_{35} = \frac{5(2500)}{4700 + 2500} = 1.736 \approx 1.74 \text{ V}$$

$$V_{60} = \frac{5(2500)}{1400 + 2500} = 3.205 \approx 3.21 \text{ V}$$

It will be necessary to use an inverter on the output of the comparator since we want the output to go low when the temperature reaches 60°C (3.21 volts). We find R_1 and R_2 from,

$$V_0 \frac{R_1}{R_2} = V_{sp} - V_L = 3.21 - 1.74$$

Taking $V_0 = 5$ volts we get

$\frac{R_1}{R_2} = 0.294$ so let's take $R_1 = 10 \text{ k}\Omega$ so that $R_2 = 34 \text{ k}\Omega$. The complete schematic is shown below.

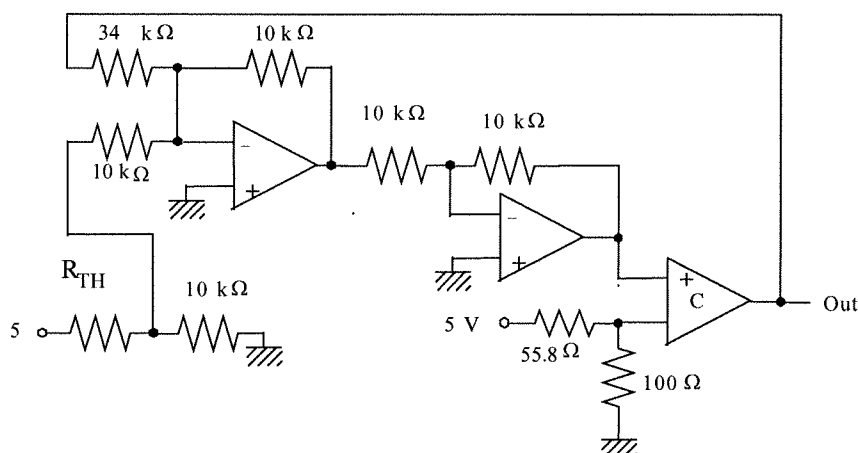

10.7

This problem can be solved in three parts. Part 1 is to convert the speed information into voltage, i.e., measurement and signal conditioning. Part 2 is the error detector and Part 3 is the proportional controller itself. The overall block diagram is,

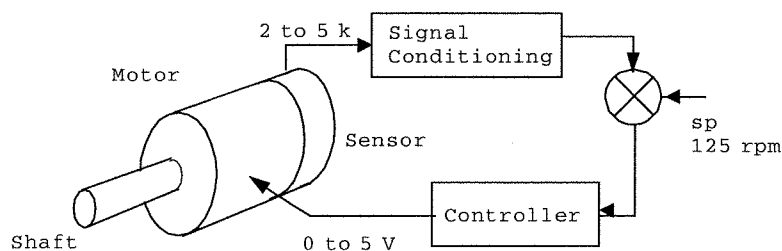

Part 1: To preserve the linearity of the resistive transducer we will use it in the feedback of an inverting amplifier. The relation between speed and sensor resistance can be easily shown to be:

$$R_s = [(3/50)S - 4] \text{ k}\Omega.$$

The following circuit will provide the measurement voltage, V_c .

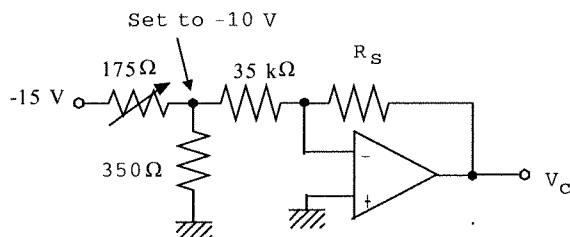

where $V_c = -(R_s/R_f)V_0$

By making $V_0 = -10$ volts and using the $35 \text{ k}\Omega$ we have

$$V_c = 10(R_s/35 \text{ k}\Omega)$$

For $S = 100 \text{ rpm}$, $R_s = 2 \text{ k}\Omega$ and $V_c = 0.571$ volts

For $S = 125 \text{ rpm}$, $R_s = 3.5 \text{ k}\Omega$ so $V_c = 1.000$ volts

For $S = 150 \text{ rpm}$, $R_s = 5 \text{ k}\Omega$ and $V_c = 1.429$ volts

Part 2: For an error detector let us use a differential amplifier. We must make the connections so that the response is,

$$V_e = V_{sp} - V_c$$

where $V_{sp} = 1.0$ volts can be provided by a divider. The following circuit will satisfy this equation except the output is seen to actually be $-V_e$ as defined above.

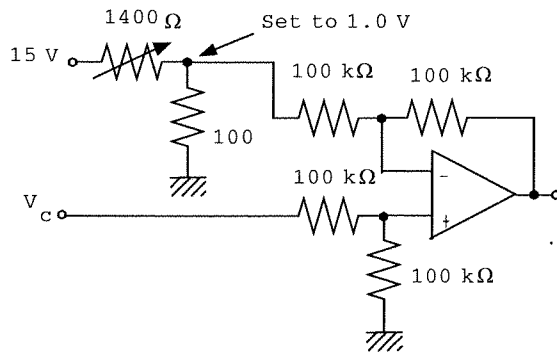

Part 3: The proportional controller must act in such a way so that if the speed goes high then the output is decreased. Ok, let's see how this works out. If the speed is high then $V_c > V_{sp}$ so that $V_e < 0$. But from the differential amplifier we get $-V_e$ so that the input to the proportional controller will be $>$. This is good since the proportional controller is an inverting amplifier. From this logic you can see that the following circuit will work.

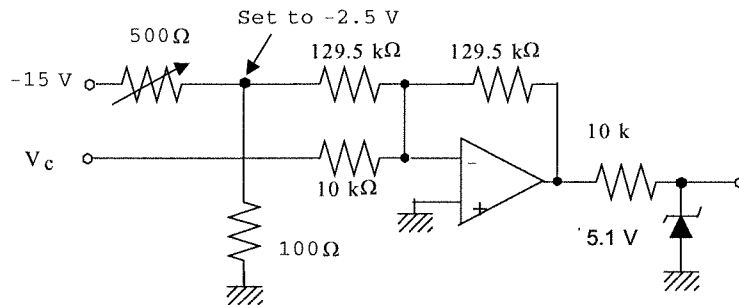

$$V_{out} = V_0 - (R_f/R_3)V_e$$

But since the output of the error detector is $-V_e$ we have $V_{out} = V_0 + (R_f/R_3)V_e$. Thus if the speed is high and $V_e < 0$ it will decrease the output as required.

The proportional band is given to be 45%. Therefore when the error changes by 45% of its range the output changes by 100% of its range.

$$\Delta V_e = 0.45(1.429 - 0.571) = 0.3861 \text{ volts } \Delta V_{out} = 5 \text{ volts}$$

Thus the voltage gain is $G_V = 5/0.3861 = 12.95$ and so, $(R_f/R_2) = 12.95$

so $R_3 = 10 \text{ k}\Omega$ then $R_f = 129.5$, and $V_0 = -2.5$ volts. The controller equation is,

$$V_{out} = 2.5 + 12.95V_e$$

(b) We assume the 0 to 5 volts nominally produces 100 to 150 rpm. This means that the equation relating speed and output voltage is,

$$S = 10V_{out} + 100$$

So, a speed of 120 rpm means we need $V_{out} = 2.0 \text{ V}$. To get this from the controller we will need an error,

$$2.0 = 2.5 + 12.95V_e$$

$$V_e = -0.0386 = V_{sp} - V_c = 1 - V_c$$

$$V_c = 1.0386 = 10(R_s/35 \text{ k}\Omega)$$

$$R_s = 3.635 \text{ k}\Omega = [(3/50)S - 4] \text{ k}\Omega$$

$$S = 127.25 \text{ rpm}$$

The offset error is 2.25 rpm or about 4.5% of span

10.8

Since the full scale input range of the controller and output range are both specified, the controller can be easily specified from Figure 10.7 and associated equations. The input range is 1 volt so the 35% PB means that for an input change of $(0.35)(1 \text{ volt}) = 0.35$ volts the output should change of 100% or 10 volts. Thus the voltage gain is,

$$G_V = 10/0.35 = 28.57$$

The zero error output is to be 45% of the output range or simply 4.5 volts. Referring to the controller circuit as shown in Figure 10.7, if we pick $R_f = 3.5 \text{ k}\Omega$ then $R_2 = 100 \text{ k}\Omega$ and we use a

divider to make $V_o = 4.5$ volts. An inverter is shown in Figure 10.7 because the controller circuit is an inverter. We will design to provide $-V_e$ as an input so no extra inverter is needed.

For the measurement and error system we need a differential amplifier for the TC signal and then some kind of error detector. The temperature range is 100 to 180 °C and this range must produce a range of 1 volt. For the Type J TC with a 0 °C reference this temperature range corresponds to voltages from 5.27 mV to 9.67 mV or a range of 4.4 mV. Thus the required gain is,
 $G = 1/0.0044 = 227.3$

The setpoint TC voltage is 7.45 mV for an output voltage of $V_{sp} = 0.00745(227.3) = 1.69$ volts. The following circuit provides the required amplification and error detection using a summing amplifier. It provides an output of $-V_e$.

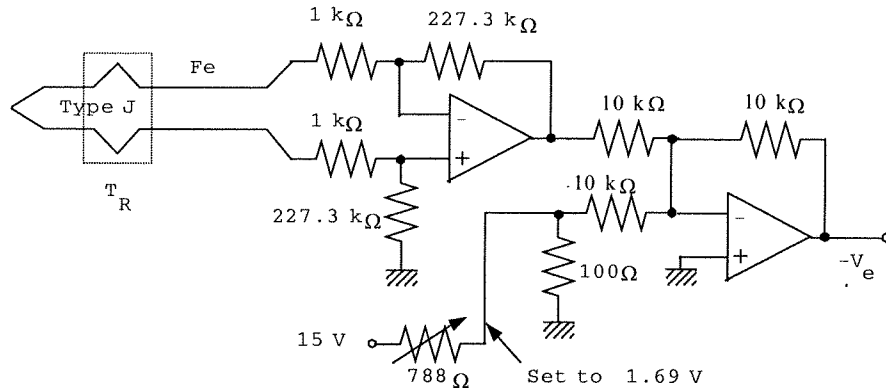

The controller circuit from Figure 10.7 is given below.

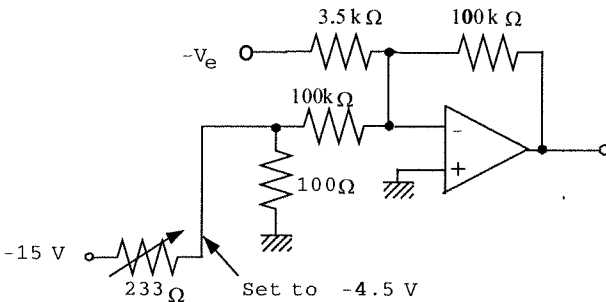

Where no inverter on the output is required.

10.9

A K_i of 12 %/(%-min) means that if the input changes by 1% of its range for 1 minute (60 seconds) then the output should change by 12% of its range. For the integral controller the gain is determined by,

$$G_i = 1/(RC)$$

which is in sec^{-1} . Therefore we should express K_i in terms of seconds.

$$K_i = 12 \text{ \%}/(\text{\%-min}) \times (1 \text{ min}/60 \text{ s}) = 0.2 \text{ \%}/(\text{\%-s})$$

now we find,

$$G_i = (0.002)(12)/[(0.01)(7)] = 0.024/0.07$$

$$G_i = .343 \text{ s}^{-1}$$

so,

$$RC = 2.92$$

we pick $C = 10 \mu\text{F}$ so $R = 292 \text{ k}\Omega$

10.10

The required gain is $K_D = 0.02 \text{ \%}/(\text{\%/min})$ where the input range is -4.0 to +4.0 volts or 8 volts and the output range is 2.5 volts. We need the gains expressed in terms of voltage gain instead of percent.

$K_D = 0.02\%/(\%/min)(60 \text{ s/min}) = 1.2\%/(\%/s)$
 1%/s of the input range is $(0.01s^{-1})(8 \text{ V}) = 0.8 \text{ V/s}$ and 1.2% of the output is $(0.012)(2.5) = 0.03 \text{ V}$.
 Thus we can find the gain as,

$$G_D = 0.03 \text{ V}/(0.8 \text{ V/s}) = 0.0375 \text{ s}$$

The circuit of Figure 10.15 and associated equations show that $G_D = R_2C$. Let's pick $C = 0.5 \text{ mF}$ so then $R_2 = 75 \text{ k}\Omega$

The value of R_1 is found from the limitation imposed on derivative circuits,

$$2\pi f_{max}R_1C \leq 0.1$$

In this case we are given that $T_{min} = 0.4 \text{ min} = 24 \text{ s}$ so that $f_{max} = 0.042 \text{ Hz}$. Thus we find,

$$R_1 = \frac{0.1}{2\pi(0.042 \text{ s}^{-1})(0.5 \mu\text{F})} \approx 760 \text{ k}\Omega$$

10.11

The actual circuit gains are found by conversion of the PB and reset time into values appropriate to the circuit. The 80% PB means that if the input changes by 80% of its range, or, $0.8(5) = 4.0$ volts then the output must change by 100% of its range, or, 12 volts. This means the circuit gain is,

$$G_P = 12/4 = 3$$

The 0.03 min reset time means that the integral gain is given by,

$$K_I = 1/T_I = 1/0.03 = 33.33 \%/(\%-min)$$

We convert this to seconds so that it will be more appropriate to the circuit,

$$K_I = (1 \text{ min}/60 \text{ s})[33.33 \%/(\%-min)]$$

$$K_I = 0.5556 \%/(\%-s)$$

The interpretation of this number is that if the input changes by 1% of its range for 1 s, then the output must change by 0.556% of its range. Thus,

$$G_I = (0.005556)(12)/[(0.01)(5)]$$

$$G_I = 1.333 \text{ s}^{-1}$$

Using the circuit of Fig. 10.13 we make,

$$R_2/R_1 = 3 \quad 1/R_2C = 1.333$$

If we select $C = 2 \mu\text{F}$ then $R_2 = 375 \text{ k}\Omega$ and so we must have $R_1 = R_2/3 = 125 \text{ k}\Omega$. The inverter resistance can be any convenient value, say $10 \text{ k}\Omega$.

10.12

We use the circuit of Fig. 10-14. The component values are determined by interpretation of the gains in terms of the circuit. The input range is $\Delta V_{in} = 2 - 0.4 = 1.6$ volts and the output range is 10 volts.

A 140% PB means that the output must change by 1% of 10 volts, or 0.1 volts when the input changes by 140% of its range or $(1.4)(1.6) = 2.24$ volts. Thus,

$$G_P = 0.1/2.24 = 0.045$$

A 0.2 minute derivative time means $K_D = 0.2 \text{ min} = 12 \text{ s}$. This means that if the input changes at a rate of 1%(of range)/second = 0.016 V/s then the output must change by 12 % of 10 volts or 0.12 volts. Thus,

$$G_D = 1.2/0.016 = 75 \text{ s}$$

Figure 10.14 shows a PD controller using op amps. The associated equations for the components provide the relations,

$$G_P = R_2/(R_1 + R_3)$$

$$G_D = R_3C$$

and, for stability,

$$R_1R_3C/(R_1 + R_3) = 0.1T/2\pi$$

These are three equations for four unknowns. This means that one can be selected and the others calculated. Suppose we take $C = 1 \mu\text{F}$. The second equation then gives,

$$R_3C = 75 \text{ or } R_3 = 75/1\mu\text{F} = 75 \text{ M}\Omega$$

This size of resistance could create problems of noise, so let's try $C = 100 \mu\text{F}$, then $R_3 = 750 \text{ k}\Omega$. From the last equation above, with $T = 1 \text{ min} = 60 \text{ s}$,

$$7.5R_1/(R_1 + 750 \text{ k}\Omega) = 6/2\pi = 0.955 \quad R_1 = (0.955)(750 \text{ k}\Omega)/(7.5 - 0.955)$$

$$R_1 = 11 \text{ k}\Omega$$

Now the first equation provides,

$$R_2 = G_P(R_1 + R_3) = 87.5(11 \text{ k}\Omega + 75 \text{ k}\Omega) \quad R_2 = 7.5 \text{ M}\Omega$$

10.13

We assume the current can be passed to ground. So the current is passed through a 100 Ω resistor to produce a voltage from 0.4 to 2.0 volts. This means that the input range is 1.6 volts. Now a differential amplifier with unity gain is used to produce the error voltage, V_e . The setpoint voltage, V_{sp} , is taken from a voltage divider and variable resistor which can provide any voltage between 0.4 and 2.0 volts. The following circuit provides these functions.

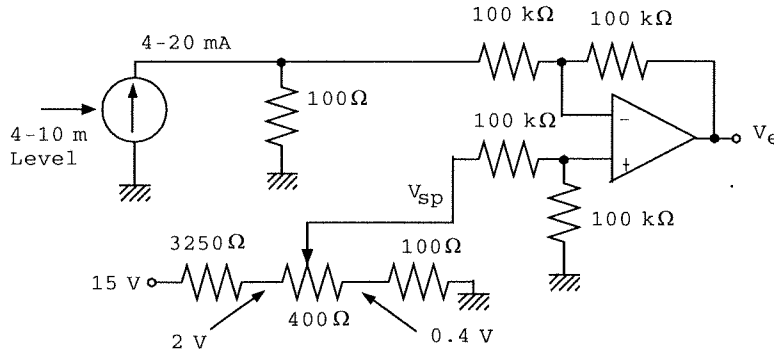

For the PID controller we use the circuit of Figure 10.15 and the gain equations of Equation (10-10) along with the stability condition, $2\pi R_3 C \ll T$. Now the controller gains must be used to determine the appropriate circuit gains. A 50% PB means that if the error changes by 50% or 0.8 volts the output must change by 100% or 5 volts. Thus,

$$G_P = R_2/R_1 = 5/0.8 = 6.25$$

A 0.03 min reset time means that $T_I = (0.03 \text{ min})(60 \text{ s/min}) = 1.8 \text{ s}$

or

$$K_I = 0.556 \text{ \%}/(\text{\%-s})$$

So, if the error is 1%, or 0.016 volts, for 1 second the output must change by 0.556% or 0.0278 volts. This provides a circuit gain of,

$$G_I = 1/(R_1 C_I) = 0.0278/0.016 = 1.74 \text{ s}^{-1}$$

The derivative time is $T_D = K_D = 0.05 \text{ min} = 3 \text{ s}$, so,

$$K_D = 3 \text{ \%}/(\text{\%/s})$$

Thus an error of 1 %/s (0.016 V/s) should produce an output of 3% or 0.15 volts. The circuit gain is,

$$G_D = R_D C_D = 0.15/0.016 = 9.375 \text{ s}$$

The fastest change time is given as $T = 0.8 \text{ min} = 48 \text{ s}$. If we use a factor of ten safety then,

$$2\pi R_3 C_D = 0.1 T = 4.8 \text{ s}$$

Components are now selected to satisfy the three gain equations and stability equation given above. Our selections are,

$$\begin{aligned} R_1 &= 10 \text{ k}\Omega & R_2 &= 62.5 \text{ k}\Omega \\ C_I &= 1 \text{ }\mu\text{F} & R_I &= 575 \text{ k}\Omega \\ C_D &= 10 \text{ }\mu\text{F} & R_D &= 938 \text{ k}\Omega \\ R_3 &= 76 \text{ k}\Omega \end{aligned}$$

10.14

The pneumatic proportional controller has an equation,

$$p_{out} = (x_1/x_2)(A_1/A_2)(p_m - p_{sp}) + p_o$$

In this case the areas are equal so that the gain is provided by the pivot arm ratio alone. A 23% PB means that when the input changes by 23% of its range the output must change by 100% of its range. Since input and output ranges are the same we have,

$$(x_1/x_2) = K_P = 100/23 = 4.35$$

10.15

The equation becomes,

$$\begin{aligned} p_{out} &= 4.35(p_m - 7) + 9.2 \text{ psi solving,} \\ p_m &= 7 + (p_{out} - 9.2)/4.35 \end{aligned}$$

For $p_{out} = 3 \text{ psi}$,

$$p_m = 7 + (3 - 9.2)/4.35 = 5.57 \text{ psi}$$

and for 15 psi,

$$p_m = 7 + (15 - 9.2)/4.35 = 8.33 \text{ psi}$$

Note that $100(8.33 - 5.57)/(15 - 3) = 23\%$ as required.

10.16

To change the setpoint to 90 lux we need to determine how much voltage will be generated by the measurement for 90 lux. We have,

$$V_m = R/13 \text{ k}\Omega \quad \text{in volts}$$

A light level of 90 lux will produce a resistance of,

$$R = 10 \text{ k}\Omega - (120 \text{ }\Omega/\text{lux})(90 - 100) = 11.2 \text{ k}\Omega$$

so, $V_m = 11.2/13 = 0.86$ volts

A 90 lux setpoint can be provided by changing the 1 volt at the summing amplifier to 0.86 volts. The 48% PB is provided by changing the gain so that an input change of 48% or $0.48(1.382) = 0.66$ volts produces a 100% output change or 10 volts. Thus,

$$G_p = 10/0.66 = 15$$

This can be provided by changing the 9.63 k Ω resistor to 15 k Ω .

10.17

Switched reset times can be provided by using a set of capacitors in the feedback with an appropriate switch. For the first case, 0.02 min, we have $T_I = 0.02 \text{ min} = 1.2 \text{ s}$ so that

$$K_I = 0.8333 \text{ \%}/(\text{\%-s})$$

This means that the circuit gain is,

$$G_I = 1/(R_2 C) = 0.8333(12)/5 = 2 \text{ s}^{-1}$$

From Problem 10.10 we need $R_2 = 375 \text{ k}\Omega$ and $R_1 = 125 \text{ k}\Omega$ to get the 80% PB. Then

$$C = 1/(375 \text{ k}\Omega G_I)$$

Using this same resistor and varying the capacitors provides the results, below

T_I	K_I	G_I	C
0.02 min	0.833 s ⁻¹	2 s ⁻¹	1.33 μF
0.04	0.417	1	2.67
0.06	0.278	0.667	4
0.08	0.208	0.5	5.33

The following circuit shows how this is provided.

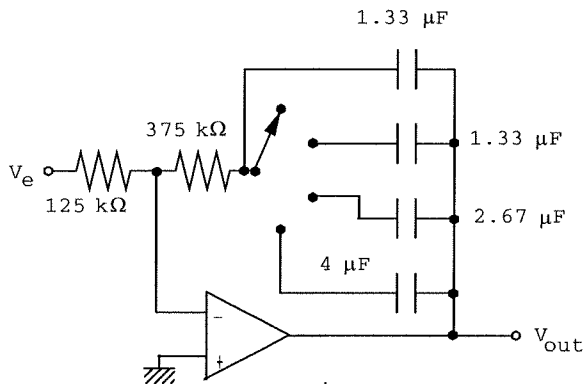

10.18

Well, first we pass the current through a 100 Ω resistor to produce a measurement voltage of 0.4 to 2.0 volts. Then this is used with a differential amplifier to produce the error voltage. The setpoint is provided from a divider with a variable resistor so that V_{sp} can be varied from 0.4 to 2.0 volts. This is shown in the following error detector circuit.

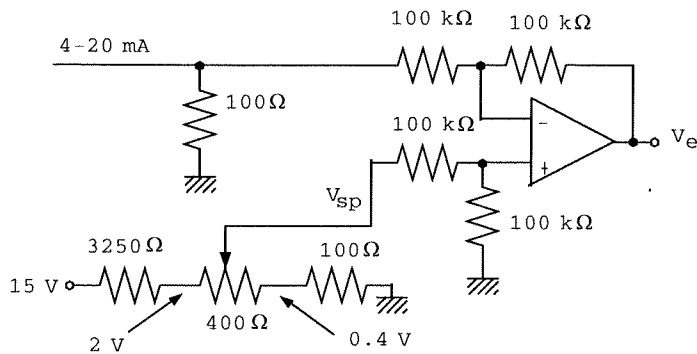

The zero error output adjustable from 0 to 100% is provided by a divider with a variable resistor which taps from 0 to 9 volts. To provide for variable K_P from 1 to 10 we will use a fixed resistor (R_0) in series with a variable resistor. The circuit gain will range from,

$$G_P = (1\% \text{ of } 9)/(1\% \text{ of } 1.6) = 5.625$$

to

$$G_P = (10\% \text{ of } 9)/(1\% \text{ of } 1.6) = 56.25$$

The circuit gain is determined by the resistor ratios as shown for the circuit of Figure 10.9: $G_P = (R_2/R_1)$ We will vary the gain by variation of R_1 . We make R_1 as a fixed resistor, R_0 , in series with a variable, R_v . The minimum gain above will occur when $R_1 = R_0 + R_v$, i.e., R_v is at its maximum, and minimum gain when $R_1 = R_0$ with $R_v = 0$. The following equations set this up,

$$R_2/(R_0 + R_v) = 5.625$$

$$R_2/R_0 = 56.25$$

There are three unknowns and two equations, so we can pick one of the resistors. Let's use $R_v = 20 \text{ k}\Omega$ (variable) since this a common value for a variable resistor. Then we can solve for the others, $R_0 = 2222 \Omega$ and $R_2 = 125 \text{ k}\Omega$. The following circuit shows the controller with variable proportional gain.

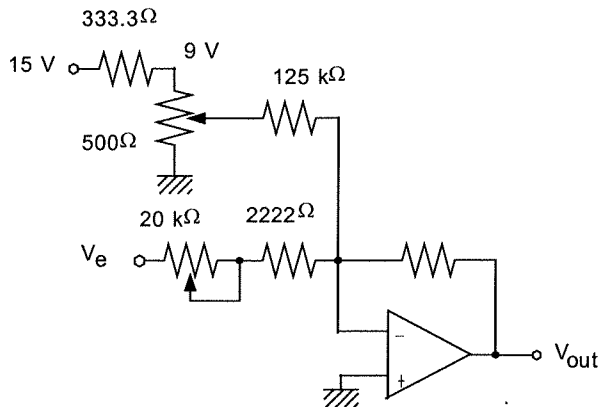

10.19

Let's start with the measurement and error detection system. A range of 0 to 300 psi at 22 mV/psi means the voltage range from the transducer is 0 to $(0.022 \text{ V/psi})(300 \text{ psi}) = 6.6$ volts. If we use a unity gain error detector it also means that the setpoint voltage must vary from

$$V_{sp}(\text{low}) = (0.022 \text{ V/psi})(100 \text{ psi}) = 2.2 \text{ volts}$$

to

$$V_{sp}(\text{high}) = (0.022 \text{ V/psi})(200 \text{ psi}) = 4.4 \text{ volts}$$

So, we use the standard differential amplifier with a variable divider to provide the setpoint voltage. For the PI controller we will use the circuit of Figure 10.13 but with variable resistors to determine K_P and switched capacitors to determine K_I . Since R_2 is in both gains we will vary R_1 to vary the proportional gain.

The proportional gain must be variable from 1.5 to 5 %/%. Given the input voltage range of 6.6 volts and the output range of 10 volts this translates into a circuit gain, G_P , of

$$G_P(\text{low}) = (1.5)(10)/6.6 = 2.273$$

and

$$G_P(\text{high}) = (5.0)(10)/6.6 = 7.576$$

so,

$$R_2/R_{1low} = 2.273 \text{ or } R_{1low} = R_2/2.273 \text{ and}$$

$$R_{1high} = R_2/7.576$$

We would like to use a standard value for the variable resistor. Since R_1 will be composed of a fixed (R_0) in series with the variable (R_v) let us form the relations,

$$R_0 + R_v = R_2/2.273$$

$$R_0 = R_2/7.576$$

The integral gains are provided by $G_I = 1/(R_2C)$. As an example, for $K_I = 0.8 \text{ min}^{-1} = 0.0133 \text{ s}^{-1}$, we have,

$$G_I = (0.01333)(10)/6.6 = 0.02 \text{ s}^{-1}$$

thus,

$$R_2C_1 = 1/0.0202 = 49.5$$

For the other gains we use the same procedure to find,

$$R_2C_2 = 1/0.0404 = 24.8$$

$$R_2C_3 = 1/0.0606 = 16.5$$

$$R_2C_4 = 1/0.0808 = 12.4$$

Now, putting this all together let's try $R_v = 200 \text{ k}\Omega$. Then we can solve for R_2 and R_0 from the proportional gain equations, putting $R_0 = R_2/7.576$ into the first equation gives,

$$R_2/7.576 + 200 \text{ k}\Omega = R_2/2.273$$

thus,

$$R_2 = 649.5 \text{ k}\Omega \text{ and } R_0 = 85.7 \text{ k}\Omega$$

The values of the capacitors are,

$$C_1 = 49.5/649.5 \text{ k}\Omega = 76.2 \mu\text{F}$$

$$C_2 = 24.8/649.5 \text{ k}\Omega = 38.2 \mu\text{F}$$

$$C_3 = 16.5/649.5 \text{ k}\Omega = 25.4 \mu\text{F}$$

$$C_4 = 11.0/649.5 \text{ k}\Omega = 19.1 \mu\text{F}$$

NOW, we would probably go ask how important it was to have these exact gains. If it was satisfactory to have the approximate values then we would use more standard values for the capacitors. The circuit is as follows.

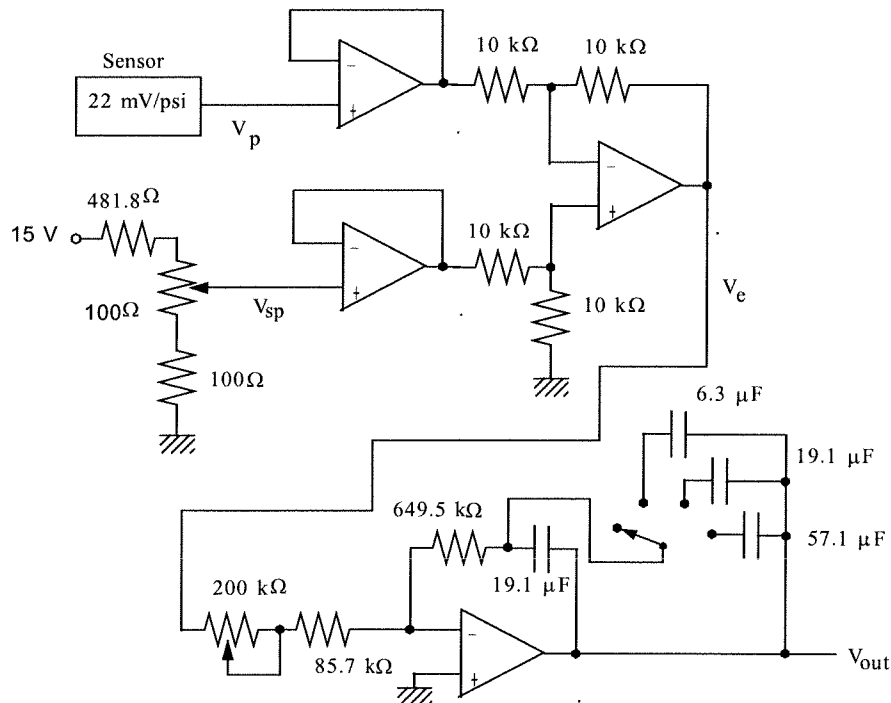

Supplementary Problems

S10.1

This is a reverse acting controller since as the intensity increases the light source voltage should be decreased.

We first set up the error detector. To get the average light intensity we put the two photocells in dividers and use a summing amplifier with a gain of 1/2. For each divider we pick -5.0 volts for the supply and 1.8 k Ω resistors for the rest of the divider. The photocell will be to ground. For the light intensities of interest we find:

I_L (mW/cm ²)	R_{cell} (k Ω)	V_D (V)
20	2.9	-3.085
58	1.25	-2.049
80	0.8	-1.538

The output of the summing amplifier will be, $V_L = -(V_{D1} + V_{D2})/2$. Sensor voltage is negative and drops as light intensity increases so V_L will vary from +3.085 volts when the intensity is low to +1.538 when the intensity is high.

For an error detector we use a differential amplifier with V_L on one input and a fixed 2.049 volts on the other input. The output of the error detector will be,

$V_e = (2.049 - V_L) = [2.049 + (V_{D1} + V_{D2})/2]$ but since the divider voltages are negative we get, $V_e = [2.049 - |V_L|]$

So, as the intensity gets larger than the error voltage becomes more positive.

Now, for the PI controller we are given that $K_p = 1.06\%/%$ and $T_I = 1.67$ s. To convert these to circuit gains we note that the input range is $\Delta V_e = 1.547$ V and the output range is 10 volts. Thus,

1% of the error range is 0.01547 V and 1.05% of the output is 0.106 V, so the proportional circuit gain is,

$$G_p = (0.106 \text{ V}) / (0.01547 \text{ V}) = 6.85 \text{ V/V}$$

For the integral term we have $K_I = 1/T_I = 0.6\%/(\text{-s})$ so 0.6% of the output of 0.06 V and 1%-s of the input is 0.01547 V-s and thus the integral circuit gain is,

$$G_I = (0.06 \text{ V}) / (0.01547 \text{ V-s}) = 3.88 \text{ V/V-s}$$

These are related to the circuit component values by the relations,

$$R_2/R_1 = 6.85 \text{ and } 1/(R_2C) = 3.88$$

We pick $R_1 = 100$ k Ω , then $R_2 = 685$ k Ω and $C = 0.38$ μ F. Since the controller is to be reverse acting we do not put an inverter with the PI circuit. The final circuit is,

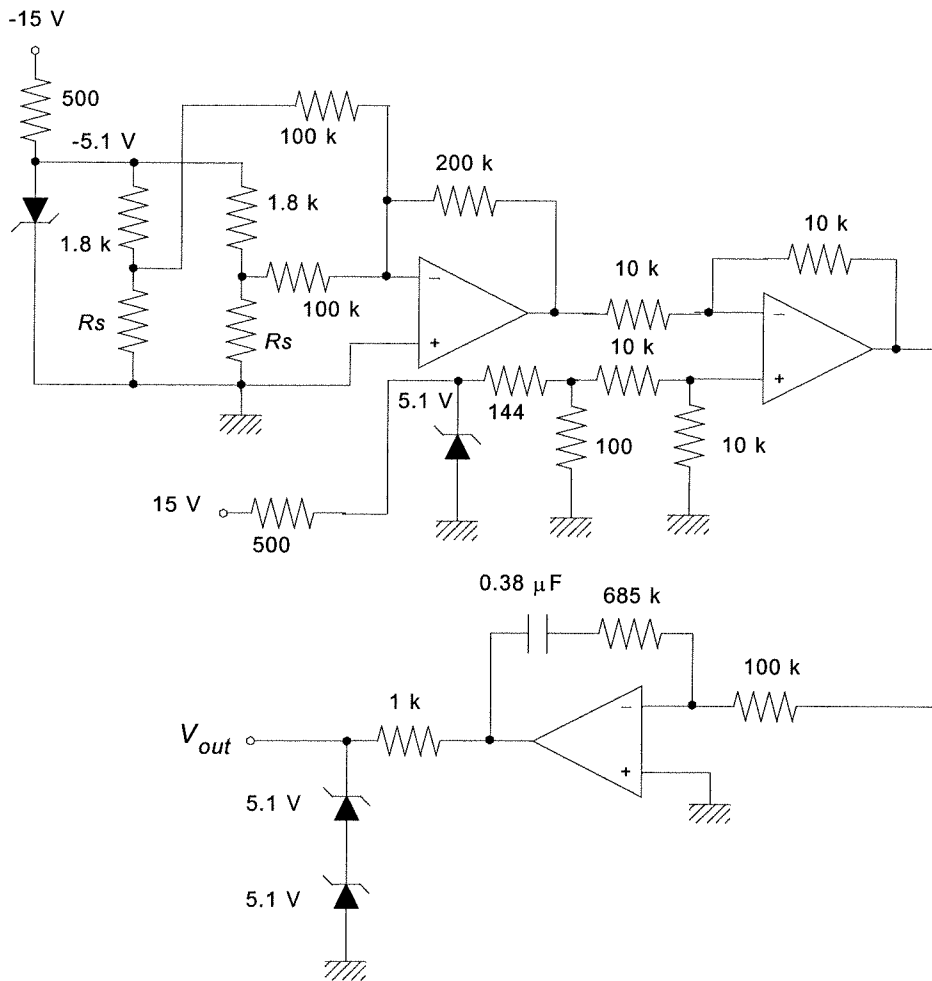

S10.2

(a) The graph of nozzle/flapper pressure versus gap distance is given in Figure 10.28. This shows that to get an output pressure of 50 kPa the gap must be 1.2 mm.

(b) The pressure exerted by the bellows on the flapper is given by, $F = pA$. In this case the area is given to be 7 mc^2 and the pressure is 50 kPa so the force is,

$$F = pA = (50 \times 10^3 \text{ Pa})(7 \times 10^{-4} \text{ m}^2) = 35 \text{ N}$$

Since there are 4.448 N/lb we find this is equivalent to about 7.9 lbs.

(c) If the input changes to 60 kPa that is a change of 10 kPa so we find the change in force as,

$$\Delta F = (10 \times 10^3 \text{ N/m}^2)(7 \times 10^{-4} \text{ m}^2) = 7 \text{ N}$$

This force develops a torque about the pivot of $\tau = Fx = (7 \text{ N})(5 \text{ cm}) = 35 \text{ N-cm}$. The torque must be balanced by an increase in output pressure and increase in force from the output bellows.

$$\Delta F = \tau/x = 35 \text{ N-cm}/2.5 \text{ cm} = 14 \text{ N}$$

In order to get this additional force a pressure increase will be required,

$$\Delta p = \Delta F/A = 14 \text{ N}/(7 \times 10^{-4} \text{ m}^2) = 20 \text{ kPa}$$

Therefore the pressure on the output must increase from 50 kPa to 70 kPa.

(d) The new gap is found from Figure 10.28 to be 1.05 mm. The actual rotation is found from the equation for arc length, $\Delta x = r\theta$ or $\theta = \Delta x/r = 0.15 \text{ mm}/2.5 \text{ cm} = \text{radians}$.

S10.3

The setpoint between 30 and 60 cm/min is converted into a voltage with a scale factor of 0.07 V/(cm/min). Therefore the voltage range is from 2.1 to 4.2 volts. Thus the input range is 2.1 volts.

The output range is given to be 8.0 volts. Now the gains can be converted into circuit voltage gains and the values of components determined.

If $K_P = 3.5\%/%$ it means that a 1% change in input, $0.01(2.1 \text{ V}) = 0.021 \text{ V}$, must produce a 3.5% change in output, $(0.035)(8 \text{ V}) = 0.28 \text{ V}$. Thus the circuit gain is,

$$G_P = (0.28 \text{ v}) / (0.021 \text{ V}) = 13.3 \text{ V/V}$$

In a similar way for the derivative gain, $K_D = 0.006 \text{ min} = 0.36 \text{ s}$, we have a rate of 1%/s of the input,

or 0.021 V/s , producing a 0.36% change in output, $(0.0036)(8 \text{ V}) = 0.0288 \text{ V}$. Thus the derivative circuit gain is,

$$G_D = (0.0288 \text{ V}) / (0.021 \text{ V/s}) = 1.32 \text{ s}$$

Using Figure 10.17 and associated equations for a guide, we can form the equations,

$$G_P = 13.3 = \frac{R_2}{R_1 + R_3} \quad \text{and} \quad G_I = 1.37 = R_3 C$$

We also have a requirement regarding clamping the derivative response at higher frequencies. For this we have a minimum time period of 0.01 min or 0.6 s, so the maximum frequency is $f_{max} = 1.67 \text{ Hz}$.

This gives another equation,

$$2\pi f_{max} \frac{R_1 R_3}{R_1 + R_3} C = 0.1$$

Let's try $C = 10 \mu\text{F}$. Then from the integral gain we get $R_3 = 137 \text{ k}\Omega$. When this is used in the last equation we find $R_1 = 962 \Omega$. Then the proportional gain equation tells us that $R_2 = 1.89 \text{ M}\Omega$.

The following figure shows the circuit for the error detector.

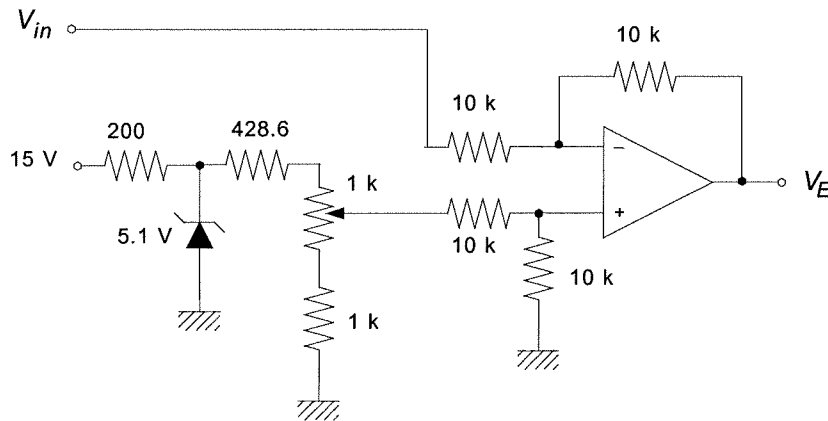

CHAPTER 11

11.1

Such an alarm will simply use a comparator. The comparator trigger voltage will be,

$$V_T = (2.2 \text{ mV/N})(1050 \text{ N}) = 2.31 \text{ V}$$

This voltage is obtained from a divider off of the five volt supply,

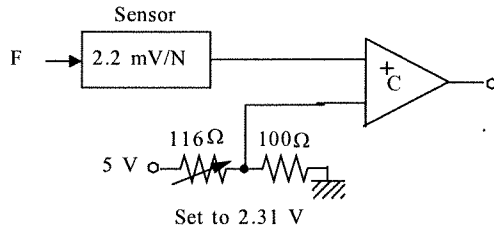

11.2

The Type J TC with a 0 °C reference will produce voltages of, $V_{100} = 5.27 \text{ mV}$ and $V_{150} = 8.00 \text{ mV}$. These voltages are too small for effective use with comparators, or at least there would be more noise susceptibility. Therefore we will amplify the TC output. A gain of 100 will provide voltages near one volt. We use a differential amplifier so that noise problems can be further reduced. The two comparator trigger voltages will be 0.527 V and 0.800 V respectively. These are provided from dividers.

Note the the iron wire of the TC must be connected to the non-inverting side of the differential amplifier input.

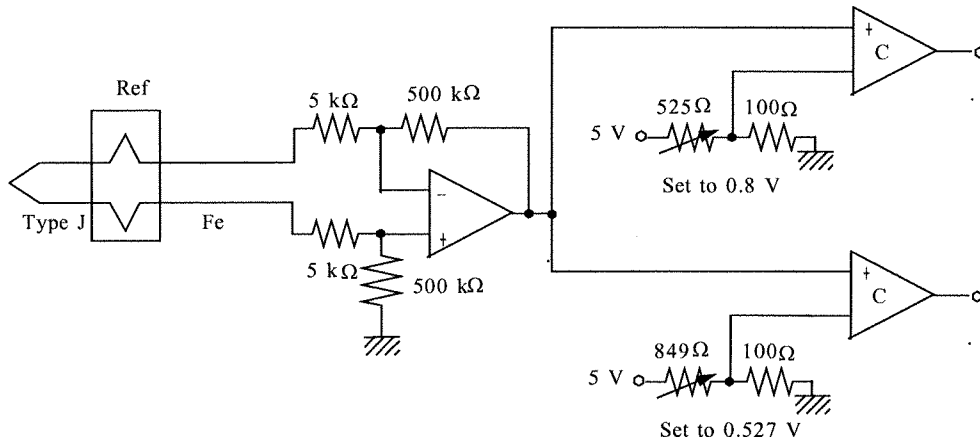

11.3

A two position digital controller can be implemented using two comparators and a D flip/flop as shown in Figure 11.1. In this case we want the clock comparator to go high at 500 N, or at a voltage of,

$$V_H = (2.2 \text{ mV/N})(500 \text{ N}) = 1.1 \text{ volts.}$$

The clear comparator should go low when the input drops below the voltage of 425 N, or,

$$V_L = (2.2 \text{ mV/N})(425 \text{ N}) = 0.953 \text{ volts.}$$

These voltages are provided by dividers. The controller is shown in the following schematic

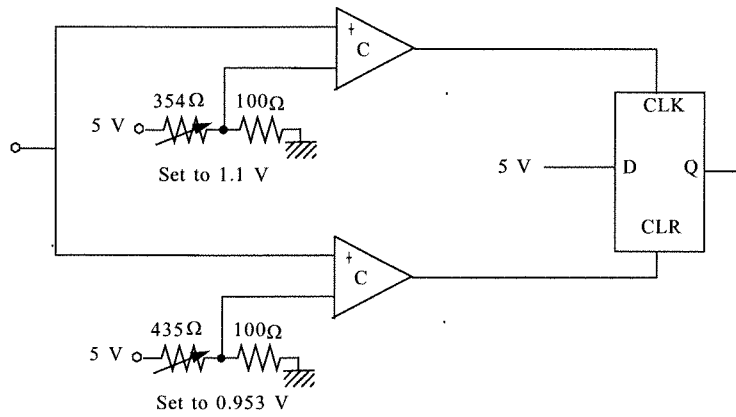

11.4

There are two conditions which could cause an alarm,

(a) S low and L high and R high: $\bar{S} \cdot L \cdot R$

(b) S high and L low: $S \cdot \bar{L}$

Thus the combination is,

$$A = \bar{S} \cdot L \cdot R + S \cdot \bar{L}$$

11.5

We can simply construct the equation using AND and OR gates along with inverters. The solution is,

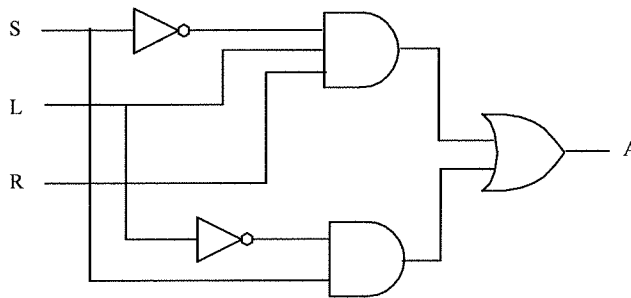

11.6

Let us simply OR all the conditions which can cause VIN and VOUT to go high (open) and then simplify. Thus, examination of the table shows that VIN goes high under the conditions,

$$VIN = \bar{P} \cdot \bar{T} \cdot \bar{L} + P \cdot \bar{T} \cdot \bar{L} = (\bar{P} + P) \cdot \bar{T} \cdot \bar{L} = \bar{T} \cdot \bar{L}$$

VOUT goes high under the conditions,

$$VOUT = P \cdot T \cdot L + \bar{P} \cdot T \cdot L + P \cdot \bar{T} \cdot \bar{L} = (P + \bar{P}) \cdot T \cdot L + P \cdot \bar{T} \cdot \bar{L}$$

$$VOUT = T \cdot L + P \cdot \bar{T} \cdot \bar{L}$$

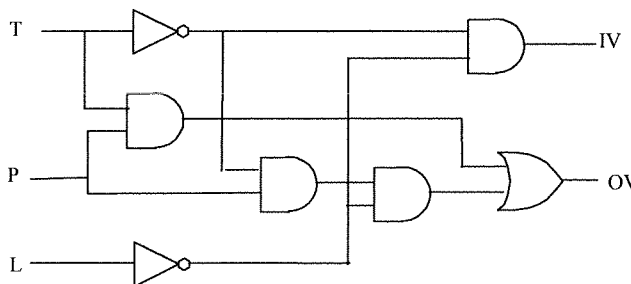

11.7 Well the total number of samples per second is,
 $(40 \text{ variables})(100 \text{ samples/sec per variable}) = 4000 \text{ samples/sec}$
 This means that there will be a time between any two samples of $1/4000$ seconds, or,
 $t_s = 0.00025 \text{ seconds} = 250 \mu\text{s}$

11.8
 The access of one channel requires a time,
 $t_1 = (14)(5.3 \mu\text{s}) + 2.3 \mu\text{s} + 34 \mu\text{s} = 110.5 \mu\text{s}$
 Since there are 100 channels the time before return to the same channel is,
 $T = 100t_1 = (100)(110.5 \mu\text{s}) = 11.05 \text{ ms}$
 A time of 11.05 ms/sample is a sampling rate of,
 $f_s = 1/T = 1/11.05 \text{ ms} = 90.5 \text{ samples/second}$

11.9
 The system has four outputs to the computer: feed rate, preheater setpoint, oven setpoint and cooler setpoint. There are also four inputs to the computer: conveyor speed, T_1 , T_2 and T_3 . A four channel analog multiplexer will be used to input data through a single ADC. Four DAC's will be used for the outputs. The following block diagram shows the essential features of the system.

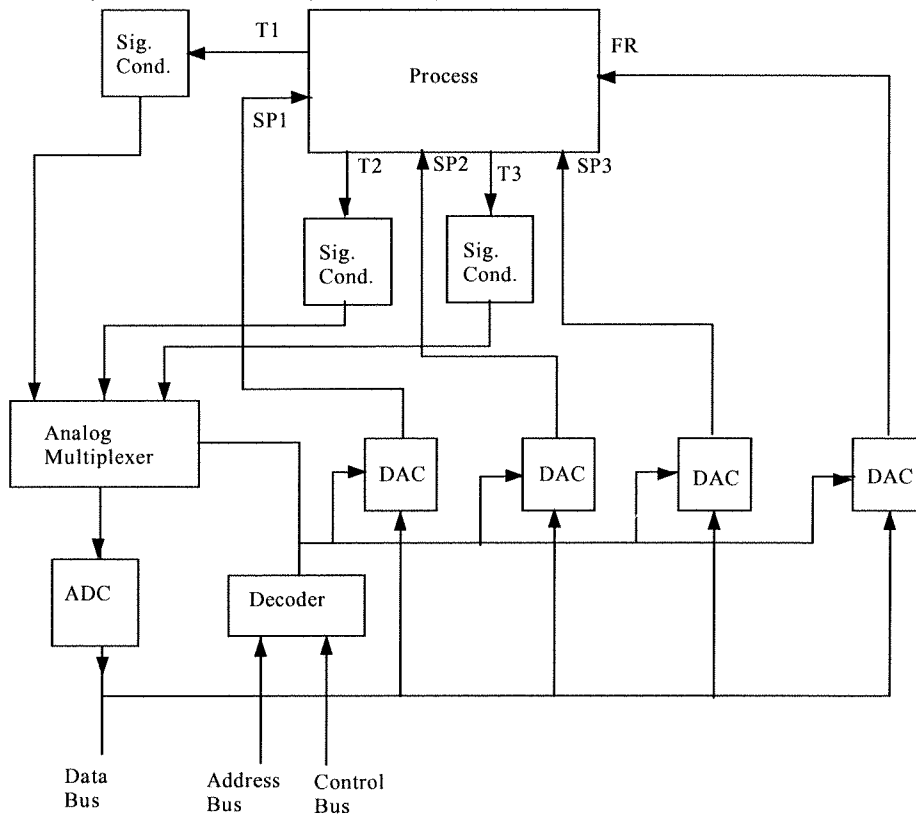

11.10
 A loop will be used which modifies each setpoint as required and then waits for the system to adopt the new values before making another change. The changes are in increments of 1.0% of motor speed setpoint to a total of 5%. This requires a total of 5 increments. It is assumed that the cooler setpoint is being decreased by 4.4%. A single step requires the following delta changes of each variable:

$$\begin{aligned} \text{DSPM} &\Rightarrow 0.050 \cdot \text{SPM} / 5 = 0.01 \cdot \text{SPM} \\ \text{DSP1} &\Rightarrow 0.039 \cdot \text{SP1} / 5 = 0.0078 \cdot \text{SP1} \\ \text{DSP2} &\Rightarrow 0.072 \cdot \text{SP2} / 5 = 0.0144 \cdot \text{SP2} \\ \text{DSP3} &\Rightarrow 0.044 \cdot \text{SP3} / 5 = 0.0088 \cdot \text{SP3} \end{aligned}$$

A flag will be used to note whether a given variable has achieved its new setpoint after each iteration. The flag bits are set to one as the associated variable reaches the new setpoint. The next increment is not started until all the variables have achieved the new setpoints.

The following flowchart shows the software operations.

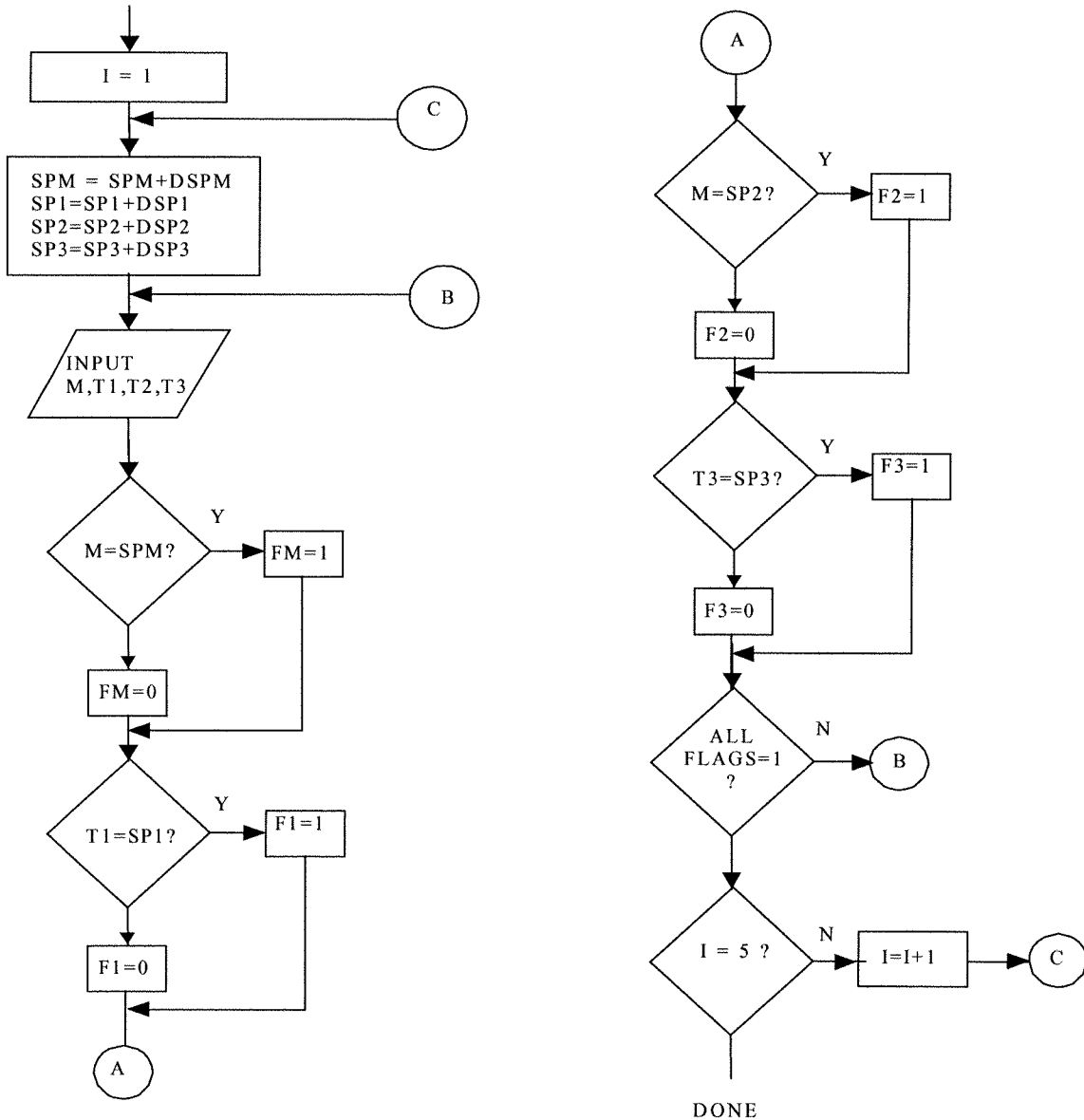

11.11

We assume the temperature reading is taken by the ADC and passed to the software in the form of a base 10 floating point number, NT. This varies from 0 to 63 as the temperature ranges from 60 to 100 °F. The first software equation will find the temperature. They are linearly related so we have,

$$T = mNT + T_0$$

Using the two known pairs we find: $60 = m(0) + T_0$ so that $T_0 = 60$. Next we know that when the temperature is 100 the ADC is at its maximum, 63,

$$100 = m(63) + 60 \text{ so } m = 40/63. \text{ Thus the first equation is}$$

$$T = 40*NT/63 + 60$$

Next we find an equation for the error as a fraction of range, Since the setpoint is 75°F and the range is $(100 - 60) = 40$ °F we have

$$E = (75 - T)/40$$

Since we have expressed the error as the fraction of range the proportional gain can be used directly. Thus the controller equation is,

$$P = 8 * E + 0.5$$

Where the 50% zero error value becomes 0.5 when expressed as a fraction of range.

Finally since the output really only varies from 0 to 63 (6-bit DAC) we form the output by multiplication,

$$POUT = P * 63$$

The resolution in temperature is of course the range of 40oF spread out of $2^6 = 63$ states,
 $\Delta T = 40^\circ F / 63 = 0.625^\circ F$

11.12

To solve this we use rectangular integration. The appropriate equations are as follows.

The percent of range error is:

$$e_p = 100(75 - p)/(100 - 25) = (75 - p)/0.75 \% \text{ The controller equation is,}$$

$$p_i(t) = K_i \int e_p dt \text{ assuming } p_i(0) = 0$$

The rectangular approximation gives,

$$p_i(t) \approx K_i \Delta t \sum(e_{pi})$$

where $e_{pi} = (75 - p_i)/0.75$ are the errors for samples taken at Δt second periods.

$$p_i(0.8) = 0.1225 \sum(75 - p_i)/0.75 = 0.1633 \sum(75 - p_i)$$

Since there are $0.8/0.05 = 16$ samples we can write, $p_i(0.8) = 195.96 - 0.1633 \sum p_i$

Now all we have to do is add all the pressure samples from 0 to 0.8 s in 0.05 s intervals. (Actually to 0.75 s since the sample at 0.8 s would be used for the next rectangular area). From Figure 11.15 we find this sum to be approximately,

$$\begin{aligned} \sum p_i &= 50+56+82+111+125+62+46+78+54+55+90+110+96+60+50+62 \\ &= 1187 \end{aligned}$$

$$p_i(0.8) = 195.96 - 0.1633(1187) = 1.76$$

11.13

The appropriate gains are:

$$\text{Proportional, } K_p = 100/60 = 1.67 \%/\%$$

$$\text{Integral, } K_i = 0.833 \%/(\% \cdot \text{min})$$

$$\text{Derivative, } K_D = 0.05 \%/(\% / \text{min})$$

For error samples, e_{pi} , the control equations (with $\Delta T = 0.8$ min) are,

$$\text{Proportional term : } K_p e_{pi} = 1.67 e_{pi}$$

$$\text{Integral term: } K_p K_i \Delta t e_{pi} = 1.11 e_{pi}$$

$$\text{Derivative term: } K_p K_D (e_{pi} - e_{pi-1}) / \Delta t \text{ or } 0.1(e_{pi} - e_{pi-1})$$

The flowchart for this process is:

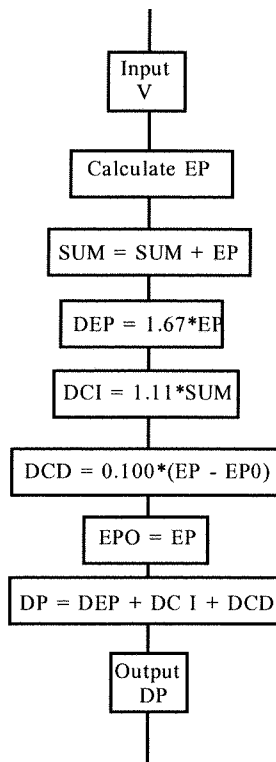

11.14

Let us develop the control equations and from them the flowchart. The input will be a number from 0 to 255 (00 to FFH). This must first be converted to voltage by the relation,

$$V = (N/256) * V_{ref} = 10 * N / 256$$

where N is the input. The temperature can be found by solving the given voltage equation,

$$T = 100 + 10(V - 5) = 10V + 50 \text{ in } ^\circ\text{C}$$

The percent of range error is now found as,

$$e_p = 100 \frac{(100 - T)}{(150 - 50)} = 100 - T \text{ in } \%$$

A 70% PB means a proportional gain of $K_p = 100/70 = 1.43 \text{ \%/\%}$

$$p_p = K_p e_{pi} = 1.43 e_{pi}$$

A 1.5 %/(%-min) integral gain with samples every 0.5 min provides an integral term of,

$$p_i = K_p K_i \Delta t e_{pi} = 1.07 e_{pi}$$

The net output is then, $p = p_p + p_i$. This provides the output as a percent of the output range.

The output range is from 0 to FFH or 255 so than the actual output is,

$$p_{out} = p * 255 / 100 = 2.55 * p$$

The following flowchart describes this control process.

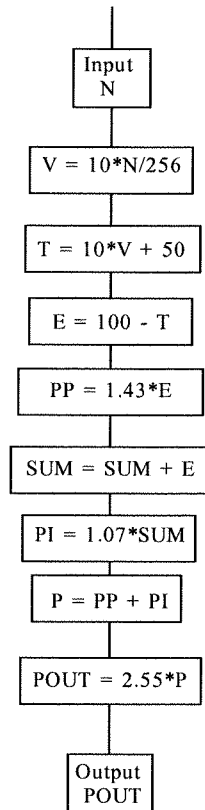

11.15

In this problem the input number N varies from 00 to FFH or from 0 to 255₁₀ and the reference is given as 5 volts. Thus we find the voltage from,

$$V = (N/256) * V_{ref} = 5 * N / 256$$

The actual position is found from the given equation relating voltage and temperature. First we solve for the exponential term,

$$e^{0.02L} = 2V + 1$$

then take the natural logarithm of both sides,

$$\ln(e^{0.02L}) = \ln(2V + 1)$$

or

$$0.02L = \ln(2V + 1)$$

finally,

$$L = 50 \ln(2V + 1)$$

We can determine the error as percent of range by noting that the maximum measurement range is determined by the range of analog to digital conversion, thus

for $V = 0$: $L = 0$

for $V = 5$: $L = 119.89 \approx 120$ mm

Therefore the error is,

$$e_p = 100(50 - L) / (120 - 0) = 0.833(50 - L) \text{ in } \%$$

The proportional gain is given as $K_p = 3.7$ so,

$$p_p = K_p e_{pi} = 3.7 e_{pi}$$

The integral term is,

$$p_i = K_p K_I \Delta t e_{pi}$$

where $K_I = 0.9\% / (\% \cdot \text{min})$, $\Delta t = 2 \text{ s} = 2/60 \text{ min} = 0.0333 \text{ min}$

so,

$$p_i = 0.111 \sum e_{pi}$$

The output in % is $p = p_p + p_i$ but this must be converted to the range of 0 to 255,

$$p_{out} = 2.55p$$

In summary the control equations will be,

$$DV = 5 * DIN / 256$$

; determines voltage from input

$$DT = 50 * \text{LOG}(2 * DV + 1)$$

; determines temperature

$$DE = 0.8333 * (50 - DT)$$

; error as percent of

DP = 3.7*E	;range
SUM = SUM + DE	;proportional term
DI = 0.111*SUM	;rectangular integration
DPI = DP + DI	;integral term
DOUT = 2.55*DPI	;output as percent
	;output

11.16

Adding derivative action to Problem 11.19 means that the output will now have a term,

$$p_D = K_P K_D (e_{pi} - e_{pi-1}) / \Delta t$$

where now $K_D = 0.1 \text{ \%}/(\text{\%/s})$, thus,

$$p_D = 0.185(e_{pi} - e_{pi-1})$$

This term would be added to the output and, of course with each new sample the values of e_{pi} and e_{pi-1} would have to be updated.

To use the alternate, iterative control equations we have,

$$p_i = p_{i-1} + A * e_{pi} - B * e_{pi-1} + C * e_{pi-2}$$

where: $A = K_P + K_P K_D \Delta t + K_P K_D / \Delta t = 3.7 + 0.111 + 0.185 = 3.996$

$$B = K_P + 2K_P K_D / \Delta t = 3.7 + 2(0.185) = 4.07$$

$$C = K_P K_D \Delta t = 0.185$$

For the control equations let us make the following identifications,

PI = new control output as percent

PI0 = previous control output as percent

DE = present error

DE1 = first previous error (i-1)

DE2 = second previous error (i-2)

Then we have,

$$DV = 5 * DIN / 256$$

$$DT = 50 * \text{LOG}(2 * DV + 1)$$

$$DE = 0.833 * (50 - DT)$$

$$PI = 3.996 * DE - 4.07 * DE1 + 0.185 * DE2$$

$$POUT = 2.55 * PI$$

$$DE1 = DE$$

$$DE2 = DE1$$

Supplementary Problems

S11.1

(a) To get the user temperature setting into the computer we need signal conditioning so that a variation of 0 to 1000 Ω becomes 0 to 4.980 volts (ADC ref - LSB voltage). To maintain linearity let's put the 1 k Ω variable resistor in the feedback of an op amp inverting amplifier. We will make the input a fixed -5.1 volt source from a zener regulator. Then the output voltage will be,

$$V_{set} = -(R_2 / R_1) (-5.1 \text{ V}) \text{ where } R_2 \text{ is the variable resistor. To find } R_1 \text{ we need,}$$

$$4.980 = (1000)(5.1) / R_1 \text{ or } R_1 = 5100 / 4.980 = 1024 \Omega.$$

For the thermistor we have from the graph that at 30°C the resistance is 5 k Ω and at 50°C the resistance is 550 Ω . We need to convert this to 0 to 4.980 volts as above. We are going to ignore the non-linearity. It can be accounted for in the software. Using a linear signal conditioning we have,

$$V_T = mR_T + V_0$$

so,

$$0 = 5000m + V_0$$

$$4.98 = 550m + V_0$$

These are easily solved to find $m = -4.98/4450$ and $V_0 = 5000(4.98)/4450$. The signal conditioning equation can thus be written,

$$V_T = -\frac{R_T}{4450} (4.98) + \frac{5000}{4450} (4.98)$$

The first term looks like an inverting amplifier with the sensor in the feedback. then a summing amplifier is used to combine the output with a fixed bias. Suppose we use a fixed -5.1 volts from a zener regulator as input to the inverting amplifier. Then the equation becomes,

$$V_T = -\frac{R_T}{4557}(5.1) + 5.596$$

The circuit below shows these signal conditioning circuits. In both cases the outputs are ready for input to the ADC.

(b) The required digital connections are determined as follows:

1. Since DAC output is via Port 302 that decoder output will become active (low).

Therefore it is connected to the DAC write line. When the computer writes to Port 302 it places the data on the data bus and taking the DAC write line low causes it to latch the data from the bus.

2. In a similar fashion when the computer reads from Port 301 the decoder 301 line goes low so this is used to enable the read line of the ADC. The ADC then places its output on the data bus so the computer can capture the data.

3. Port 300 is used for control input and output. This is done by writing to the latch for computer output commands and reading from the latch to determine external status. Thus we write successive high-low-high to b0 in order to issue a start-convert to the ADC. We write either a low or high to b2 to select either channel 0 or 1 for input. The end-of-convert is interrogated by reading b7 from the same latch.

The following circuit shows the resulting digital connections.

(c) The flowchart shown below simple issues the commands and inputs described above.

(d) The control equations are implemented by first converting ADC inputs into their actual value equivalents. That is, the temperature sensor input, which varies from 0 to 255 is converted into the value of resistance which caused the input and similarly with the temperature setpoint.

T: $TSP = 30 + 20NT/255$ where NT is the ADC input

The sensor is nonlinear so a lookup table with interpolation is then used to determine the actual temperature. NR is the ADC input from the sensor:

NR	0	32	64	96	128	160	192	224	255
T	30	31	32	33.5	35.2	37.2	40	43.8	50

Interpolation: $T = TL + (TH - TL)*(VT - VL)/32$

Now a temperature error is calculated and converted to fraction of range so that the gains can be used directly. Since the integral gain is given in min^{-1} it is converted to s^{-1}

Error: $E = (TSP - T)/20$ (fraction of range)

$KP = 0.025$ and $KI = 0.08/60 = 0.00133$. For the control equations we use the interative form as given by Equation (11.22) but with $KD = 0$ (no derivative action), and scaled for an output of 0 to 255,

$$P_i = P_{i-1} + A*DE_i - B*DE_{i-1}$$

$$A = KP + KP*KP*DT = 0.025 + 0.025(0.00133) = 0.025033$$

$$B = KP = 0.025$$

But the valve output is the control equation output times 255, $VALVE = 255*P_i$.

So we get,

$$VALVE = VALVE0 + 8.9*E - 6.7*E1$$

$$VALVE0 = VALVE$$

$$E1 = E$$

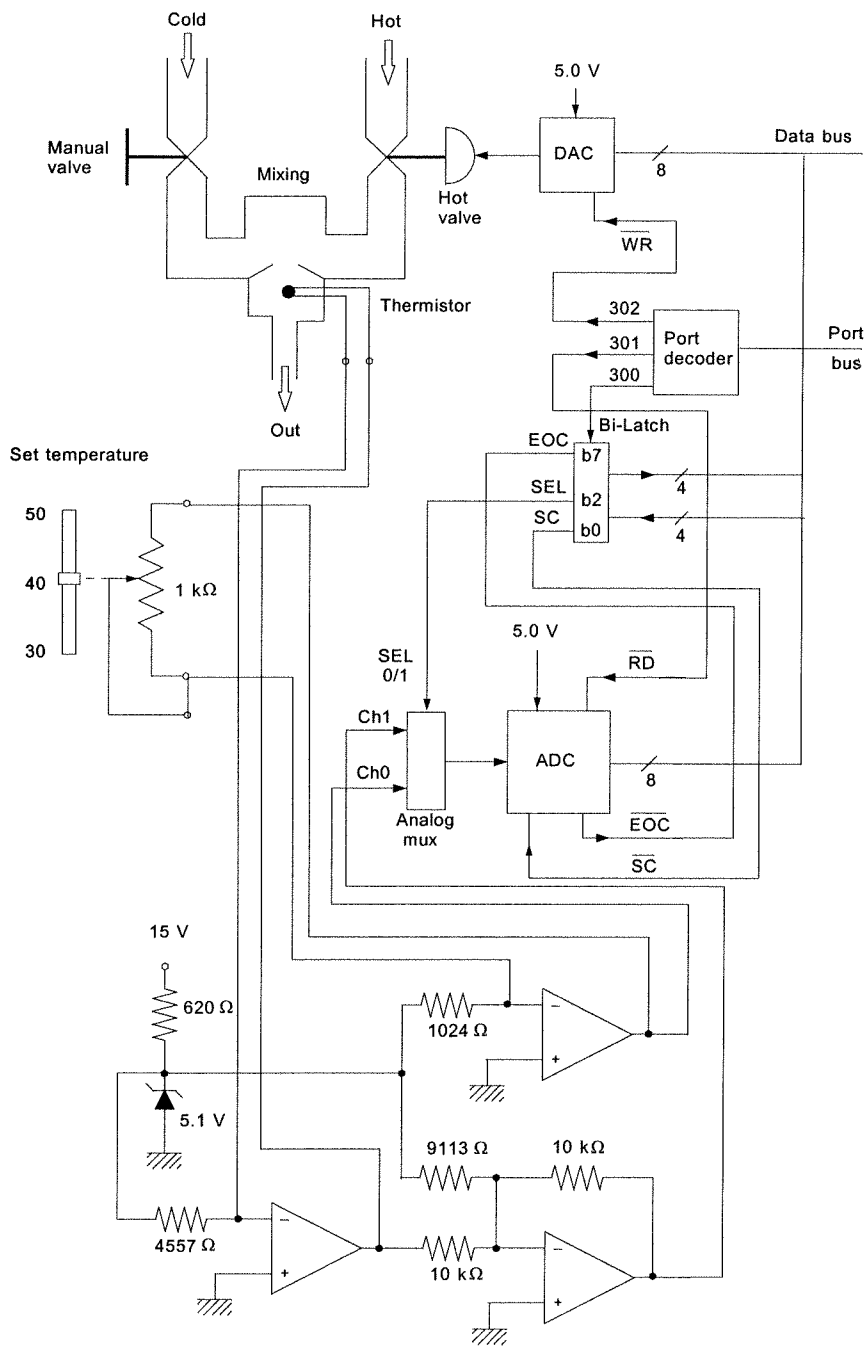

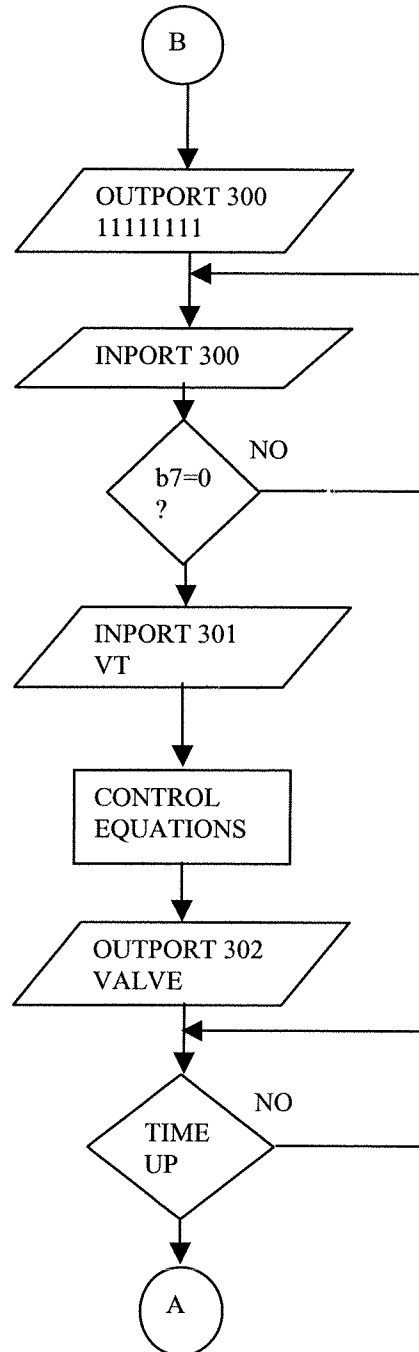
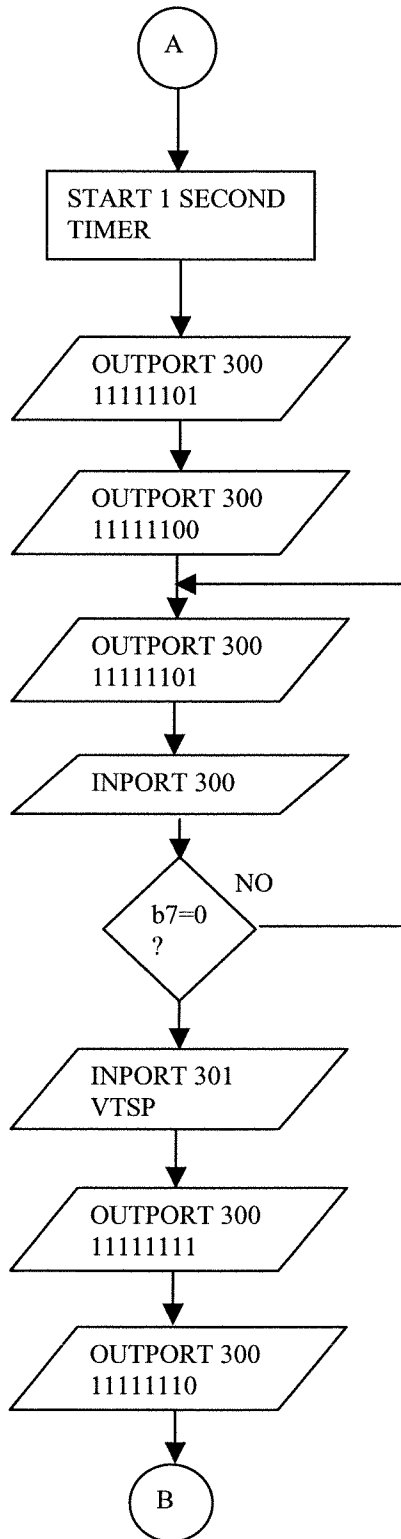

CHAPTER 12

12.1 The block diagram of this control system requires two measurement and signal conditioning systems. Furthermore it is necessary to include an element which will produce an output scaled by the ratio of pressure to temperature to be 0.39. This can be done by using a signal conditioning system which outputs some fraction of the temperature signal and subtracts this from the pressure signal. The fraction is not necessarily 0.39 because the signals are scaled versions of the actual variables.

In block diagram form this might appear as:

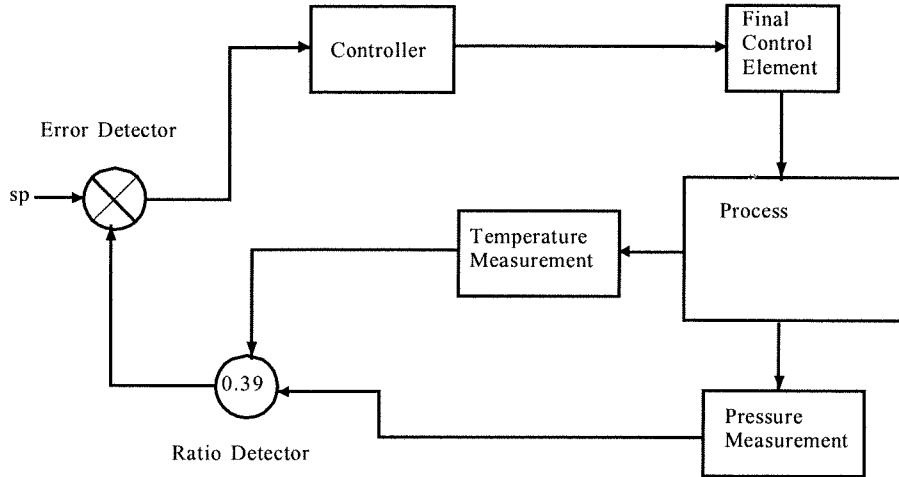

(b) The controller, final control element and sensors are standard elements. The two signal conditioning systems provide signals which can be expressed in terms of pressure in N/m^2 and temperature in K . The question here is what to do about the error detector and setpoint. To see this let us assume the signal conditioning systems output currents (i.e., 4 to 20 mA) according to the relations,

$$I_p = K_p p + I_{p0}$$

where I_p is the current from the pressure sensor K_p is whatever constant converts pressure in N/m^2 into mA

I_{p0} is the current which would flow for zero pressure (this may be only mathematically significant since zero pressure may never occur), and

$$I_T = K_T T + I_{T0}$$

where I_T is the current from the temperature sensor, K_T is the appropriate constant for converting temperature in K into mA, I_{T0} is the current for zero temperature

Now, the ratio detector is to output a signal, $s = p - 0.39T$. The current ratio detector will find the difference between two currents which must be scaled by some factor, not necessarily 0.39,

$$\begin{aligned} I_{ratio} &= I_p - KI_T \\ &= K_p p + I_{p0} - KK_T T - KI_{T0} \\ I_{ratio} &= K_p [p - K(K_T/K_p)] + (I_{p0} - KI_{T0}) \end{aligned}$$

Now, when the ratio is correct we know $p - 0.39T = 0$, thus we must have,

$$K(K_T/K_p) = 0.39 \quad \text{or} \quad K = 0.39(K_p/K_T)$$

also, when the ratio is correct (zero error) the current will not be zero so this tells us the setpoint on the

controller error detector must be,

$$I_{sp} = I_{p0} - KI_{T0}$$

12.2 Since we have sensors and signal conditioning with known transfer functions it is possible to express the pressure and temperature signals in terms of voltage,

$$V_{p0} = (11.5 \text{ mV}/(N/m^2))p$$

and $V_{T0} = (2.75 \text{ mV}/K)T$

These are converted to scales of $1 \text{ mV}/(N/m^2)$ and $1 \text{ mV}/K$ respectively by attenuators with gains of,

$$G_p = 1/11.5 = 0.087 \quad \text{so} \quad V_p = 0.087V_{p0} = p \text{ (in mV)}$$

and $G_T = 1/2.75 = 0.364 \quad \text{so} \quad V_T = 0.364V_{T0} = T \text{ (in mV)}$

Now this is followed by a summing amplifier which forms the difference between the attenuator outputs but with the temperature signal reduced by 0.39,
 $V_E = V_p - 0.39V_T$

The following circuit provides this specification.

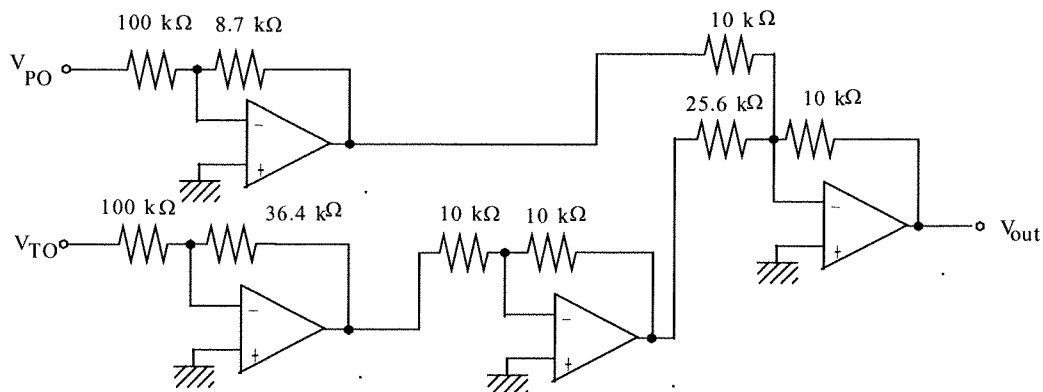

12.3

The following block diagram shows a cascade control system as required.

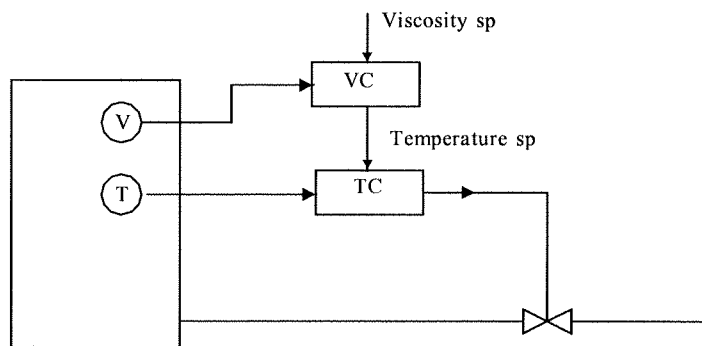

12.4

The block diagram simply shows the required signal conditioning and data input and output systems. The following system shows one possible arrangement.

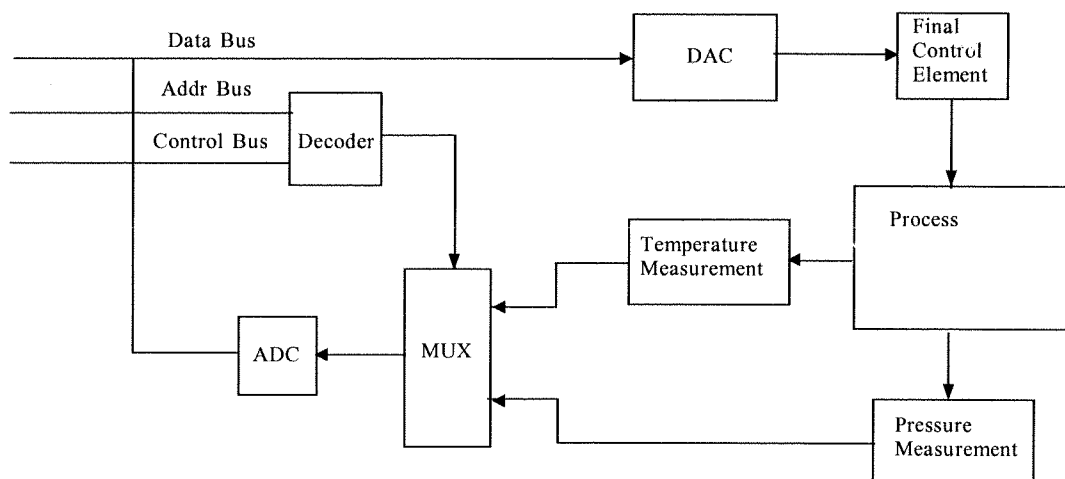

For the software it is assumed that routines are written which convert the incoming pressure and temperature signals into forms scaled directly in terms of the transducer voltages. Then it is simply necessary to divide by 0.0115 and 0.00275 respectively to obtain pressure and temperature directly. These are then used to determine an error which is proportional to the difference between the pressure and 0.39 times the temperature.

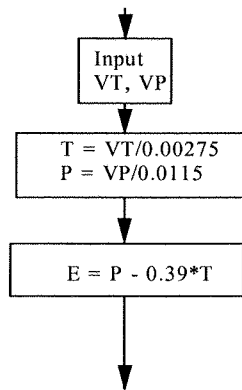

12.5 A typical hardware configuration for the cascade control system is shown below. Note that there is only one output to the process since the viscosity loop only outputs the setpoint of the inner temperature loop.

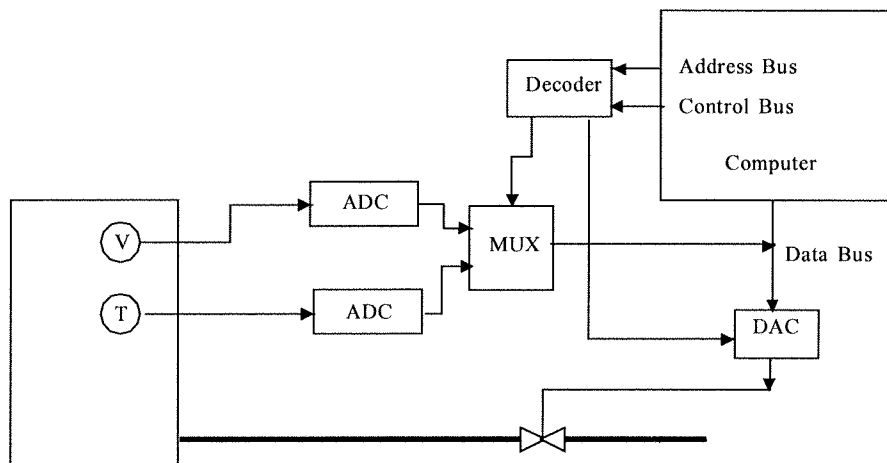

The software part of the DDC cascade control system requires two inputs and one output. A typical flowchart of the required operations is as follows

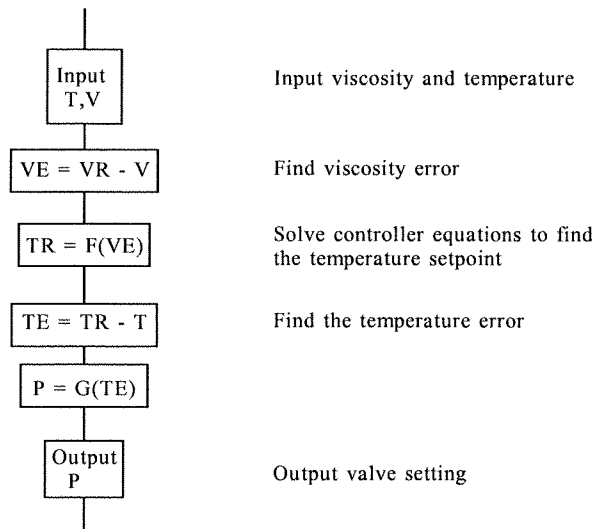

12.6

Diode CR1 passes positive voltages to the upper (R_3) input of the summing integrator and diode CR2 passes negative voltages to the inverting amplifier. The inverter then converts this to a positive voltage and passes it to the lower (R_4) input of the summing integrator. The output can thus be written,

$$V_{out} = -\frac{1}{R_3(2 \mu F)} \int |V_E| dt - \frac{1}{R_4(2 \mu F)} \int |V_E| dt$$

For the output to be in V-s we need the gains to be unity. So, $R_3 = R_4$ and $R_3 C = 1$, thus,

$$R_3 = 1 \text{ s} / 2 \mu\text{F} = 500 \text{ k}\Omega = R_4$$

The output is now,

$$V_{out} = - \int |V_E| dt$$

Of course the forward biased voltage drop of the diodes will reduce the accuracy of this circuit. An improved circuit would use op amp circuits to overcome this error.

12.7

The composite transfer function is found as a product of the gains and a sum of the phases.

At 10 rad/s:

$$G = (20)(1.4)(0.05)(3.2) = 4.48$$

$$\phi = 0^\circ - 90^\circ + 90^\circ + 85^\circ = 85^\circ$$

12.8 The transient response test has $\Delta P = 7.5\%$ and results in the following reaction.

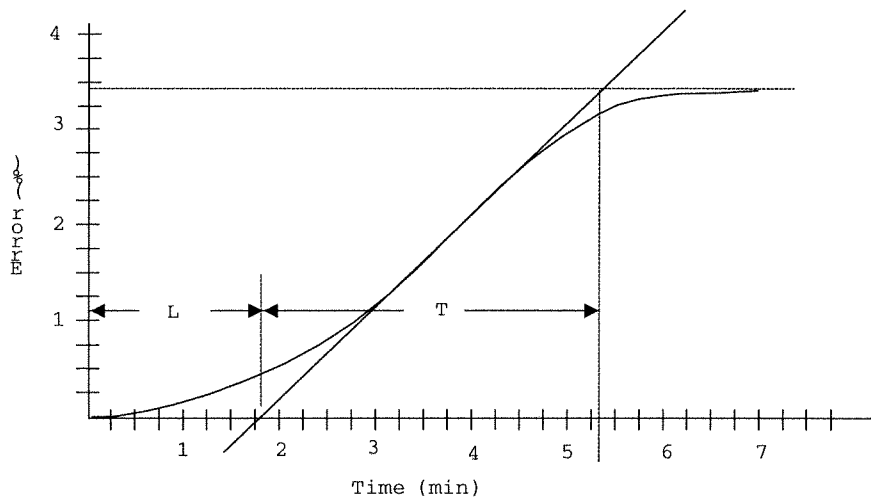

The inflection point tangent has been drawn. This tangent line intersects the zero line at approximately, $L = 1.75$ min and the process reaction time is shown to be $T = 3.5$ min.

(a) The standard PI gains are found from, reaction rate,

$$N = \Delta C_p / T = 3.4\% / 3.5 \text{ min} = 0.97 \text{ \%}/\text{min}$$

$$K_p = \Delta P / NL = (7.5\%) / (0.97)(1.75) = 3.97 \text{ \%}/\%$$

$$T_i = 3.33L = 3.33(1.75) = 5.83 \text{ min} \quad [K_i = 0.171 \text{ \%}/(\text{\%}\cdot\text{min})]$$

(b) The PID quarter amplitude gains are,

$$\log \text{ ratio}, R = NL / \Delta C_p = (0.97)(1.75) / 3.4 = 0.5$$

$$K_p = \Delta P [1.33 + R/4] / NL = 7.5 [1.33 + 0.5/4] / (0.97)(1.75)$$

$$K_p = 6.43 \text{ \%}/\%$$

$$T_i = (32 + 6R)L / (13 + 8R) = [32 + 6(.5)](1.75) / [13 + 8(.5)]$$

$$T_i = 3.6 \text{ min} \quad [K_i = 0.278 \text{ \%}/(\text{\%}\cdot\text{min})]$$

$$T_D = 4L / (11 + 2R) = 4(1.75) / [11 + 2(.5)]$$

$$T_D = 0.58 \text{ min} \quad [K_D = 0.58 \text{ \%}/(\text{\%}/\text{min})]$$

12.9

$K_c = 4.2 \text{ \%}/\%$ and $T_c = 2.21$ min.

(a) For Proportional control, $K_p = 0.5K_c = (0.5)(4.2)$

$$K_p = 2.1 \text{ \%}/\%$$

(b) For PI control,

$$K_p = 0.45K_c = (0.45)(4.2) = 1.89 \text{ \%}/\%$$

$$T_i = T_c / 1.2 = 2.21 \text{ min} / 1.2 = 1.84 \text{ min} \quad [K_i = 0.54 \text{ \%}/(\text{\%}\cdot\text{min})]$$

(c) For PID control,

$$K_p = 0.6K_c = (0.6)(4.2) = 2.52 \text{ \%}/\%$$

$$T_i = T_c / 2 = 2.21 \text{ min} / 2 = 1.105 \text{ min} \quad [K_i = 0.905 \text{ \%}/(\text{\%}\cdot\text{min})]$$

$$T_D = T_c / 8 = 2.21 \text{ min} / 8 = 0.277 \text{ min} \quad [K_D = 0.277 \text{ \%}/(\text{\%}/\text{min})]$$

12.10

(a) The gain margin will be the amount the gain exceeds unity when the phase is -180° . You can see that a vertical line drawn at the frequency where the phase is -180° intersects the gain curve at about 1.3. Thus not only is there NO gain margin, the system is unstable!

(b) The phase margin will be the difference of the phase from -180° when the gain is unity. But you can see that a vertical line drawn down from the unity gain crossover frequency to the phase curve

intersects the phase curve at about -190° . Thus, not only is there NO phase margin, but the system is unstable!

12.11

An increase of proportional gain will move the gain curve up without changing the phase curve while a decrease of proportional gain will move the gain curve down. In this case we need to move the gain curve down so that a decrease in proportional gain is necessary.

To find the necessary gain reduction you can see on the Bode plot, reproduced below, that the gain at 140° (for a 40° phase margin) is about 3.5. It should be unity (1). This means that the gain of 11.5 must be reduced by a factor of 1 to 3.5, i.e.,

$$K_p = 11.5/3.5 = 3.29$$

The new gain curve has been plotted for this gain reduction. Now satisfaction of the gain margin must be checked to see if further proportional gain reductions are necessary. At a phase of -180° we see that the gain is less than 0.56 (5 dB) so the gain margin is satisfied.

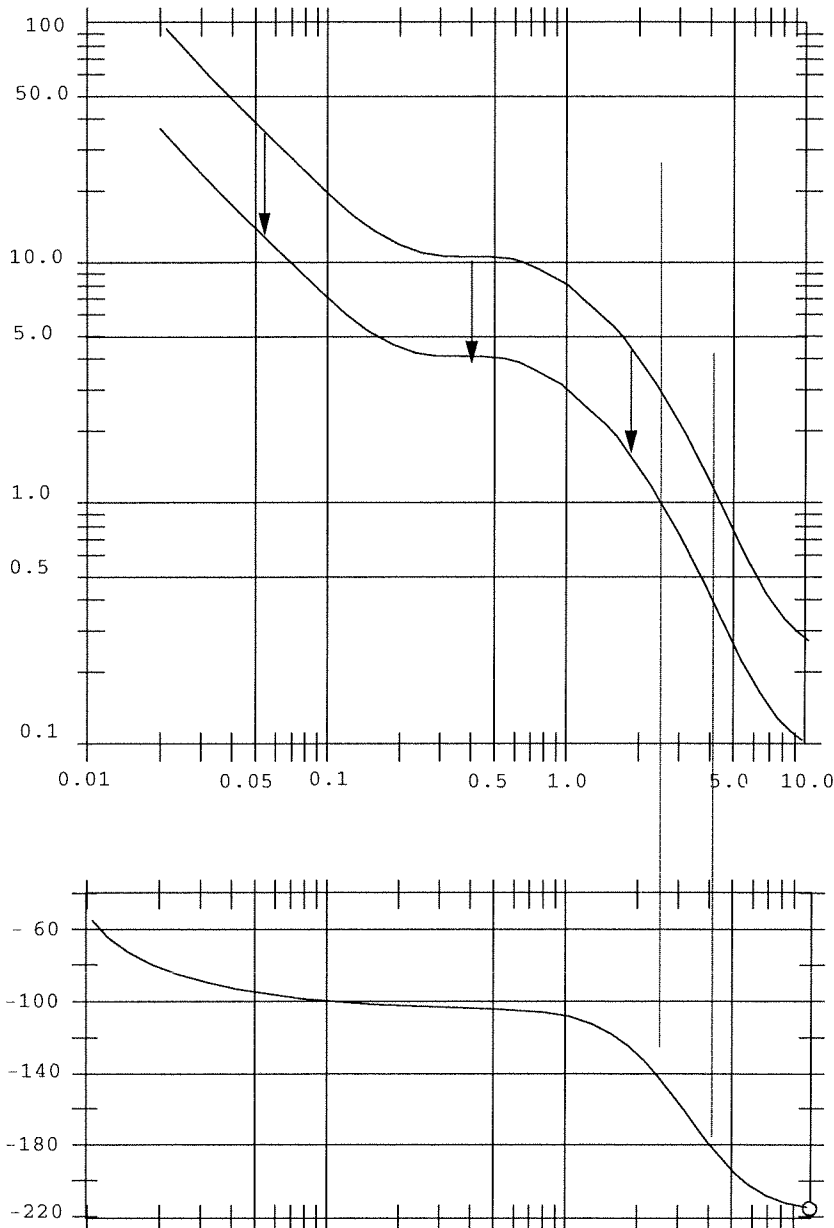

This is the Bode plot for Problems 12.10 and 12.11

12.12

The new gain curve is obtained by multiplying the gains at a each frequency and plotting the resultant product. Thus, for example the point at a frequency of 0.1 rad/s is the product of the proportional term, $K_p = 6$, the integral term, 10, and the derivative term, 1, thus the point to be plotted at a frequency of 0.1 rad/s is,

$$p = (6)(10)(1) = 60$$

If this is repeated at various frequencies and a smooth line drawn joining the points the Bode gain curve following results.

The new phase curve is found by adding the phases of each term at each frequency. Thus, again at 0.1 rad/s, the proportional term phase is 0° , the integral term gain is 90° and the derivative term phase is $+90^\circ$. The resultant new phase is,

$$\phi = 0 - 90 + 90 = 0^\circ$$

The resultant gain and phase curves are shown on the following Bode plot.

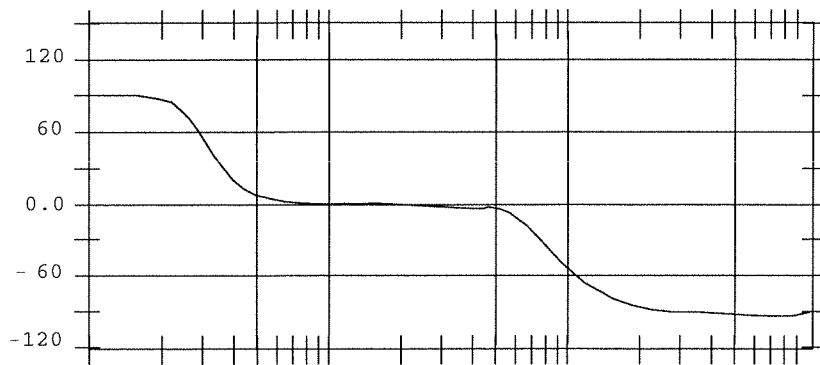
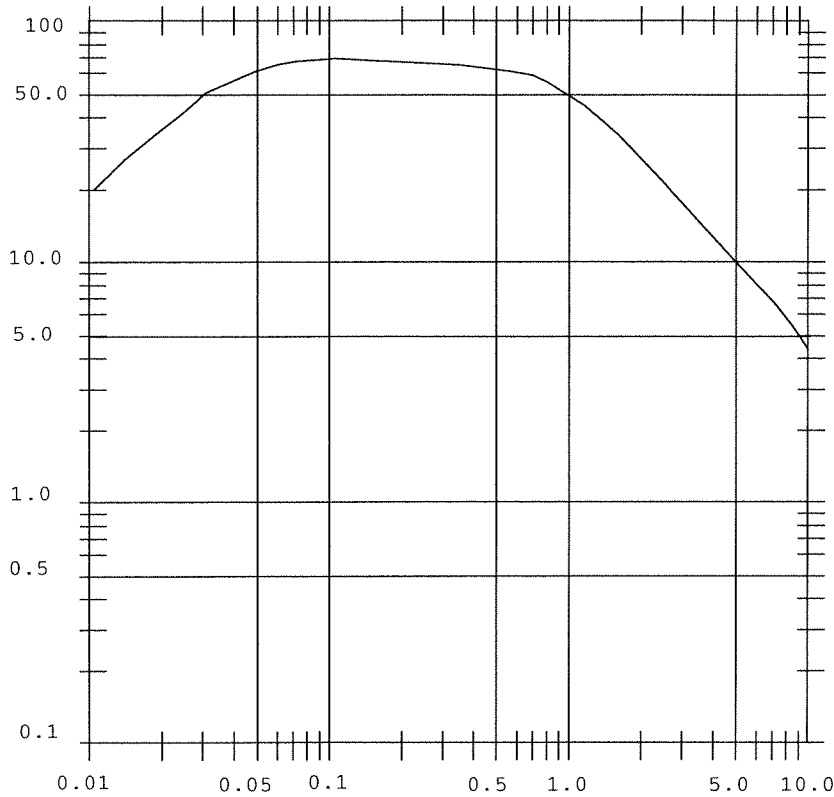

12.13

The composite transfer function is found by constructing curves of gain as the product of each term and phase as the sum of each term, as a function of frequency. In the following table the approximate values of the process, integral term and proportional term are used to form the gain product and phase sum at various frequencies.

ω	GAIN	PHASE
0.01	1008	20
0.02	302	-10
0.05	126	-90
0.1	72	-140
0.2	58	-120
0.5	15	-80
1	5	-80
2	1	-135
5	0.2	-210
10	0.1	-260

The gain and phase are plotted on the following Bode graph.

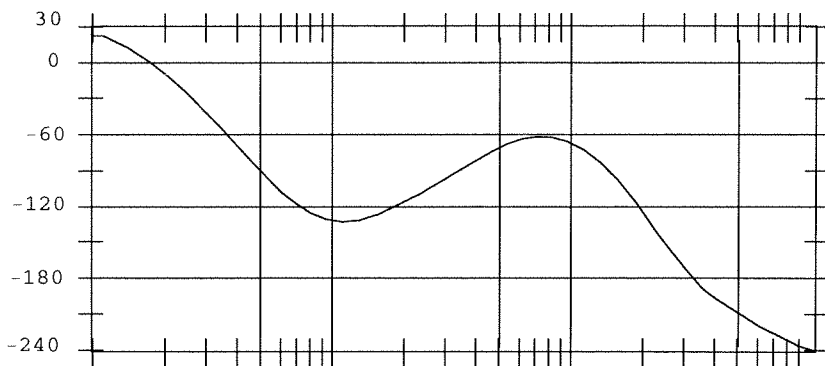
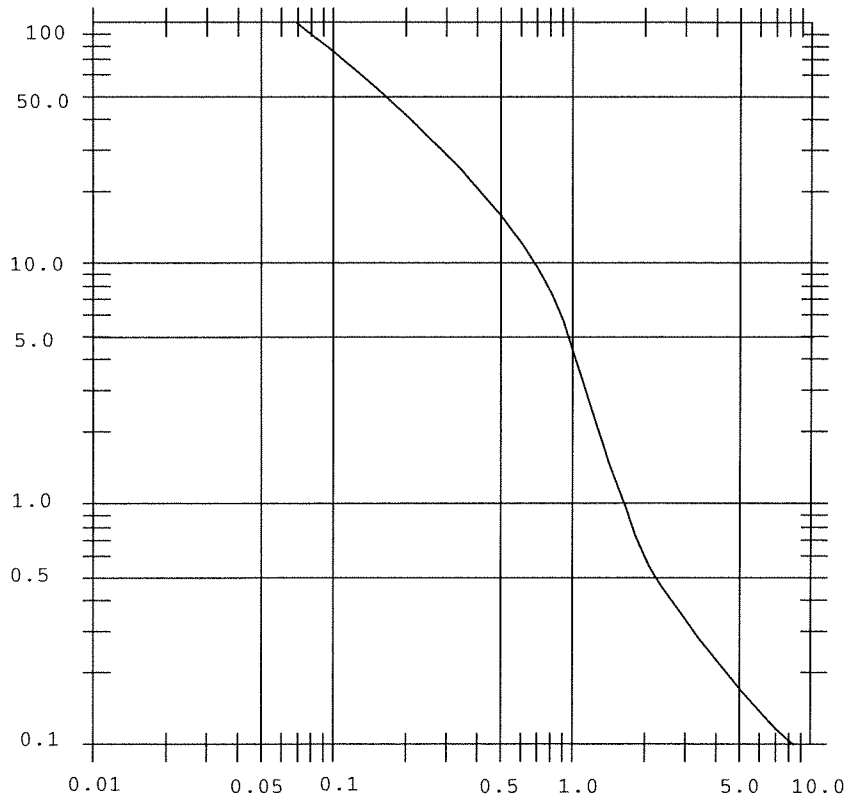

You can see from the graph that at -180° the gain is 0.3 which is a gain margin of,

$$\text{Gain Margin} = 20\log(.3) = 10 \text{ dB}$$

The phase margin is found by noting that the phase at unity gain is approximately -120° for a phase margin of,

$$\text{Phase Margin} = -120 - (-180) = 60^\circ \text{ The system is stable.}$$

12.14

The effect of derivative action will be to lower the gain at low frequencies, raise the gain at higher frequencies and increase the phase by 90° . The additional phase will effectively cancel out the integral term phase shift and leave the phase as it was for the original process, except at low frequencies where the integral term is not effective. Of course it will be necessary to terminate the derivative action at some upper cut-off frequency.

The derivative action contributes a factor of ωK_D to the gain and $+90^\circ$ to the phase. If we take $K_D = 1$ then the new data for plotting is found by multiplying the old gain by ω and adding 90° to the phase. The following table shows the resulting gain and phase data versus frequency.

ω	GAIN	Phase
0.01	10.1	110
0.02	6.0	80
0.05	6.3	- 15
0.1	7.2	- 50
0.2	11.5	- 30
0.5	7.5	10
1.0	5.0	15
2.0	2.0	- 55
5.0	1.0	-120
10.0	0.9	-170

This is plotted on the following Bode Plot.

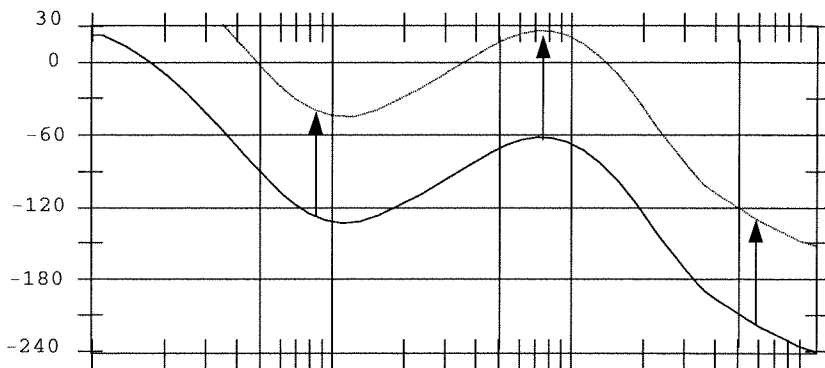
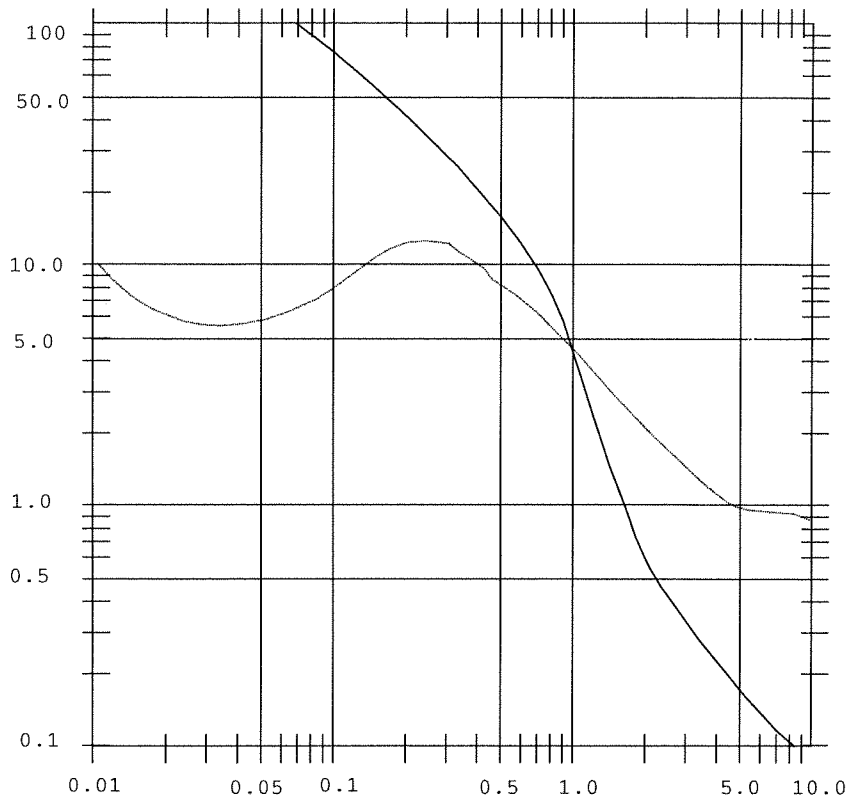

This system will be unstable since the gain curve will increase beyond $\omega = 10$ and eventually rise to unity, while the phase curve will continue to drop. It will be necessary to cut-off the derivative action at some upper frequency limit.

12.15

To drive the system into instability using proportional gain means increasing the gain until the system has unity gain at -180° . From the Bode plot you can see that the gain at -180° is 0.22 for the proportional gain of one. Thus the increase in proportional gain for instability is,

$$0.22K_p = 1 \quad K_p = 1/0.22 = 4.55$$

This means that at a proportional gain of 4.55 the system is marginally stable, i.e., for gains infinitesimally larger the system will be unstable. By the ultimate cycle tuning process the proper proportional gain would be,

$$K_p = 0.5K_c = 2.275$$

This gain provides a gain margin (gain at -180°) of

$$\text{Gain Margin} = (0.22)(2.275) = 0.5$$

which is,

$$= 20\log(0.5) = -6 \text{ dB}$$

You can also see this from the graph. The graph also shows that phase at a unity gain with this new proportional gain is -40° so that the phase margin = 140° .

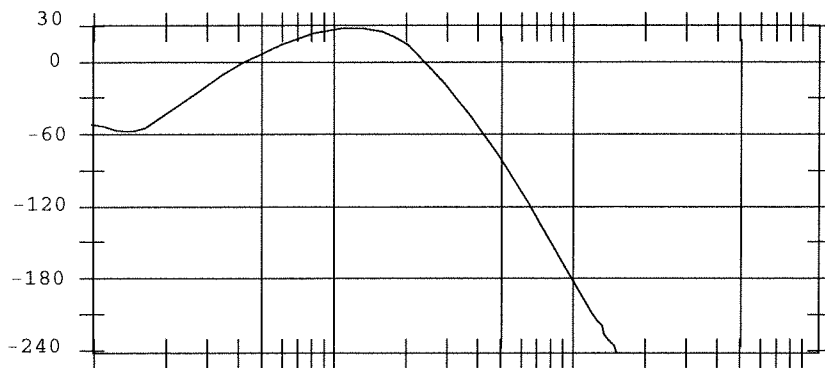
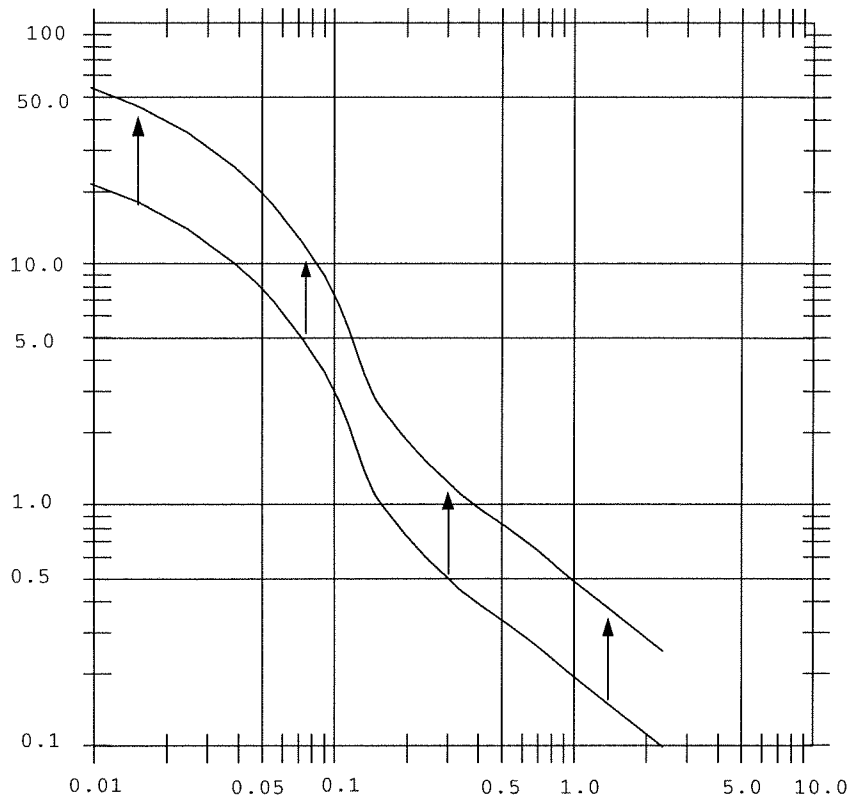

12.16

In order to specify the tuning of this system we need to convert the given information into percents of range. This is because the tuning equations are all expressed in this unitless fashion.

The change in controller output, ΔP , which caused the transient response was from 14 to 16.5 volts out of a 24 volt range, thus,

$$\Delta P = 100(16.5 - 14)/(24) = 10.4\%$$

The temperature was at the setpoint of 220 °C when the test was started and you can see that it settled again at a temperature of 256 °C. The range is given as 140 to 330 °C, so the error expressed as a percent of range is,

$$\Delta C_p = 100(256 - 220)/(330 - 140) = 18.9\%$$

Now the PID mode gains can be found by drawing the inflection point line on the reaction graph as follows:

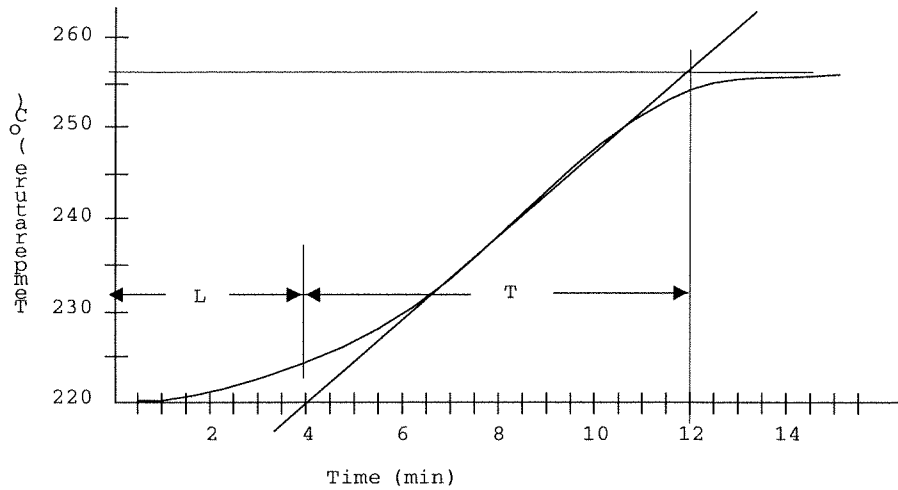

From the inflection point graph we see that $L = 4$ min and $T = 8$ min. Therefore,
 $N = \Delta C_p / T = 18.9 / 8 = 2.3625$

Then,

$$K_p = 1.2 \Delta P / (NL) = (1.2)(10.4) / [(2.3625)(4)] = 1.38 \text{ \%/\%}$$

$$T_i = 2L = 2(4 \text{ min}) = 8 \text{ min} \quad (K_i = 0.125 \text{ \%}/(\text{\%-min}))$$

$$T_D = 0.5L = 0.5(4 \text{ min}) = 2 \text{ min} \quad (\text{\%}/(\text{\%/min}))$$

12.17

This is a plot of actual gain versus frequency rather than gain in dB. Unity gain is 0 dB and a 5 dB gain margin means an actual gain of $20 \log(A) = -5$ which gives $A = 0.56$. From the Bode plot we see that at a phase of 180° the gain is very nearly unity which is greater than 0.56 (5 dB) so the system does not satisfy a 5 dB gain and in fact is marginally unstable.

Since the present proportional gain is 5.0 we must reduce this gain to provide a gain of 0.56 at 180° . We can form an equation,

$$20 \log(5) + K_{\text{sys}} = 1 \text{ at the frequency of } -180^\circ$$

and

$$20 \log(K_{\text{new}}) + K_{\text{sys}} = 0.56$$

Subtracting we have,

$$20 \log(5) - 20 \log(K_{\text{new}}) = 0.44$$

which gives a new proportional gain of

$$K_{\text{new}} = 4.75$$

The phase margin is found by finding the phase angle when the gain of the original curve is about 1.56. After the gain reduction this will be unity gain (0 dB). This occurs at about 1.1 rad/s. At this frequency the phase shift is about -160° so the phase margin is 20° .

Supplementary Problems

S12.1

The inflection point and times have been identified for the response curve as follows. The value of ΔC_p is found by converting the resistance to power. We find:

$$1550 \Omega \text{ is } 44 \text{ mW/cm}^2$$

$$1240 \Omega \text{ is } 60 \text{ mW/cm}^2$$

So the total change is 16 mW/cm^2 . Since the range is 60 mW/cm^2 this is a 26.7% change. On the other hand ΔP changes by $100(1.5 \text{ V}) / 10 \text{ V} = 15\%$.

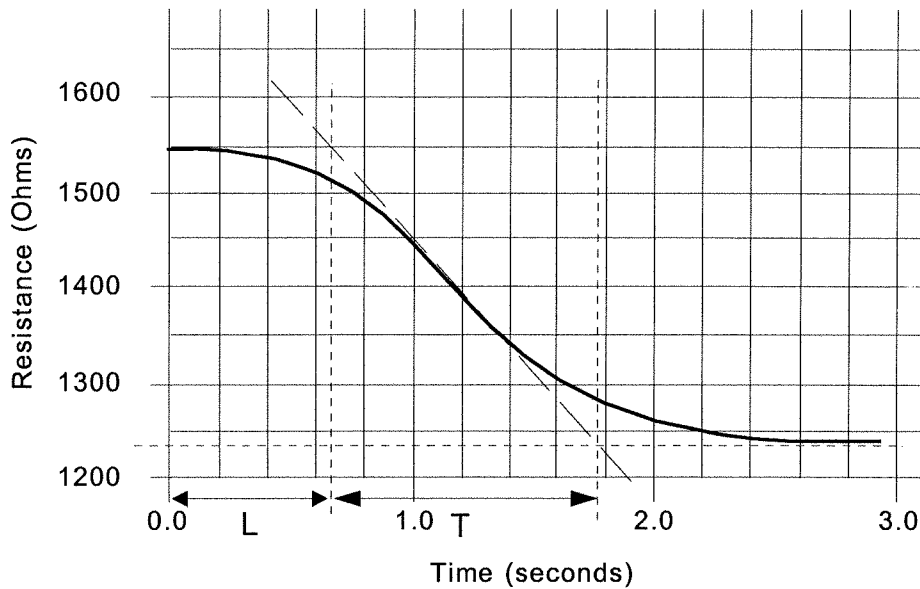

So we get $L = 0.65$ s and $T = 1.2$ s

Then,

$$N = \Delta C_p / T = 26.7 / 1.2 = 22.25, \quad R = L / T = 0.60 / 1.2 = 0.5$$

(a) Ziegler/Nichols: $K_p = 0.9 \Delta P / (NL) = 0.9(15) / (22.25)(0.6) = 1.01$
 $T_i = 3.33L = 3.33(0.6 \text{ s}) = 2 \text{ s}$

(b) Quarter Amplitude: $K_p = \Delta P [0.9 + R/12] / (NL) = 15 [0.9 + 0.5/12] / (22.25)(0.6)$
 $K_p = 1.05$
 $T_i = L(30 + R) / (9 + 20R) = 30.5(0.6 \text{ s}) / 19$
 $T_i = 0.96 \text{ s}$

